

***Solutions to
I.E. Irodov's
Problems in
General Physics***

Volume II

Waves . Optics . Modern Physics

Second Edition

ABHAY KUMAR SINGH

Director

Abhay's I.I.T. Physics Teaching Centre

Patna-6



CBS

CBS PUBLISHERS & DISTRIBUTORS

4596/1A, 11 DARYAGANJ, NEW DELHI - 110 002 (INDIA)

ISBN : 81-239-0486-X

First Edition : 1996

Reprint : 1997

Second Edition : 1998

Reprint : 2000

Reprint : 2002

Reprint : 2004

Copyright © Author & Publisher

All rights reserved. No part of this book may be reproduced or transmitted in any form or by any means, electronic or mechanical, including photocopying, recording, or any information storage and retrieval system without permission, in writing, from the publisher.

Published by S.K. Jain for CBS Publishers & Distributors,
4596/1A, 11 Darya Ganj, New Delhi - 110 002 (India).

Printed at :

J.S. Offset Printers, Delhi - 110 051

***In the memory of
Late Shri Arvind Kumar***

(Ex-Director, The Premier Institute, Patna)

The man who taught me how to teach.

FOREWORD

Science, in general, and physics, in particular, have evolved out of man's quest to know beyond unknowns. Matter, radiation and their mutual interactions are basically studied in physics. Essentially, this is an experimental science. By observing appropriate phenomena in nature one arrives at a set of rules which goes to establish some basic fundamental concepts. Entire physics rests on them. Mere knowledge of them is however not enough. Ability to apply them to real day-to-day problems is required. Prof. Irodov's book contains one such set of numerical exercises spread over a wide spectrum of physical disciplines. Some of the problems of the book long appeared to be notorious to pose serious challenges to students as well as to their teachers. This book by Prof. Singh on the solutions of problems of Irodov's book, at the outset, seems to remove the sense of awe which at one time prevailed. Traditionally a difficult exercise to solve continues to draw the attention of concerned persons over a sufficiently long time. Once a logical solution for it becomes available, the difficulties associated with its solutions are forgotten very soon. This statement is not only valid for the solutions of simple physical problems but also to various physical phenomena.

Nevertheless, Prof. Singh's attempt to write a book of this magnitude deserves an all out praise. His ways of solving problems are elegant, straight forward, simple and direct. By writing this book he has definitely contributed to the cause of physics education. A word of advice to its users is however necessary. The solution to a particular problem as given in this book is never to be consulted unless an all out effort in solving it independently has been already made. Only by such judicious uses of this book one would be able to reap better benefits out of it.

As a teacher who has taught physics and who has been in touch with physics curricula at I.I.T., Delhi for over thirty years, I earnestly feel that this book will certainly be of benefit to younger students in their formative years.

Dr. Dilip Kumar Roy
Professor of Physics
Indian Institute of Technology, Delhi
New Delhi-110016.

FOREWORD

A proper understanding of the physical laws and principles that govern nature require solutions of related problems which exemplify the principle in question and leads to a better grasp of the principles involved. It is only through experiments or through solutions of multifarious problem-oriented questions can a student master the intricacies and fall outs of a physical law. According to Ira M. Freeman, professor of physics of the state university of new Jersey at Rutgers and author of "physic--principles and Insights" -- "In certain situations mathematical formulation actually promotes intuitive understanding..... Sometimes a mathematical formulation is not feasible, so that ordinary language must take the place of mathematics in both roles. However, Mathematics is far more rigorous and its concepts more precise than those of language. Any science that is able to make extensive use of mathematical symbolism and procedures is justly called an exact science". I.E. Irodov's problems in General Physics fulfills such a need. This book originally published in Russia contains about 1900 problems on mechanics, thermodynamics, molecular physics, electrodynamics, waves and oscillations, optics, atomic and nuclear physics. The book has survived the test of class room for many years as is evident from its number of reprint editions, which have appeared since the first English edition of 1981, including an Indian Edition at affordable price for Indian students.

Abhay Kumar Singh's present book containing solutions to Dr. I.E. Irodov's Problems in General Physics is a welcome attempt to develop a student's problem solving skills. The book should be very useful for the students studying a general course in physics and also in developing their skills to answer questions normally encountered in national level entrance examinations conducted each year by various bodies for admissions to professional colleges in science and technology.

B.P. PAL
Professor of Physics
I.I.T., Delhi

Preface to the Second Edition

Perhaps nothing could be more gratifying for an author than seeing his 'brainchild' attain wide acclaim. Fortunately, it happens so with 'Solutions to I. E. Irodov's Problems in General Physics (Volume-II)' authored by me. Since inception, it showed signs of excellence amidst its 'peer-group', so much so that it fell victim to Piracy-syndrome. The reported onrush of spurious copies of this volume in the market accelerated the pace of our contemplation for this second edition. Taking advantage of this occasion the book has almost been completely vetted to cater to the needs of aspiring students.

My heart felt thanks are due to all those who have directly or indirectly engineered the cause of its existing status in the book-world.

Patna

June 1997

Abhay Kumar Singh

Preface

This is the second volume of my "Solutions to I.E. Irodov's Problems in General Physics." It contains solutions to the last three chapters of the problem book "Problems in General Physics". As in the first volume, in this second one also only standard methods have been used to solve the problems, befitting the standard of the problems solved.

Nothing succeeds like success, they say. From the way my earlier books have been received by physics loving people all over the country, I can only hope that my present attempt too will be appreciated and made use of at a large scale by the physics fraternity.

My special thanks are due to my teacher Dr. (Prof.) J. Thakur, Department of Physics, Patna University, who has been my source of energy and inspiration throughout the preparation of this book. I am also thankful to computer operator Mr. S. Shahab Ahmad and artist Rajeshwar Prasad of my institute (Abhay's I.I.T. Physics Teaching Centre, Mahendru, Patna-6) for their pains-taking efforts. I am also thankful to all my well-wishers, friends and family members for their emotional support.

Abhay Kumar Singh

Patna
July, 1996

CONTENTS

<i>Preface</i>	vii
--------------------------	-----

PART FOUR OSCILLATIONS AND WAVES

4.1 Mechanical Oscillations	1
4.2 Electric Oscillations	54
4.3 Elastic Waves. Acoustics	82
4.4 Electromagnetic Waves. Radiation	103

PART FIVE OPTICS

5.1 Photometry and Geometrical Optics	115
5.2 Interference of Light	149
5.3 Diffraction of Light	162
5.4 Polarization of Light	196
5.5 Dispersion and Absorption of Light	219
5.6 Optics of Moving Sources	229
5.7 Thermal Radiation. Quantum Nature of Light	238

PART SIX ATOMIC AND NUCLEAR PHYSICS

6.1 Scattering of Particles. Rutherford-Bohr Atom	259
6.2 Wave Properties of Particles. Schrödinger Equation	285
6.3 Properties of Atoms. Spectra	310
6.4 Molecules and Crystals	337
6.5 Radioactivity	360
6.6 Nuclear Reactions	372
6.7 Elementary Particles	387

OSCILLATIONS AND WAVES

4.1 MECHANICAL OSCILLATIONS

4.1 (a) Given, $x = a \cos \left(\omega t - \frac{\pi}{4} \right)$

So, $v_x = \dot{x} = -a \omega \sin \left(\omega t - \frac{\pi}{4} \right)$ and $w_x = \ddot{x} = -a \omega^2 \cos \left(\omega t - \frac{\pi}{4} \right)$ (1)

On-the-basis of obtained expressions plots $x(t)$, $v_x(t)$ and $w_x(t)$ can be drawn as shown in the answersheet, (of the problem book).

(b) From Eqn (1)

$$v_x = -a \omega \sin \left(\omega t - \frac{\pi}{4} \right) \quad \text{So, } v_x^2 = a^2 \omega^2 \sin^2 \left(\omega t - \frac{\pi}{4} \right) \quad (2)$$

But from the law $x = a \cos (\omega t - \pi/4)$, so, $x^2 = a^2 \cos^2 (\omega t - \pi/4)$

$$\text{or, } \cos^2 (\omega t - \pi/4) = x^2/a^2 \quad \text{or } \sin^2 (\omega t - \pi/4) = 1 - \frac{x^2}{a^2} \quad (3)$$

Using (3) in (2),

$$v_x^2 = a^2 \omega^2 \left(1 - \frac{x^2}{a^2} \right) \quad \text{or } v_x^2 = \omega^2 (a^2 - x^2) \quad (4)$$

Again from Eqn (4), $w_x = -a \omega^2 \cos (\omega t - \pi/4) = -\omega^2 x$

4.2 (a) From the motion law of the particle

$$x = a \sin^2 (\omega t - \pi/4) = \frac{a}{2} \left[1 - \cos \left(2 \omega t - \frac{\pi}{2} \right) \right]$$

$$\text{or, } x - \frac{a}{2} = -\frac{a}{2} \cos \left(2 \omega t - \frac{\pi}{2} \right) = -\frac{a}{2} \sin 2 \omega t = \frac{a}{2} \sin (2 \omega t + \pi)$$

$$\text{i.e. } x - \frac{a}{2} = \frac{a}{2} \sin (2 \omega t + \pi). \quad (1)$$

Now comparing this equation with the general equation of harmonic oscillations :

$$X = A \sin (\omega_0 t + \alpha)$$

Amplitude, $A = \frac{a}{2}$ and angular frequency, $\omega_0 = 2 \omega$.

Thus the period of one full oscillation, $T = \frac{2 \pi}{\omega_0} = \frac{\pi}{\omega}$

(b) Differentiating Eqn (1) w.r.t. time

$$v_x = a \omega \cos(2\omega t + \pi) \text{ or } v_x^2 = a^2 \omega^2 \cos^2(2\omega t + \pi) = a^2 \omega^2 [1 - \sin^2(2\omega t + \pi)] \quad (2)$$

$$\text{From Eqn (1)} \quad \left(x - \frac{a}{2}\right)^2 = \frac{a^2}{4} \sin^2(2\omega t + \pi)$$

$$\text{or, } 4 \frac{x^2}{a^2} + 1 - \frac{4x}{a} = \sin^2(2\omega t + \pi) \text{ or } 1 - \sin^2(2\omega t + \pi) = \frac{4x}{a} \left(1 - \frac{x}{a}\right) \quad (3)$$

$$\text{From Eqns (2) and (3), } v_x = a^2 \omega^2 \frac{4x}{a} \left(1 - \frac{x}{a}\right) = 4\omega^2 x(a-x)$$

Plot of $v_x(x)$ is as shown in the answersheet.

4.3 Let the general equation of S.H.M. be

$$x = a \cos(\omega t + \alpha) \quad (1)$$

$$\text{So, } v_x = -a\omega \sin(\omega t + \alpha) \quad (2)$$

Let us assume that at $t = 0$, $x = x_0$ and $v_x = v_{x_0}$.

Thus from Eqns (1) and (2) for $t = 0$, $x_0 = a \cos \alpha$, and $v_{x_0} = -a\omega \sin \alpha$

$$\text{Therefore } \tan \alpha = -\frac{v_{x_0}}{\omega x_0} \text{ and } a = \sqrt{x_0^2 + \left(\frac{v_{x_0}}{\omega}\right)^2} = 35.35 \text{ cm}$$

Under our assumption Eqns (1) and (2) give the sought x and v_x if

$$t = t = 2.40 \text{ s, } a = \sqrt{x_0^2 + \left(\frac{v_{x_0}}{\omega}\right)^2} \text{ and } \alpha = \tan^{-1} \left(-\frac{v_x}{\omega x_0}\right) = -\frac{\pi}{4}$$

Putting all the given numerical values, we get :

$$x = -29 \text{ cm and } v_x = -81 \text{ cm/s}$$

4.4 From the Eqn, $v_x^2 = \omega^2 (a^2 - x^2)$ (see Eqn. 4 of 4.1)

$$v_1^2 = \omega^2 (a^2 - x_1^2) \text{ and } v_2^2 = \omega^2 (a^2 - x_2^2)$$

Solving these Eqns simultaneously, we get

$$\omega = \sqrt{(v_1^2 - v_2^2) / (x_2^2 - x_1^2)}, \quad a = \sqrt{(v_1 x_2^2 - v_2^2 x_1^2) / (v_1^2 - v_2^2)}$$

4.5 (a) When a particle starts from an extreme position, it is useful to write the motion law as

$$x = a \cos \omega t \quad (1)$$

(However x is the displacement from the equilibrium position)

It t_1 be the time to cover the distance $a/2$ then from (1)

$$a - \frac{a}{2} = \frac{a}{2} = a \cos \omega t_1 \text{ or } \cos \omega t_1 = \frac{1}{2} = \cos \frac{\pi}{3} \text{ (as } t_1 < T/4)$$

$$\text{Thus } t_1 = \frac{\pi}{3\omega} = \frac{\pi}{3(2\pi/T)} = \frac{T}{6}$$

As $x = a \cos \omega t$, so, $v_x = -a \omega \sin \omega t$

Thus $v = |v_x| = -v_x = a \omega \sin \omega t$, for $t \leq t_1 = T/6$

Hence sought mean velocity

$$\langle v \rangle = \frac{\int v dt}{\int dt} = \frac{\int_0^{T/6} a (2\pi/T) \sin \omega t dt}{T/6} = \frac{3a}{T} = 0.5 \text{ m/s}$$

(b) In this case, it is easier to write the motion law in the form :

$$x = a \sin \omega t \quad (2)$$

If t_2 be the time to cover the distance $a/2$, then from Eqn (2)

$$a/2 = a \sin \frac{2\pi}{T} t_2 \quad \text{or} \quad \sin \frac{2\pi}{T} t_2 = \frac{1}{2} = \sin \frac{\pi}{6} \quad (\text{as } t_2 < T/4)$$

Thus
$$\frac{2\pi}{T} t_2 = \frac{\pi}{6} \quad \text{or, } t_2 = \frac{T}{12}$$

Differentiating Eqn (2) w.r.t time, we get

$$v_x = a \omega \cos \omega t = a \frac{2\pi}{T} \cos \frac{2\pi}{T} t$$

So,
$$v = |v_x| = a \frac{2\pi}{T} \cos \frac{2\pi}{T} t$$
, for $t \leq t_2 = T/12$

Hence the sought mean velocity

$$\langle v \rangle = \frac{\int v dt}{\int dt} = \frac{1}{(T/12)} \int_0^{T/12} a \frac{2\pi}{T} \cos \frac{2\pi}{T} t dt = \frac{6a}{T} = 1 \text{ m/s}$$

4.6 (a) As $x = a \sin \omega t$ so, $v_x = a \omega \cos \omega t$

$$\frac{3}{8}T$$

$$\text{Thus } \langle v_x \rangle = \frac{\int v_x dt}{\int dt} = \frac{\int_0^{\frac{3}{8}T} a \omega \cos (2\pi/T) t dt}{\frac{3}{8}T} = \frac{2\sqrt{2} a \omega}{3\pi} \left(\text{using } T = \frac{2\pi}{\omega} \right)$$

(b) In accordance with the problem

$$\vec{v} = v_x \vec{i}, \quad \text{so, } |\langle \vec{v} \rangle| = |\langle v_x \rangle|$$

$$\text{Hence, using part (a), } |\langle \vec{v} \rangle| = \left| \frac{2\sqrt{2} a \omega}{3\pi} \right| = \frac{2\sqrt{2} a \omega}{3\pi}$$

(c) We have got, $v_x = a \omega \cos \omega t$

$$\left. \begin{aligned} \text{So, } v = |v_x| &= a \omega \cos \omega t, \quad \text{for } t \leq T/4 \\ &= -a \omega \cos \omega t, \quad \text{for } T/4 \leq t \leq \frac{3}{8}T \end{aligned} \right\}$$

Hence,
$$\langle v \rangle = \frac{\int_0^{T/4} a \omega \cos \omega t dt + \int_{T/4}^{3T/8} -a \omega \cos \omega t dt}{\int_0^{T/4} dt} = \frac{3T/8}{3T/8}$$

Using $\omega = 2\pi/T$, and on evaluating the integral we get

$$\langle v \rangle = \frac{2(4 - \sqrt{2})a\omega}{3\pi}$$

4.7 From the motion law, $x = a \cos \omega t$, it is obvious that the time taken to cover the distance equal to the amplitude (a), starting from extreme position equals $T/4$.

Now one can write

$$t = n \frac{T}{4} + t_0, \quad \left(\text{where } t_0 < \frac{T}{4} \text{ and } n = 0, 1, 2, \dots \right)$$

As the particle moves according to the law, $x = a \cos \omega t$,

so at $n = 1, 3, 5 \dots$ or for odd n values it passes through the mean position and for even numbers of n it comes to an extreme position (if $t_0 = 0$).

Case (1) when n is an odd number :

In this case, from the equation

$x = \pm a \sin \omega t$, if the t is counted from $nT/4$ and the distance covered in the time interval

$$\text{to becomes, } s_1 = a \sin \omega t_0 = a \sin \omega \left(t - n \frac{T}{4} \right) = a \sin \left(\omega t - \frac{n\pi}{2} \right)$$

Thus the sought distance covered for odd n is

$$s = na + s_1 = na + a \sin \left(\omega t - \frac{n\pi}{2} \right) = a \left[n + \sin \left(\omega t - \frac{n\pi}{2} \right) \right]$$

Case (2), when n is even, In this case from the equation

$x = a \cos \omega t$, the distance covered (s_2) in the interval t_0 , is given by

$$a - s_2 = a \cos \omega t_0 = a \cos \omega \left(t - n \frac{T}{4} \right) = a \cos \left(\omega t - n \frac{\pi}{2} \right)$$

$$\text{or, } s_2 = a \left[1 - \cos \left(\omega t - \frac{n\pi}{2} \right) \right]$$

Hence the sought distance for n is even

$$s = na + s_2 = na + a \left[1 - \cos \left(\omega t - \frac{n\pi}{2} \right) \right] = a \left[n + 1 - \cos \left(\omega t - \frac{n\pi}{2} \right) \right]$$

In general

$$s = \begin{cases} a \left[n + 1 - \cos \left(\omega t - \frac{n\pi}{2} \right) \right], & n \text{ is even} \\ a \left[n + \sin \left(\omega t - \frac{n\pi}{2} \right) \right], & n \text{ is odd} \end{cases}$$

4.8 Obviously the motion law is of the form, $x = a \sin \omega t$. and $v_x = \omega a \cos \omega t$.

Comparing $v_x = \omega a \cos \omega t$ with $v_x = 35 \cos \pi t$, we get

$$\omega = \pi, a = \frac{35}{\pi}, \text{ thus } T = \frac{2\pi}{\omega} = 2 \text{ and } T/4 = 0.5 \text{ s}$$

Now we can write

$$t = 2.8 \text{ s} = 5 \times \frac{T}{4} + 0.3 \left(\text{where } \frac{T}{4} = 0.5 \text{ s} \right)$$

As $n = 5$ is odd, like (4.7), we have to basically find the distance covered by the particle starting from the extreme position in the time interval 0.3 s.

Thus from the Eqn.

$$x = a \cos \omega t = \frac{35}{\pi} \cos \pi (0.3)$$

$$\frac{35}{\pi} - s_1 = \frac{35}{\pi} \cos \pi (0.3) \quad \text{or } s_1 = \frac{35}{\pi} \{1 - \cos 0.3 \pi\}$$

Hence the sought distance

$$\begin{aligned} s &= 5 \times \frac{35}{\pi} + \frac{35}{\pi} \{1 - \cos 0.3 \pi\} \\ &= \frac{35}{\pi} \{6 - \cos 0.3 \pi\} = \frac{35}{22} \times 7 (6 - \cos 54^\circ) = 60 \text{ cm} \end{aligned}$$

4.9 As the motion is periodic the particle repeatedly passes through any given region in the range $-a \leq x \leq a$. The probability that it lies in the range $(x, x + dx)$ is defined as the fraction $\frac{\Delta t}{t}$ (as $t \rightarrow \infty$) where Δt is the time that the particle lies in the range $(x, x + dx)$ out of the total time t . Because of periodicity this is

$$dP = \frac{dP}{dx} dx = \frac{dt}{T} = \frac{2 dx}{v T}$$

where the factor 2 is needed to take account of the fact that the particle is in the range $(x, x + dx)$ during both up and down phases of its motion. Now in a harmonic oscillator.

$$v = \dot{x} = \omega a \cos \omega t = \omega \sqrt{a^2 - x^2}$$

Thus since $\omega T = 2\pi$ (T is the time period)

$$\text{We get} \quad dP = \frac{dP}{dx} dx = \frac{1}{\pi} \frac{dx}{\sqrt{a^2 - x^2}}$$

$$\text{Note that} \quad \int_{-a}^{+a} \frac{dP}{dx} dx = 1$$

$$\text{so} \quad \frac{dP}{dx} = \frac{1}{\pi} \frac{1}{\sqrt{a^2 - x^2}} \text{ is properly normalized.}$$

- 4.10 (a) We take a graph paper and choose an axis (X -axis) and an origin. Draw a vector of magnitude 3 inclined at an angle $\frac{\pi}{3}$ with the X -axis. Draw another vector of magnitude 8 inclined at an angle $-\frac{\pi}{3}$ (Since $\sin(\omega t + \pi/6) = \cos(\omega t - \pi/3)$) with the X -axis. The magnitude of the resultant of both these vectors (drawn from the origin) obtained using parallelogram law is the resultant, amplitude.

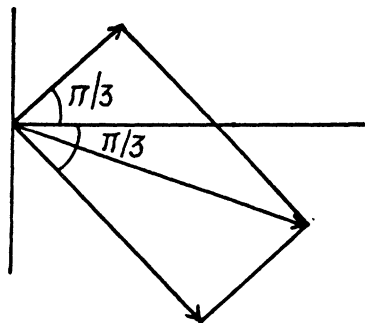

$$\text{Clearly} \quad R^2 = 3^2 + 8^2 + 2 \cdot 3 \cdot 8 \cdot \cos \frac{2\pi}{3} = 9 + 64 - 48 \times \frac{1}{2}$$

$$= 73 - 24 = 49$$

$$\text{Thus} \quad R = 7 \text{ units}$$

- (b) One can follow the same graphical method here but the result can be obtained more quickly by breaking into sines and cosines and adding :

$$\text{Resultant} \quad x = \left(3 + \frac{5}{\sqrt{2}}\right) \cos \omega t + \left(6 - \frac{5}{\sqrt{2}}\right) \sin \omega t$$

$$= A \cos(\omega t + \alpha)$$

$$\text{Then} \quad A^2 = \left(3 + \frac{5}{\sqrt{2}}\right)^2 + \left(6 - \frac{5}{\sqrt{2}}\right)^2 = 9 + 25 + \frac{30 - 60}{\sqrt{2}} + 36$$

$$= 70 - 15\sqrt{2} = 70 - 21.2$$

$$\text{So,} \quad A = 6.985 \approx 7 \text{ units}$$

Note- In using graphical method convert all oscillations to either sines or cosines but do not use both.

- 4.11 Given, $x_1 = a \cos \omega t$ and $x_2 = a \cos 2\omega t$

so, the net displacement,

$$x = x_1 + x_2 = a \{ \cos \omega t + \cos 2\omega t \} = a \{ \cos \omega t + 2 \cos^2 \omega t - 1 \}$$

$$\text{and} \quad v_x = \dot{x} = a \{ -\omega \sin \omega t - 4\omega \cos \omega t \sin \omega t \}$$

For \dot{x} to be maximum,

$$\ddot{x} = a \omega^2 \cos \omega t - 4a \omega^2 \cos^2 \omega t + 4a \omega^2 \sin^2 \omega t = 0$$

or, $8 \cos^2 \omega t + \cos \omega t - 4 = 0$, which is a quadratic equation for $\cos \omega t$.

Solving for acceptable value

$$\cos \omega t = 0.644$$

thus

$$\sin \omega t = 0.765$$

and

$$v_{\max} = |v_{x_{\max}}| = +a\omega [0.765 + 4 \times 0.765 \times 0.644] = +2.73 a \omega$$

4.12 We write :

$$a \cos 2.1 t \cos 50.0 t = \frac{a}{2} \{ \cos 52.1 t + \cos 47.9 t \}$$

Thus the angular frequencies of constituent oscillations are

$$52.1 \text{ s}^{-1} \text{ and } 47.9 \text{ s}^{-1}$$

To get the beat period note that the variable amplitude $a \cos 2.1 t$ becomes maximum (positive or negative), when

$$2.1 t = n \pi$$

Thus the interval between two maxima is

$$\frac{\pi}{2.1} = 1.5 \text{ s nearly.}$$

4.13 If the frequency of A with respect to K' is ν_0 and K' oscillates with frequency $\bar{\nu}$ with respect to K , the beat frequency of the point A in the K -frame will be ν when

$$\bar{\nu} = \nu_0 \pm \nu$$

In the present case $\bar{\nu} = 20$ or 24 . This means

$$\nu_0 = 22. \text{ \& } \nu = 2$$

Thus beats of $2\nu = 4$ will be heard when $\bar{\nu} = 26$ or 18 .

4.14 (a) From the Eqn : $x = a \sin \omega t$

$$\sin^2 \omega t = x^2/a^2 \quad \text{or} \quad \cos^2 \omega t = 1 - \frac{x^2}{a^2} \quad (1)$$

And from the equation : $y = b \cos \omega t$

$$\cos^2 \omega t = y^2/b^2 \quad (2)$$

From Eqns (1) and (2), we get :

$$1 - \frac{x^2}{a^2} = \frac{y^2}{b^2} \quad \text{or} \quad \frac{x^2}{a^2} + \frac{y^2}{b^2} = 1$$

which is the standard equation of the ellipse shown in the figure.

we observe that,

at $t = 0, x = 0$ and $y = b$

and at $t = \frac{\pi}{2\omega}, x = +a$ and $y = 0$

Thus we observe that at $t = 0$, the point is at point 1 (Fig.) and at the following moments, the co-ordinate y diminishes and x becomes positive. Consequently the motion is clockwise.

(b) As $x = a \sin \omega t$ and $y = b \cos \omega t$

So we may write $\vec{r} = a \sin \omega t \vec{i} + b \cos \omega t \vec{j}$

Thus $\dot{\vec{r}} = \vec{v} = -\omega^2 \vec{r}$

4.15 (a) From the Eqn. : $x = a \sin \omega t$, we have

$$\cos \omega t = \sqrt{1 - (x^2/a^2)}$$

and from the Eqn. : $y = a \sin 2 \omega t$

$$y = 2 a \sin \omega t \cos \omega t = 2 x \sqrt{1 - (x^2/a^2)} \quad \text{or} \quad y^2 = 4 x^2 \left(1 - \frac{x^2}{a^2}\right)$$

(b) From the Eqn. : $x = a \sin \omega t$;

$$\sin^2 \omega t = x^2/a^2$$

From $y = a \cos 2 \omega t$

$$y = a (1 - 2 \sin^2 \omega t) = a \left(1 - 2 \frac{x^2}{a^2}\right)$$

For the plots see the plots of answersheet of the problem book.

4.16 As $U(x) = U_0(1 - \cos ax)$

$$\text{So,} \quad F_x = -\frac{dU}{dx} = -U_0 a \sin ax \quad (1)$$

or, $F_x = -U_0 a \sin ax$ (because for small angle of oscillations $\sin ax \approx ax$)

$$\text{or,} \quad F_x = -U_0 a^2 x \quad (1)$$

But we know $F_x = -m \omega_0^2 x$, for small oscillation

$$\text{Thus} \quad \omega_0^2 = \frac{U_0 a^2}{m} \quad \text{or} \quad \omega_0 = a \sqrt{\frac{U_0}{m}}$$

Hence the sought time period

$$T = \frac{2\pi}{\omega_0} = \frac{2\pi}{a} \sqrt{\frac{m}{U_0}} = 2\pi \sqrt{\frac{m}{a^2 U_0}}$$

4.17 If $U(x) = \frac{a}{x^2} - \frac{b}{x}$

then the equilibrium position is $x = x_0$ when $U'(x_0) = 0$

$$\text{or} \quad -\frac{2a}{x_0^3} + \frac{b}{x_0^2} = 0 \Rightarrow x_0 = \frac{2a}{b}$$

Now write : $x = x_0 + y$

$$\text{Then} \quad U(x) = \frac{a}{x_0^2} - \frac{b}{x_0} + (x - x_0) U'(x_0) + \frac{1}{2} (x - x_0)^2 U''(x_0)$$

$$\text{But} \quad U''(x_0) = \frac{6a}{x_0^4} - \frac{2b}{x_0^3} = (2a/b)^{-3} (3b - 2b) = b^4/8a^3$$

$$\text{So finally :} \quad U(x) = U(x_0) + \frac{1}{2} \left(\frac{b^4}{8a^3} \right) y^2 + \dots$$

We neglect remaining terms for small oscillations and compare with the P.E. for a harmonic oscillator :

$$\frac{1}{2} m \omega^2 y^2 = \frac{1}{2} \left(\frac{b^4}{8 a^3} \right) y^2, \text{ so } \omega = \frac{b^2}{\sqrt{8 a^3 m}}$$

Thus
$$T = 2\pi \frac{\sqrt{8 m a^3}}{b^2}$$

Note : Equilibrium position is generally a minimum of the potential energy. Then $U'(x_0) = 0$, $U''(x_0) > 0$. The equilibrium position can in principle be a maximum but then $U''(x_0) < 0$ and the frequency of oscillations about this equilibrium position will be imaginary.

The answer given in the book is incorrect both numerically and dimensionally.

- 4.18 Let us locate and depict the forces acting on the ball at the position when it is at a distance x down from the undeformed position of the string.

At this position, the unbalanced downward force on the ball

$$= m g - 2 F \sin \theta$$

By Newton's law, $m \ddot{x} = m g - 2 F \sin \theta$

$$= m g - 2 F \theta \text{ (when } \theta \text{ is small)}$$

$$= m g - 2 F \frac{x}{l/2} = m g - \frac{4 F}{l} x$$

Thus
$$\ddot{x} = g - \frac{4 F}{m l} x = -\frac{4 F}{m l} \left(x - \frac{m g l}{4 F} \right)$$

putting $x' = x - \frac{m g l}{4 F}$, we get

$$\ddot{x}' = -\frac{4 F}{m l} x'$$

Thus
$$T = \pi \sqrt{\frac{m l}{F}} = 0.2 \text{ s}$$

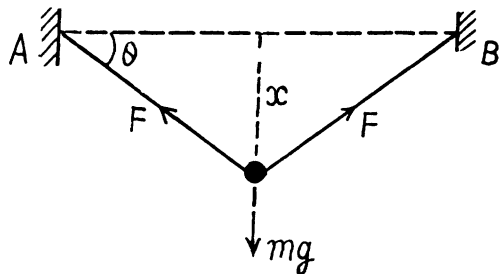

- 4.19 Let us depict the forces acting on the oscillating ball at an arbitrary angular position θ . (Fig.), relative to equilibrium position where F_B is the force of buoyancy. For the ball from the equation :

$N_Z = I \beta_Z$, (where we have taken the positive sense of Z axis in the direction of angular velocity i.e. $\dot{\theta}$ of the ball and passes through the point of suspension of the pendulum O), we get :

$$-m g l \sin \theta + F_B l \sin \theta = m l^2 \ddot{\theta}$$

Using $m = \frac{4}{3} \pi r^3 \sigma$, $F_B = \frac{4}{3} \pi r^3 \rho$ and $\sin \theta \approx \theta$ for small θ , in Eqn (1), we get :

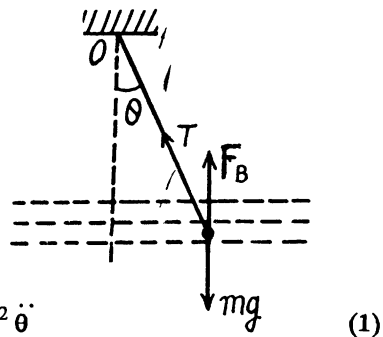

$$\ddot{\theta} = -\frac{g}{l} \left(1 - \frac{\rho}{\sigma}\right) \theta$$

Thus the sought time period

$$T = 2\pi \frac{1}{\sqrt{\frac{g}{l} \left(1 - \frac{\rho}{\sigma}\right)}} = 2\pi \sqrt{\frac{l/g}{1 - \frac{1}{\eta}}}$$

Hence
$$T = 2\pi \sqrt{\frac{\eta l}{g(\eta - 1)}} = 1.1s$$

4.20 Obviously for small β the ball execute part of S.H.M. Due to the perfectly elastic collision the velocity of ball simply reversed. As the ball is in S.H.M. ($|\theta| < \alpha$ on the left) its motion law in differential form can be written as

$$\ddot{\theta} = -\frac{g}{l} \theta = -\omega_0^2 \theta \quad (1)$$

If we assume that the ball is released from the extreme position, $\theta = \beta$ at $t = 0$, the solution of differential equation would be taken in the form

$$\theta = \beta \cos \omega_0 t = \beta \cos \sqrt{\frac{g}{l}} t \quad (2)$$

If t' be the time taken by the ball to go from the extreme position $\theta = \beta$ to the wall i.e. $\theta = -\alpha$, then Eqn. (2) can be rewritten as

$$-\alpha = \beta \cos \sqrt{\frac{g}{l}} t'$$

or
$$t' = \sqrt{\frac{l}{g}} \cos^{-1} \left(-\frac{\alpha}{\beta} \right) = \sqrt{\frac{l}{g}} \left(\pi - \cos^{-1} \frac{\alpha}{\beta} \right)$$

Thus the sought time $T = 2t' = 2\sqrt{\frac{l}{g}} \left(\pi - \cos^{-1} \frac{\alpha}{\beta} \right)$

$$= 2\sqrt{\frac{l}{g}} \left(\frac{\pi}{2} + \sin^{-1} \frac{\alpha}{\beta} \right), \quad [\text{because } \sin^{-1} x + \cos^{-1} x = \pi/2]$$

4.21 Let the downward acceleration of the elevator car has continued for time t' , then the sought time

$$t = \sqrt{\frac{2h}{w}} + t', \text{ where obviously } \sqrt{\frac{2h}{w}} \text{ is the time of upward acceleration of the elevator.}$$

One should note that if the point of suspension of a mathematical pendulum moves with an acceleration \vec{w} , then the time period of the pendulum becomes

$$2\pi \sqrt{\frac{l}{|\vec{g} - \vec{w}|}} \quad (\text{see 4.30})$$

In this problem the time period of the pendulum while it is moving upward with acceleration w becomes

$2\pi \sqrt{\frac{l}{g+w}}$ and its time period while the elevator moves downward with the same magnitude of acceleration becomes

$$2\pi \sqrt{\frac{l}{g-w}}$$

As the time of upward acceleration equals $\sqrt{\frac{2h}{w}}$, the total number of oscillations during this time equals

$$\frac{\sqrt{2h/w}}{2\pi \sqrt{l/(g+w)}}$$

Thus the indicated time = $\frac{\sqrt{2h/w}}{2\pi \sqrt{l/(g+w)}} \cdot 2\pi \sqrt{l/g} = \sqrt{2h/w} \sqrt{(g+w)/g}$

Similarly the indicated time for the time interval t'

$$= \frac{t'}{2\pi \sqrt{l/(g-w)}} 2\pi \sqrt{l/g} = t' \sqrt{(g-w)/g}$$

we demand that

$$\sqrt{2h/w} \sqrt{(g+w)/g} + t' \sqrt{(g-w)/g} = \sqrt{2h/w} + t'$$

or,

$$t' = \sqrt{2h/w} \frac{\sqrt{g+w} - \sqrt{g}}{\sqrt{g} - \sqrt{g-w}}$$

Hence the sought time

$$\begin{aligned} t &= \sqrt{\frac{2h}{w}} + t' = \sqrt{\frac{2h}{w}} \frac{\sqrt{g+w} - \sqrt{g-w}}{\sqrt{g} - \sqrt{g-w}} \\ &= \sqrt{\frac{2h}{w}} \frac{\sqrt{1+\beta} - \sqrt{1-\beta}}{1 - \sqrt{1-\beta}}, \text{ where } \beta = w/g \end{aligned}$$

- 4.22** If the hydrometer were in equilibrium or floating, its weight will be balanced by the buoyancy force acting on it by the fluid. During its small oscillation, let us locate the hydrometer when it is at a vertically downward distance x from its equilibrium position. Obviously the net unbalanced force on the hydrometer is the excess buoyancy force directed upward and equals $\pi r^2 x \rho g$. Hence for the hydrometer.

$$m \ddot{x} = -\pi r^2 \rho g x$$

or,

$$\ddot{x} = -\frac{\pi r^2 \rho g}{m} x$$

Hence the sought time period

$$T = 2\pi \sqrt{\frac{m}{\pi r^2 \rho g}} = 2.5 \text{ s.}$$

- 4.23 At first let us calculate the stiffness κ_1 and κ_2 of both the parts of the spring. If we subject the original spring of stiffness κ having the natural length l_0 (say), under the deforming forces $F - F$ (say) to elongate the spring by the amount x , then

$$F = \kappa x \quad (1)$$

Therefore the elongation per unit length of the spring is x/l_0 . Now let us subject one of the parts of the spring of natural length ηl_0 under the same deforming forces $F - F$. Then the elongation of the spring will be

$$\frac{x}{l_0} \eta l_0 = \eta x$$

$$F = \kappa_1 (\eta x) \quad (2)$$

Thus

Hence from Eqns (1) and (2)

$$\kappa = \eta \kappa_1 \text{ or } \kappa_1 = \kappa/\eta \quad (3)$$

Similarly

$$\kappa_2 = \frac{\kappa}{1 - \eta}$$

The position of the block m when both the parts of the spring are non-deformed, is its equilibrium position O . Let us displace the block m towards right or in positive x axis by the small distance x . Let us depict the forces acting on the block when it is at a distance x from its equilibrium position (Fig.). From the second law of motion in projection form i.e.

$$F_x = m w_x$$

$$-\kappa_1 x - \kappa_2 x = m \ddot{x}$$

$$\text{or, } -\left(\frac{\kappa}{\eta} + \frac{\kappa}{1 - \eta}\right)x = m \ddot{x}$$

$$\text{Thus } \ddot{x} = -\frac{\kappa}{m \eta (1 - \eta)} x$$

Hence the sought time period

$$T = 2\pi \sqrt{\eta(1 - \eta)m/\kappa} = 0.13 \text{ s}$$

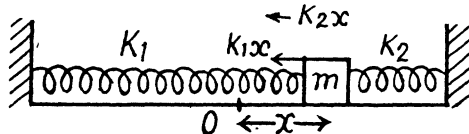

- 4.24 Similar to the Soln of 4.23, the net unbalanced force on the block m when it is at a small horizontal distance x from the equilibrium position becomes $(\kappa_1 + \kappa_2)x$.

From $F_x = m w_x$ for the block :

$$-(\kappa_1 + \kappa_2)x = m \ddot{x}$$

Thus

$$\ddot{x} = -\left(\frac{\kappa_1 + \kappa_2}{m}\right)x$$

Hence the sought time period $T = 2\pi \sqrt{\frac{m}{\kappa_1 + \kappa_2}}$

Alternate : Let us set the block m in motion to perform small oscillation. Let us locate the block when it is at a distance x from its equilibrium position.

As the spring force is restoring conservative force and deformation of both the springs are same, so from the conservation of mechanical energy of oscillation of the spring-block system :

$$\frac{1}{2} m \left(\frac{dx}{dt} \right)^2 + \frac{1}{2} \kappa_1 x^2 + \frac{1}{2} \kappa_2 x^2 = \text{Constant}$$

Differentiating with respect to time

$$\frac{1}{2} m 2 \dot{x} \ddot{x} + \frac{1}{2} (\kappa_1 + \kappa_2) 2 x \dot{x} = 0$$

or,
$$\ddot{x} = - \frac{(\kappa_1 + \kappa_2)}{m} x$$

Hence the sought time period $T = 2\pi \sqrt{\frac{m}{\kappa_1 + \kappa_2}}$

4.25 During the vertical oscillation let us locate the block at a vertical down distance x from its equilibrium position. At this moment if x_1 and x_2 are the additional or further elongation of the upper & lower springs relative to the equilibrium position, then the net unbalanced force on the block will be $\kappa_2 x_2$ directed in upward direction. Hence

$$-\kappa_2 x_2 = m \ddot{x} \quad (1)$$

We also have

$$x = x_1 + x_2 \quad (2)$$

As the springs are massless and initially the net force on the spring is also zero so for the spring

$$\kappa_1 x_1 = \kappa_2 x_2 \quad (3)$$

Solving the Eqns (1), (2) and (3) simultaneously, we get

$$-\frac{\kappa_1 \kappa_2}{\kappa_1 + \kappa_2} x = m \ddot{x}$$

Thus
$$\ddot{x} = - \frac{(\kappa_1 \kappa_2 / \kappa_1 + \kappa_2)}{m} x$$

Hence the sought time period $T = 2\pi \sqrt{m \frac{(\kappa_1 \kappa_2)}{\kappa_1 \kappa_2}}$

4.26 The force F , acting on the weight deflected from the position of equilibrium is $2 T_0 \sin \theta$.

Since the angle θ is small, the net restoring force, $F = 2 T_0 \frac{x}{l}$

or, $F = kx$, where $k = \frac{2 T_0}{l}$

So, by using the formula,

$$\omega_0 = \sqrt{\frac{k}{m}}, \quad \omega_0 = \sqrt{\frac{2 T_0}{m l}}$$

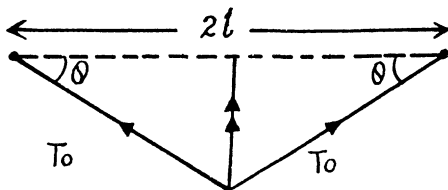

4.27 If the mercury rises in the left arm by x it must fall by a slanting length equal to x in the other arm. Total pressure difference in the two arms will then be

$$\rho g x + \rho g x \cos \theta = \rho g x (1 + \cos \theta)$$

This will give rise to a restoring force

$$-\rho g S x (1 + \cos \theta)$$

This must equal mass times acceleration which can be obtained from work energy principle.

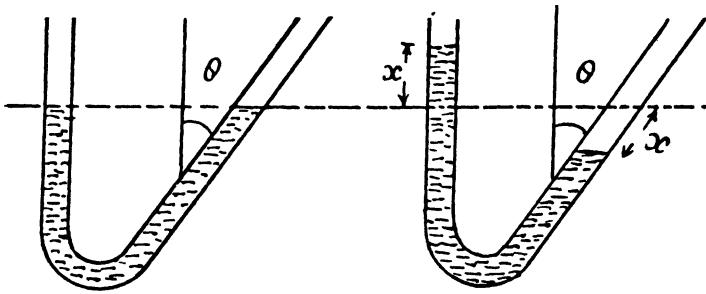

The K.E. of the mercury in the tube is clearly : $\frac{1}{2} m \dot{x}^2$

So mass times acceleration must be : $m \ddot{x}$

Hence $m \ddot{x} + \rho g S (1 + \cos \theta) x = 0$

This is S.H.M. with a time period

$$T = 2\pi \sqrt{\frac{m}{\rho g S (1 + \cos \theta)}}$$

- 4.28 In the equilibrium position the C.M. of the rod lies midway between the two rotating wheels. Let us displace the rod horizontally by some small distance and then release it. Let us depict the forces acting on the rod when its C.M. is at distance x from its equilibrium position (Fig.). Since there is no net vertical force acting on the rod, Newton's second law gives :

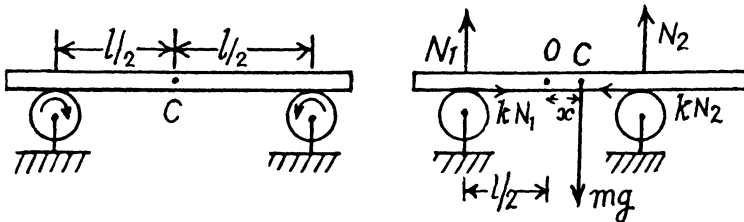

$$N_1 + N_2 = mg \quad (1)$$

For the translational motion of the rod from the Eqn. : $F_x = m w_{cx}$

$$kN_1 - kN_2 = m \ddot{x} \quad (2)$$

As the rod experiences no net torque about an axis perpendicular to the plane of the Fig. through the C.M. of the rod.

$$N_1 \left(\frac{l+x}{2} \right) = N_2 \left(\frac{l-x}{2} \right) \quad (3)$$

Solving Eqns. (1), (2) and (3) simultaneously we get

$$\ddot{x} = -k \frac{2g}{l} x$$

Hence the sought time period

$$T = 2\pi \sqrt{\frac{l}{2kg}} = \pi \sqrt{\frac{2l}{kg}} = 1.5 \text{ s}$$

- 4.29 (a) The only force acting on the ball is the gravitational force \vec{F} , of magnitude $\gamma \frac{4}{3} \pi \rho m r$, where γ is the gravitational constant ρ , the density of the Earth and r is the distance of the body from the centre of the Earth.

But, $g = \gamma \frac{4\pi}{3} \rho R$, so the expression for \vec{F} can be written as,

$\vec{F} = -m g \frac{\vec{r}}{R}$, here R is the radius of the Earth and the equation of motion in projection

form has the form, or, $m \ddot{x} + \frac{m g}{R} x = 0$

- (b) The equation, obtained above has the form of an equation of S.H.M. having the time period,

$$T = 2\pi \sqrt{\frac{R}{g}},$$

Hence the body will reach the other end of the shaft in the time,

$$t = \frac{T}{2} = \pi \sqrt{\frac{R}{g}} = 42 \text{ min.}$$

- (c) From the conditions of S.H.M., the speed of the body at the centre of the Earth will be maximum, having the magnitude,

$$v = R \omega = R \sqrt{g/R} = \sqrt{gR} = 7.9 \text{ km/s.}$$

- 4.30 In the frame of point of suspension the mathematical pendulum of mass m (say) will oscillate. In this frame, the body m will experience the inertial force $m(-\vec{w})$ in addition to the real forces during its oscillations. Therefore in equilibrium position m is deviated by some angle α . In equilibrium position

$$T_0 \cos \alpha = m g + m w \cos (\pi - \beta) \quad \text{and} \quad T_0 \sin \alpha = m w \sin (\pi - \beta)$$

So, from these two Eqns

$$\left. \begin{aligned} \tan \alpha &= \frac{g - w \cos \beta}{w \sin \beta} \\ \text{and } \cos \alpha &= \sqrt{\frac{m^2 w^2 \sin^2 \beta + (m g - m w \cos \beta)^2}{m g - m w \cos \beta}} \end{aligned} \right\} \quad (1)$$

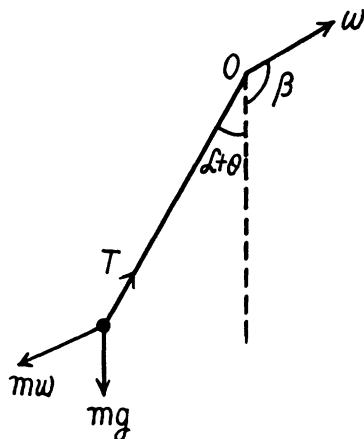
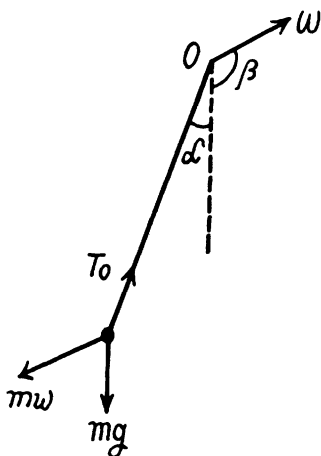

Let us displace the bob m from its equilibrium position by some small angle and then release it. Now locate the ball at an angular position $(\alpha + \theta)$ from vertical as shown in the figure.

From the Eqn. :

$$N_{0z} = l \beta_z$$

$$-m g l \sin(\alpha + \theta) - m w \cos(\pi - \beta) l \sin(\alpha + \theta) + m w \sin(\pi - \beta) l \cos(\alpha + \theta) = m l^2 \ddot{\theta}$$

$$\text{or, } -g(\sin \alpha \cos \theta + \cos \alpha \sin \theta) - w \cos(\pi - \beta)(\sin \alpha \cos \theta + \cos \alpha \sin \theta) + w \sin \beta (\cos \alpha - \sin \alpha \theta) \\ (\cos \alpha \cos \theta - \sin \alpha \sin \theta) \\ = l \ddot{\theta}$$

But for small

$$\theta, \sin \theta \approx \theta \cos \theta \approx 1$$

So,

$$-g(\sin \alpha + \cos \alpha \theta) - w \cos(\pi - \beta)(\sin \alpha + \cos \alpha \theta) + w \sin \beta (\cos \alpha - \sin \alpha \theta) \\ = l \ddot{\theta}$$

$$\text{or, } (\tan \alpha + \theta)(w \cos \beta - g) + w \sin \beta (1 - \tan \alpha \theta) = \frac{l}{\cos \alpha} \ddot{\theta} \quad (2)$$

Solving Eqns (1) and (2) simultaneously we get

$$-(g^2 - 2wg \cos \beta + w^2) \theta = l \sqrt{g^2 + w^2 - 2wg \cos \beta} \ddot{\theta}$$

Thus

$$\ddot{\theta} = -\frac{|\vec{g} - \vec{w}|}{l} \theta$$

$$\text{Hence the sought time period } T = \frac{2\pi}{\omega_0} = 2\pi \sqrt{\frac{l}{|\vec{g} - \vec{w}|}}$$

- 4.31 Obviously the sleeve performs small oscillations in the frame of rotating rod. In the rod's frame let us depict the forces acting on the sleeve along the length of the rod while the sleeve is at a small distance x towards right from its equilibrium position. The free body diagram of block does not contain Coriolis force, because it is perpendicular to the length of the rod. From $F_x = m w_x$ for the sleeve in the frame of rod

$$-kx + m \omega^2 x = m \ddot{x}$$

$$\text{or, } \ddot{x} = -\left(\frac{k}{m} - \omega^2\right)x$$

Thus the sought time period

$$T = \frac{2\pi}{\sqrt{\frac{k}{m} - \omega^2}} = 0.7 \text{ s}$$

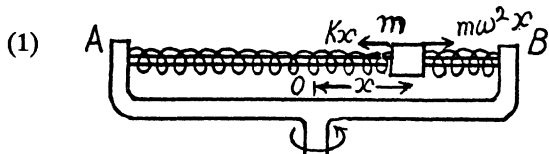

It is obvious from Eqn (1) that the sleeve will not perform small oscillations if

$$\omega \geq \sqrt{\frac{k}{m}} \text{ 10 rad/s.}$$

- 4.32 When the bar is about to start sliding along the plank, it experiences the maximum restoring force which is being provided by the limiting friction,

Thus

$$kN = m \omega_0^2 a \quad \text{or, } kmg = m \omega_0^2 a$$

or,

$$k = \frac{\omega_0^2 a}{g} = \frac{a}{g} \left(\frac{2\pi}{T} \right)^2 = 4 \text{ s.}$$

4.33 The natural angular frequency of a mathematical pendulum equals $\omega_0 = \sqrt{g/l}$

(a) We have the solution of S.H.M. equation in angular form :

$$\theta = \theta_m \cos(\omega_0 t + \alpha)$$

If at the initial moment i.e. at $t = 0$, $\theta = \theta_m$ than $\alpha = 0$.

Thus the above equation takes the form

$$\begin{aligned} \theta &= \theta_m \cos \omega_0 t \\ &= \theta_m \cos \sqrt{\frac{g}{l}} t = 3^\circ \cos \sqrt{\frac{9.8}{0.8}} t \end{aligned}$$

Thus
$$\theta = 3^\circ \cos 3.5 t$$

(b) The S.H.M. equation in angular form :

$$\theta = \theta_m \sin(\omega_0 t + \alpha)$$

If at the initial moment $t = 0$, $\theta = 0$, then $\alpha = 0$. Then the above equation takes the form

$$\theta = \theta_m \sin \omega_0 t$$

Let v_0 be the velocity of the lower end of pendulum at $\theta = 0$, then from conserved of mechanical energy of oscillation

$$E_{\text{mean}} = E_{\text{extreme}} \quad \text{or} \quad T_{\text{mean}} = U_{\text{extrem}}$$

or,

$$\frac{1}{2} m v_0^2 = m g l (1 - \cos \theta_m)$$

Thus

$$\theta_m = \cos^{-1} \left(1 - \frac{v_0^2}{2 g l} \right) = \cos^{-1} \left[1 - \frac{(0.22)^2}{2 \times 9.8 \times 0.8} \right] = 4.5^\circ$$

Thus the sought equation becomes

$$\theta = \theta_m \sin \omega_0 t = 4.5^\circ \sin 3.5 t$$

(c) Let θ_0 and v_0 be the angular deviation and linear velocity at $t = 0$.

As the mechanical energy of oscillation of the mathematical pendulum is conservation

$$\frac{1}{2} m v_0^2 + m g l (1 - \cos \theta_0) = m g l (1 - \cos \theta_m)$$

or,

$$\frac{v_0^2}{2} = g l (\cos \theta_0 - \cos \theta_m)$$

Thus
$$\theta_m = \cos^{-1} \left\{ \cos \theta_0 - \frac{v_0^2}{2 g l} \right\} = \cos^{-1} \left\{ \cos 3^\circ - \frac{(0.22)^2}{2 \times 9.8 \times 0.8} \right\} = 5.4^\circ$$

Then from $\theta = 5.4^\circ \sin(3.5t + \alpha)$, we see that $\sin \alpha = \frac{3}{5.4}$ and $\cos \alpha < 0$ because the velocity is directed towards the centre. Thus $\alpha = \frac{\pi}{2} + 1.0$ radians and we get the answer.

4.34 While the body *A* is at its upper extreme position, the spring is obviously elongated by the amount

$$\left(a - \frac{m_1 g}{\kappa} \right).$$

If we indicate *y*-axis in vertically downward direction, Newton's second law of motion in projection form i.e. $F_y = m w_y$ for body *A* gives :

$$m_1 g + \kappa \left(a - \frac{m_1 g}{\kappa} \right) = m_1 \omega^2 a \quad \text{or,} \quad \kappa \left(a - \frac{m_1 g}{\kappa} \right) = m_1 (\omega^2 a - g) \quad (1)$$

(Because at any extreme position the magnitude of acceleration of an oscillating body equals $\omega^2 a$ and is restoring in nature.)

If *N* be the normal force exerted by the floor on the body *B*, while the body *A* is at its upper extreme position, from Newton's second law for body *B*

$$N + \kappa \left(a - \frac{m_1 g}{\kappa} \right) = m_2 g$$

or,
$$N = m_2 g - \kappa \left(a - \frac{m_1 g}{\kappa} \right) = m_2 g - m_1 (\omega^2 a - g) \quad (\text{using Eqn. 1})$$

Hence
$$N = (m_1 + m_2) g - m_1 \omega^2 a$$

When the body *A* is at its lower extreme position, the spring is compressed by the distance

$$\left(a + \frac{m_1 g}{\kappa} \right).$$

From Newton's second law in projection form i.e. $F_y = m w_y$ for body *A* at this state:

$$m_1 g - \kappa \left(a + \frac{m_1 g}{\kappa} \right) = m_1 (-\omega^2 a) \quad \text{or,} \quad \kappa \left(a + \frac{m_1 g}{\kappa} \right) = m_1 (g + \omega^2 a) \quad (3)$$

In this case if *N'* be the normal force exerted by the floor on the body *B*, From Newton's second law

for body *B* we get:
$$N' = \kappa \left(a + \frac{m_1 g}{\kappa} \right) + m_2 g = m_1 (g + \omega^2 a) + m_2 g \quad (\text{using Eqn. 3})$$

Hence
$$N' = (m_1 + m_2) g + m_1 \omega^2 a$$

From Newton's third law the magnitude of sought forces are *N'* and *N*, respectively.

4.35 (a) For the block from Newton's second law in projection form $F_y = m w_y$,

$$N - m g = m \ddot{y} \quad (1)$$

But from

$$y = a (1 - \cos \omega t)$$

We get
$$\ddot{y} = \omega^2 a \cos \omega t \quad (2)$$

From Eqns (1) and (2)

$$N = m g \left(1 + \frac{\omega^2 a}{g} \cos \omega t \right) \quad (3)$$

From Newton's third law the force by which the body m exerts on the block is directed vertically downward and equals $N = m g \left(1 + \frac{\omega^2 a}{g} \cos \omega t \right)$

- (b) When the body m starts, falling behind the plank or loosing contact, $N = 0$, (because the normal reaction is the contact force). Thus from Eqn. (3)

$$m g \left(1 + \frac{\omega^2 a}{g} \cos \omega t \right) = 0 \quad \text{for some } t.$$

Hence
$$a_{\min} = g/\omega^2 = 8 \text{ cm.}$$

- (c) We observe that the motion takes place about the mean position $y = a$. At the initial instant $y = 0$. As shown in (b) the normal reaction vanishes at a height (g/ω^2) above the position of equilibrium and the body flies off as a free body. The speed of the body at a distance (g/ω^2) from the equilibrium position is $\omega \sqrt{a^2 - (g/\omega^2)^2}$, so that the condition of the problem gives

$$\frac{[\omega \sqrt{a^2 - (g/\omega^2)^2}]^2}{2g} + \frac{g}{\omega^2} + a = h$$

Hence solving the resulting quadratic equation and taking the positive root,

$$a = -\frac{g}{\omega^2} + \sqrt{\frac{2hg}{\omega^2}} = 20 \text{ cm.}$$

- 4.36 (a) Let $y(t)$ = displacement of the body from the end of the unstretched position of the spring (not the equilibrium position). Then

$$m \ddot{y} = -\kappa y + m g$$

This equation has the solution of the form

$$y = A + B \cos(\omega t + \alpha)$$

if
$$-m\omega^2 B \cos(\omega t + \alpha) = -\kappa [A + B \cos(\omega t + \alpha)] + m g$$

Then
$$\omega^2 = \frac{\kappa}{m} \quad \text{and} \quad A = \frac{m g}{\kappa}$$

we have
$$y = 0 \quad \text{and} \quad \dot{y} = 0 \quad \text{at} \quad t = 0. \quad \text{So}$$

$$-\omega B \sin \alpha = 0$$

$$A + B \cos \alpha = 0$$

Since $B > 0$ and $A > 0$ we must have $\alpha = \pi$

$$B = A = \frac{m g}{\kappa}$$

and
$$y = \frac{mg}{\kappa} (1 - \cos \omega t)$$

(b) Tension in the spring is

$$T = \kappa y = mg(1 - \cos \omega t)$$

so

$$T_{\max} = 2mg, T_{\min} = 0$$

4.37 In accordance with the problem

$$\vec{F} = -\alpha m \vec{r}$$

So,
$$m(\ddot{x} \vec{i} + \ddot{y} \vec{j}) = -\alpha m(x \vec{i} + y \vec{j})$$

Thus
$$\ddot{x} = -\alpha x \text{ and } \ddot{y} = -\alpha y$$

Hence the solution of the differential equation

$$\ddot{x} = -\alpha x \text{ becomes } x = a \cos(\omega_0 t + \delta), \text{ where } \omega_0^2 = \alpha \quad (1)$$

So,
$$\dot{x} = -a \omega_0 \sin(\omega_0 t + \alpha) \quad (2)$$

From the initial conditions of the problem, $v_x = 0$ and $x = r_0$ at $t = 0$

So from Eqn. (2) $\alpha = 0$, and Eqn takes the form

$$x = r_0 \cos \omega_0 t \quad \text{so, } \cos \omega_0 t = x/r_0 \quad (3)$$

One of the solution of the other differential Eqn $\ddot{y} = -\alpha y$, becomes

$$y = a' \sin(\omega_0 t + \delta'), \text{ where } \omega_0^2 = \alpha \quad (4)$$

From the initial condition, $y = 0$ at $t = 0$, so $\delta' = 0$ and Eqn (4) becomes :

$$y = a' \sin \omega_0 t \quad (5)$$

Differentiating w.r.t. time we get

$$\dot{y} = a' \omega_0 \cos \omega_0 t \quad (6)$$

But from the initial condition of the problem, $\dot{y} = v_0$ at $t = 0$,

So, from Eqn (6)
$$v_0 = a' \omega_0 \quad \text{or, } a' = v_0/\omega_0$$

Using it in Eqn (5), we get

$$y = \frac{v_0}{\omega_0} \sin \omega_0 t \quad \text{or } \sin \omega_0 t = \frac{\omega_0 y}{v_0} \quad (7)$$

Squaring and adding Eqns (3) and (7) we get :

$$\sin^2 \omega_0 t + \cos^2 \omega_0 t = \frac{\omega_0^2 y^2}{v_0^2} + \frac{x^2}{r_0^2}$$

or,
$$\left(\frac{x}{r_0}\right)^2 + \alpha \left(\frac{y}{v_0}\right)^2 = 1 \quad \left(\text{as } \alpha = \omega_0^2\right)$$

4.38 (a) As the elevator car is a translating non-inertial frame, therefore the body m will experience an inertial force $m w$ directed downward in addition to the real forces in the elevator's frame. From the Newton's second law in projection form

$F_y = m w_y$ for the body in the frame of elevator car:

$$-\kappa \left(\frac{mg}{\kappa} + y\right) + mg + m w = m \ddot{y} \quad (A)$$

(Because the initial elongation in the spring is $m g / \kappa$)

$$\text{so,} \quad m \ddot{y} = -\kappa y + m w = -\kappa \left(y - \frac{m w}{\kappa} \right)$$

$$\text{or,} \quad \frac{d^2}{dt^2} \left(y - \frac{m w}{\kappa} \right) = -\frac{\kappa}{m} \left(y - \frac{m w}{\kappa} \right) \quad (1)$$

Eqn. (1) shows that the motion of the body m is S.H.M. and its solution becomes

$$y - \frac{m w}{\kappa} = a \sin \left(\sqrt{\frac{\kappa}{m}} t + \alpha \right) \quad (2)$$

Differentiating Eqn (2) w.r.t. time

$$\dot{y} = a \sqrt{\frac{\kappa}{m}} \cos \left(\sqrt{\frac{\kappa}{m}} t + \alpha \right) \quad (3)$$

Using the initial condition $y(0) = 0$ in Eqn (2), we get :

$$a \sin \alpha = -\frac{m w}{\kappa}$$

and using the other initial condition $\dot{y}(0) = 0$ in Eqn (3)

$$\text{we get} \quad a \sqrt{\frac{\kappa}{m}} \cos \alpha = 0$$

$$\text{Thus} \quad \alpha = -\alpha/2 \quad \text{and} \quad a = \frac{m w}{\kappa}$$

Hence using these values in Eqn (2), we get

$$y = \frac{m w}{\kappa} \left(1 - \cos \sqrt{\frac{\kappa}{m}} t \right)$$

(b) Proceed up to Eqn.(1). The solution of this differential Eqn be of the form :

$$y - \frac{m w}{\kappa} = a \sin \left(\sqrt{\frac{\kappa}{m}} t + \delta \right)$$

$$\text{or,} \quad y - \frac{\alpha t}{\kappa/m} = a \sin \left(\sqrt{\frac{\kappa}{m}} t + \delta \right)$$

$$\text{or,} \quad y - \frac{\alpha t}{\omega_0^2} = a \sin (\omega_0 t + \delta) \quad \left(\text{where } \omega_0 = \sqrt{\frac{\kappa}{m}} \right) \quad (4)$$

From the initial condition that at $t = 0$, $y(0) = 0$, so $0 = a \sin \delta$ or $\delta = 0$

$$\text{Thus Eqn.(4) takes the form : } y - \frac{\alpha t}{\omega_0^2} = a \sin \omega_0 t \quad (5)$$

$$\text{Differentiating Eqn. (5) we get : } \dot{y} - \frac{\alpha}{\omega_0^2} = a \omega_0 \cos \omega_0 t \quad (6)$$

But from the other initial condition $\dot{y}(0) = 0$ at $t = 0$.

$$\text{So, from Eqn.(6)} \quad -\frac{\alpha}{\omega_0^2} = a \omega_0 \quad \text{or} \quad a = -\alpha/\omega_0^3$$

Putting the value of a in Eqn. (5), we get the sought $y(t)$. i.e.

$$y - \frac{\alpha t}{\omega_0^2} = -\frac{\alpha}{\omega_0^3} \sin \omega_0 t \quad \text{or} \quad y = \frac{\alpha}{\omega_0^3} (\omega_0 t - \sin \omega_0 t)$$

- 4.39** There is an important difference between a rubber cord or steel coire and a spring. A spring can be pulled or compressed and in both cases, obey's Hooke's law. But a rubber cord becomes loose when one tries to compress it and does not then obey Hooke's law. Thus if we suspend a body by a rubber cord it stretches by a distance mg/κ in reaching the equilibrium configuration. If we further stretch it by a distance Δh it will execute harmonic oscillations when released if $\Delta h \leq mg/\kappa$ because only in this case will the cord remain taut and obey Hooke's law.

Thus

$$\Delta h_{\max} = mg/\kappa$$

The energy of oscillation in this case is

$$\frac{1}{2} \kappa (\Delta h_{\max})^2 = \frac{1}{2} \frac{m^2 g^2}{\kappa}$$

- 4.40** As the pan is of negligible mass, there is no loss of kinetic energy even though the collision is inelastic. The mechanical energy of the body m in the field generated by the joint action of both the gravity force and the elastic force is conserved i.e. $\Delta E = 0$. During the motion of the body m from the initial to the final (position of maximum compression of the spring) position $\Delta T = 0$, and therefore $\Delta U = \Delta U_{gr} + \Delta U_{sp} = 0$

or

$$-mg(h+x) + \frac{1}{2} \kappa x^2 = 0$$

On solving the quadratic equation :

$$x = \frac{mg}{\kappa} \pm \sqrt{\frac{m^2 g^2}{\kappa^2} + \frac{2mgh}{\kappa}}$$

As minus sign is not acceptable

$$x = \frac{mg}{\kappa} + \sqrt{\frac{m^2 g^2}{\kappa^2} + \frac{2mgh}{\kappa}}$$

If the body m were at rest on the spring, the corresponding position of m will be its equilibrium position and at this position the resultant force on the body m will be zero. Therefore the equilibrium compression Δx (say) due to the body m will be given by

$$\kappa \Delta x = mg \quad \text{or} \quad \Delta x = mg/\kappa$$

Therefore seperation between the equilibrium position and one of the extreme position i.e. the sought amplitude

$$a = x - \Delta x = \sqrt{\frac{m^2 g^2}{\kappa^2} + \frac{2mgh}{\kappa}}$$

The mechanical energy of oscillation which is conserved equals $E = U_{\text{extreme}}$, because at the extreme position kinetic energy becomes zero.

Although the weight of body m is a conservative force, it is not restoring in this problem, hence U_{extreme} is only concerned with the spring force. Therefore

$$E = U_{\text{extreme}} = \frac{1}{2} \kappa a^2 = m g h + \frac{m^2 g^2}{2 \kappa}$$

4.41 Unlike the previous (4.40) problem the kinetic energy of body m decreases due to the perfectly inelastic collision with the pan. Obviously the body m comes to strike the pan with velocity $v_0 = \sqrt{2 g h}$. If v be the common velocity of the "body m + pan" system due to the collision then from the conservation of linear momentum

$$m v_0 = (M + m) v$$

$$\text{or } v = \frac{m v_0}{(M + m)} = \frac{m \sqrt{2 g h}}{(M + m)} \quad 1)$$

At the moment the body m strikes the pan, the spring is compressed due to the weight of the pan by the amount $M g / \kappa$. If l be the further compression of the spring due to the velocity acquired by the "pan - body m " system, then from the conservation of mechanical energy of the said system in the field generated by the joint action of both the gravity and spring forces

$$\frac{1}{2} (M + m) v^2 + (M + m) g l = \frac{1}{2} \kappa \left(\frac{M g}{\kappa} + l \right)^2 - \frac{1}{2} \kappa \left(\frac{M g}{\kappa} \right)^2$$

$$\text{or, } \frac{1}{2} (M + m) \frac{m^2 2 g h}{(M + m)} + (M + m) g l = \frac{1}{2} \kappa \left(\frac{M g}{\kappa} \right)^2 + \frac{1}{2} \kappa l^2 + M g l - \frac{1}{2} \kappa \left(\frac{M g}{\kappa} \right)^2 \quad (\text{Using 1})$$

$$\text{or, } \frac{1}{2} \kappa l^2 - m g l - \frac{m^2 g h}{(m + M)} = 0$$

$$\text{Thus } l = \frac{m g \pm \sqrt{m^2 g^2 + \frac{2 \kappa g h m^2}{M + m}}}{\kappa}$$

As minus sign is not acceptable

$$l = \frac{m g}{\kappa} + \frac{1}{\kappa} \sqrt{m^2 g^2 + \frac{2 \kappa m^2 g h}{M + m}}$$

If the oscillating "pan + body m " system were at rest it correspond to their equilibrium position

i.e. the spring were compressed by $\frac{(M + m) g}{\kappa}$ therefore the amplitude of oscillation

$$a = l - \frac{m g}{\kappa} = \frac{m g}{\kappa} \sqrt{1 + \frac{2 h \kappa}{m g}}$$

The mechanical energy of oscillation which is only conserved with the restoring forces becomes $E = U_{extreme} = \frac{1}{2} \kappa a^2$ (Because spring force is the only restoring force not the weight of the body)

Alternately
$$E = T_{mean} = \frac{1}{2} (M + m) a^2 \omega^2$$

thus
$$E = \frac{1}{2} (M + m) a^2 \left(\frac{\kappa}{M + m} \right) = \frac{1}{2} \kappa a^2$$

4.42 We have $\vec{F} = a (\dot{y} \vec{i} - \dot{x} \vec{j})$

or,
$$m (\ddot{x} \vec{i} + \ddot{y} \vec{j}) = a (\dot{y} \vec{i} - \dot{x} \vec{j})$$

So,
$$m \ddot{x} = a \dot{y} \text{ and } m \ddot{y} = -a \dot{x} \quad (1)$$

From the initial condition, at $t = 0$, $\dot{x} = 0$ and $y = 0$

So, integrating Eqn, $m \ddot{x} = a \dot{y}$

we get
$$\dot{x} = a y \text{ or } \dot{x} = \frac{a}{m} y \quad (2)$$

Using Eqn (2) in the Eqn $m \ddot{y} = -a \dot{x}$, we get

$$m \ddot{y} = -\frac{a^2}{m} y \text{ or } \ddot{y} = -\left(\frac{a}{m}\right)^2 y \quad (3)$$

one of the solution of differential Eqn (3) is

$$y = A \sin(\omega_0 t + \alpha), \text{ where } \omega_0 = a/m.$$

As at $t = 0$, $y = 0$, so the solution takes the form $y = A \sin \omega_0 t$

On differentiating w.r.t. time $\dot{y} = A \omega_0 \cos \omega_0 t$

From the initial condition of the problem, at $t = 0$, $\dot{y} = v_0$

So,
$$v_0 = A \omega_0 \text{ or } A = v_0/\omega_0$$

Thus
$$y = (v_0/\omega_0) \sin \omega_0 t \quad (4)$$

Thus from (2) $\dot{x} = v_0 \sin \omega_0 t$ so integrating

$$x = B - \frac{v_0}{\omega_0} \cos \omega_0 t \quad (5)$$

On using $x = 0$ at $t = 0$, $B = \frac{v_0}{\omega_0}$

Hence finally
$$x = \frac{v_0}{\omega_0} (1 - \cos \omega_0 t) \quad (6)$$

Hence from Eqns (4) and (6) we get

$$[x - (v_0/\omega_0)]^2 + y^2 = (v_0/\omega_0)^2$$

which is the equation of a circle of radius (v_0/ω_0) with the centre at the point $x_0 = v_0/\omega_0$, $y_0 = 0$

4.43 If water has frozen, the system consisting of the light rod and the frozen water in the hollow sphere constitute a compound (physical) pendulum to a very good approximation because we can take the whole system to be rigid. For such systems the time period is given by

$$T_1 = 2\pi \sqrt{\frac{l}{g}} \sqrt{1 + \frac{k^2}{l^2}} \quad \text{where} \quad k^2 = \frac{2}{5} R^2 \text{ is the radius of gyration of the sphere.}$$

The situation is different when water is unfrozen. When dissipative forces (viscosity) are neglected, we are dealing with ideal fluids. Such fluids instantaneously respond to (unbalanced) internal stresses. Suppose the sphere with liquid water actually executes small rigid oscillations. Then the portion of the fluid above the centre of the sphere will have a greater acceleration than the portion below the centre because the linear acceleration of any element is in this case, equal to angular acceleration of the element multiplied by the distance of the element from the centre of suspension (Recall that we are considering small oscillations). Then, as is obvious in a frame moving with the centre of mass, there will appear an unbalanced couple (not negated by any pseudoforces) which will cause the fluid to move rotationally so as to destroy differences in acceleration. Thus for this case of ideal fluids the pendulum must move in such a way that the elements of the fluid all undergo the same acceleration. This implies that we have a simple (mathematical) pendulum with the time period :

$$T_0 = 2\pi \sqrt{\frac{l}{g}}$$

Thus

$$T_1 = T_0 \sqrt{1 + \frac{2}{5} \left(\frac{R}{l}\right)^2}$$

(One expects that a liquid with very small viscosity will have a time period close T_0 while one with high viscosity will have a time period closer to T_1 .)

4.44 Let us locate the rod at the position when it makes an angle θ from the vertical. In this problem both, the gravity and spring forces are restoring conservative forces, thus from the conservation of mechanical energy of oscillation of the oscillating system :

$$\frac{1}{2} \frac{m l^2}{3} (\dot{\theta})^2 + m g \frac{l}{2} (1 - \cos \theta) + \frac{1}{2} \kappa (l \theta)^2 = \text{constant}$$

Differentiating w.r.t. time, we get :

$$\frac{1}{2} \frac{m l^2}{3} 2 \dot{\theta} \ddot{\theta} + \frac{m g l}{2} \sin \theta \dot{\theta} + \frac{1}{2} \kappa l^2 2 \theta \dot{\theta} = 0$$

Thus for very small θ

$$\ddot{\theta} = -\frac{3g}{2l} \left(1 + \frac{\kappa l}{mg}\right) \theta$$

Hence,

$$\omega_0 = \sqrt{\frac{3g}{2l} \left(1 + \frac{\kappa l}{mg}\right)}.$$

- 4.45 (a) Let us locate the system when the threads are deviated through an angle $\alpha' < \alpha$, during the oscillations of the system (Fig.). From the conservation of mechanical energy of the system :

$$\frac{1}{2} \frac{mL^2}{12} \dot{\theta}^2 + mgl(1 - \cos \alpha') = \text{constant} \quad (1)$$

Where L is the length of the rod, θ is the angular deviation of the rod from its equilibrium position i.e. $\theta = 0$.

Differentiating Eqn. (1) w.r.t. time

$$\frac{1}{2} \frac{mL^2}{12} 2 \dot{\theta} \ddot{\theta} + mgl \sin \alpha' \dot{\alpha}' = 0$$

$$\text{So,} \quad \frac{L^2}{12} \dot{\theta} \ddot{\theta} + gl \alpha' \dot{\alpha}' = 0 \quad (\text{for small } \alpha', \sin \alpha' \approx \alpha') \quad (2)$$

But from the Fig.

$$\frac{L}{2} \theta = l \alpha' \quad \text{or} \quad \alpha' = \frac{L}{2l} \theta$$

$$\text{So,} \quad \dot{\alpha}' = \frac{L}{2l} \dot{\theta}$$

Putting these values of α' and $\frac{d\alpha'}{dt}$ in Eqn. (2) we get

$$\frac{d^2 \theta}{dt^2} = - \frac{3g}{l} \theta$$

Thus the sought time period

$$T = \frac{2\pi}{\omega_0} = 2\pi \sqrt{\frac{l}{3g}}$$

- (b) The sought oscillation energy

$$\begin{aligned} E &= U_{\text{extreme}} = mgl(1 - \cos \alpha) = mgl2 \sin^2 \frac{\alpha}{2} \\ &\approx mgl2 \frac{\alpha^2}{4} = \frac{mgl\alpha^2}{2} \quad (\text{because for small angle } \sin \theta \approx \theta) \end{aligned}$$

4.46 The K.E. of the disc is $\frac{1}{2} I \dot{\varphi}^2 = \frac{1}{2} \left(\frac{mR^2}{2} \right) \dot{\varphi}^2 = \frac{1}{4} mR^2 \dot{\varphi}^2$

The torsional potential energy is $\frac{1}{2} k \varphi^2$. Thus the total energy is :

$$\frac{1}{4} mR^2 \dot{\varphi}^2 + \frac{1}{2} k \varphi^2 = \frac{1}{4} mR^2 \dot{\varphi}_0^2 + \frac{1}{2} k \varphi_0^2$$

By definition of the amplitude φ_m , $\dot{\varphi} = 0$ when $\varphi = \varphi_m$. Thus total energy is

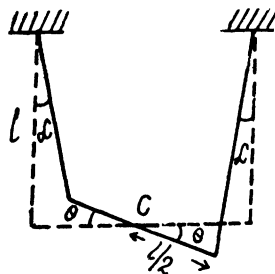

$$\frac{1}{2} k \varphi_m^2 = \frac{1}{4} m R^2 \dot{\varphi}_0^2 + \frac{1}{2} k \varphi_0^2$$

or

$$\varphi_m = \varphi_0 \sqrt{1 + \frac{m R^2}{2k} \frac{\dot{\varphi}_0^2}{\varphi_0^2}}$$

4.47 Moment of inertia of the rod equals $\frac{m l^2}{3}$ about its one end and perpendicular to its length

Thus rotational kinetic energy of the rod = $\frac{1}{2} \left(\frac{m l^2}{3} \right) \dot{\theta}^2 = \frac{m l^2}{6} \dot{\theta}^2$

when the rod is displaced by an angle θ its C.G. goes up by a distance $\frac{l}{2} (1 - \cos \theta) \approx \frac{l \theta^2}{4}$ for small θ .

Thus the P.E. becomes : $m g \frac{l \theta^2}{4}$

As the mechanical energy of oscillation of the rod is conserved.

$$\frac{1}{2} \left(\frac{m l^2}{3} \right) \dot{\theta}^2 + \frac{1}{2} \left(\frac{m g l}{2} \right) \theta^2 = \text{Constant}$$

on differentiating w.r.t. time and for the simplifies we get : $\ddot{\theta} = - \frac{3g}{2l} \theta$ for small θ .

we see that the angular frequency ω is

$$= \sqrt{3g/2l}$$

we write the general solution of the angular oscillation as :

$$\theta = A \cos \omega t + B \sin \omega t$$

But $\theta = \theta_0$ at $t = 0$, so $A = \theta_0$

and $\dot{\theta} = \dot{\theta}_0$ at $t = 0$, so

$$B = \dot{\theta}_0 / \omega$$

Thus
$$\theta = \theta_0 \cos \omega t + \frac{\dot{\theta}_0}{\omega} \sin \omega t$$

Thus the K.E. of the rod

$$\begin{aligned} T &= \frac{m l^2}{6} \dot{\theta}^2 = [-\omega \theta_0 \sin \omega t + \dot{\theta}_0 \cos \omega t]^2 \\ &= \frac{m l^2}{6} [\dot{\theta}_0^2 \cos^2 \omega t + \omega^2 \theta_0^2 \sin^2 \omega t - 2 \omega \theta_0 \dot{\theta}_0 \sin \omega t \cos \omega t] \end{aligned}$$

On averaging over one time period the last term vanishes and $\langle \sin^2 \omega t \rangle = \langle \cos^2 \omega t \rangle = 1/2$. Thus

$$\langle T \rangle = \frac{1}{12} m l^2 \dot{\theta}_0^2 + \frac{1}{8} m g l^2 \theta_0^2 \quad (\text{where } \omega^2 = 3g/2l)$$

- 4.48 Let l = distance between the C.G. (C) of the pendulum and its point of suspension O . Originally the pendulum is in inverted position and its C.G. is above O . When it falls to the normal (stable) position of equilibrium its C.G. has fallen by a distance $2l$. In the equilibrium position the total energy is equal to K.E. = $\frac{1}{2}I\omega^2$ and we have from energy conservation :

$$\frac{1}{2}I\omega^2 = m g 2l \quad \text{or} \quad I = \frac{4 m g l}{\omega^2}$$

Angular frequency of oscillation for a physical pendulum is given by $\omega_0^2 = m g l / I$

Thus
$$T = 2\pi \sqrt{\frac{I}{m g l}} = 2\pi \sqrt{\frac{4 m g l / \omega^2}{m g l}} = \frac{4\pi}{3}$$

- 4.49 Let, moment of inertia of the pendulum, about the axis, concerned is I , then writing $N_z = I\beta_z$ for the pendulum,

$$-m g x \sin a \theta = I \ddot{\theta} \quad \text{or,} \quad \ddot{\theta} = -\frac{m g x}{I} \theta \quad (\text{For small } \theta)$$

which is the required equation for S.H.M. So, the frequency of oscillation,

$$\omega_1 = \sqrt{\frac{M g x}{I}} \quad \text{or,} \quad x = \frac{I}{M g} \sqrt{\omega_1^2} \quad (1)$$

Now, when the mass m is attached to the pendulum, at a distance l below the oscillating axis,

$$-M g x \sin \theta' - m g l \sin \theta' = (I + m l^2) \frac{d^2 \theta'}{dt^2}$$

or,
$$-\frac{g(Mx + ml)}{(I + ml^2)} \theta' = \frac{d^2 \theta}{dt^2}, \quad (\text{For small } \theta)$$

which is again the equation of S.H.M., So, the new frequency,

$$\omega_2 = \sqrt{\frac{g(Mx + ml)}{(I + ml^2)}} \quad (2)$$

Solving Eqns. (1) and (2),

$$\omega_2 = \sqrt{\frac{g((I/g)\omega_1^2 + ml)}{(I + ml^2)}}$$

or,
$$\omega_2^2 = \frac{I\omega_1^2 + m g l}{I + m l^2}$$

or,
$$I(\omega_2^2 - \omega_1^2) = m g l - m \omega_2^2 l^2$$

and hence,
$$I = m l^2 (\omega_2^2 - g/l) / (\omega_1^2 - \omega_2^2) = 0.8 g \cdot m^2$$

4.50 When the two pendulums are joined rigidly and set to oscillate, each exert torques on the other, these torques are equal and opposite. We write the law of motion for the two pendulums as

$$I_1 \ddot{\theta} = -\omega_1^2 I_1 \theta + G$$

$$I_2 \ddot{\theta} = -\omega_2^2 I_2 \theta - G$$

where $\pm G$ is the torque of mutual interactions. We have written the restoring forces on each pendulum in the absence of the other as $-\omega_1^2 I_1 \theta$ and $-\omega_2^2 I_2 \theta$ respectively. Then

$$\ddot{\theta} = -\frac{I_1 \omega_1^2 + I_2 \omega_2^2}{I_1 + I_2} \theta = -\omega^2 \theta$$

Hence

$$\omega = \sqrt{\frac{I_1 \omega_1^2 + I_2 \omega_2^2}{I_1 + I_2}}$$

4.51 Let us locate the rod when it is at small angular position θ relative to its equilibrium position. If a be the sought distance, then from the conservation of mechanical energy of oscillation

$$m g a (1 - \cos \theta) + \frac{1}{2} I_{OO'} (\dot{\theta})^2 = \text{constant}$$

Differentiating w.r.t. time we get :

$$m g a \sin \theta \dot{\theta} + \frac{1}{2} I_{OO'} 2 \dot{\theta} \ddot{\theta} = 0$$

But $I_{OO'} = \frac{m l^2}{12} + m a^2$ and for small θ , $\sin \theta = \theta$, we get

$$\ddot{\theta} = -\left(\frac{g a}{\frac{l^2}{12} + a^2}\right) \theta$$

Hence the time period of one full oscillation becomes

$$T = 2\pi \sqrt{\frac{\frac{l^2}{12} + a^2}{a g}} \quad \text{or} \quad T^2 = \frac{4\pi^2}{g} \left(\frac{l^2}{12a} + a\right)$$

For T_{\min} , obviously $\frac{d}{da} \left(\frac{l^2}{12a} + a\right) = 0$

So, $-\frac{l^2}{12a^2} + 1 = 0$ or $a = \frac{l}{2\sqrt{3}}$

Hence $T_{\min} = 2\pi \sqrt{\frac{l}{g\sqrt{3}}}$

4.52 Consider the moment of inertia of the triangular plate about AB .

$$\begin{aligned}
 I &= \iint x^2 dm = \iint x^2 \rho dx dy \\
 &= \int_0^h x^2 \rho dx \frac{h-x}{h} \cdot \frac{2h}{\sqrt{3}} = \int_0^h x^2 \frac{2\rho}{\sqrt{3}} (h-x) dx \\
 &= \frac{2\rho}{\sqrt{3}} \left(\frac{h^4}{3} - \frac{h^4}{4} \right) = \frac{\rho h^4}{6\sqrt{3}} = \frac{m h^2}{6}
 \end{aligned}$$

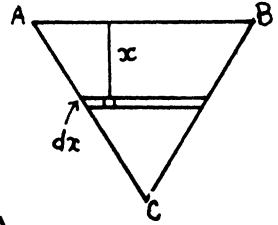

On using the area of the triangle $\Delta ABC = \frac{h^2}{\sqrt{3}}$ and $m = \rho \Delta$.

Thus K.E.
$$= \frac{1}{2} \frac{m h^2}{6} \dot{\theta}^2$$

P.E.
$$= m g \frac{h}{3} (1 - \cos \theta) = \frac{1}{2} m g h \frac{\theta^2}{3}$$

Here θ is the angle that the instantaneous plane of the plate makes with the equilibrium position which is vertical. (The plate rotates as a rigid body)

Thus
$$E = \frac{1}{2} \frac{m h^2}{6} \dot{\theta}^2 + \frac{1}{2} \frac{m g h}{3} \theta^2$$

Hence
$$\omega^2 = \frac{2g}{h} = \frac{m g h}{3} / \frac{m h^2}{6}$$

So
$$T = 2\pi \sqrt{\frac{h}{2g}} = \pi \sqrt{\frac{2h}{g}} \quad \text{and} \quad l_{\text{reduced}} = h/2.$$

4.53 Let us go to the rotating frame, in which the disc is stationary. In this frame the rod is subjected to coriolis and centrifugal forces, F_{cor} and F_{cf} , where

$$F_{cor} = \int 2 dm (\mathbf{v}' \times \vec{\omega}_0) \quad \text{and} \quad F_{cf} = \int dm \omega_0^2 \mathbf{r},$$

where \mathbf{r} is the position of an elemental mass of the rod (Fig.) with respect to point O (disc's centre) and

$$\mathbf{v}' = \frac{d\mathbf{r}'}{dt}$$

As
$$\mathbf{r} = \mathbf{OP} = \mathbf{OA} + \mathbf{AP}$$

So,
$$\frac{d\mathbf{r}}{dt} = \frac{d(\mathbf{AP})}{dt} = \mathbf{v}' \quad \text{(as OA is constant)}$$

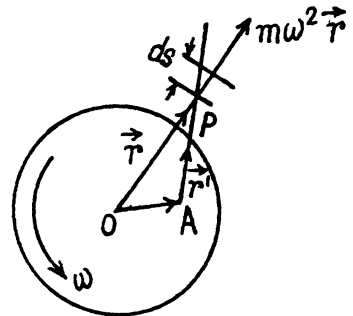

As the rod is vibrating transversely, so \mathbf{v}' is directed perpendicular to the length of the rod. Hence $2 dm (\mathbf{v}' \times \vec{\omega})$ for each elemental mass of the rod is directed along \mathbf{PA} . Therefore the net torque of coriolis about A becomes zero. The net torque of centrifugal force about point A :

Now,
$$\vec{\tau}_{cf(A)} = \int \mathbf{AP} \times dm \omega_0^2 \mathbf{r} = \int \mathbf{AP} \times \left(\frac{m}{l} \right) ds \omega_0^2 (\mathbf{OA} + \mathbf{AP})$$

$$\begin{aligned}
 &= \int \mathbf{AP} \times \left(\frac{m}{l} ds \right) \omega_0^2 \mathbf{OA} = \int \frac{m}{l} ds \omega_0^2 s a \sin \theta (-\mathbf{k}) \\
 &= \frac{m}{l} \omega_0^2 a \sin \theta (-\mathbf{k}) \int_0^l s ds = m \omega_0^2 a \frac{l}{2} \sin \theta (-\mathbf{k})
 \end{aligned}$$

So,
$$\tau_{cf(z)} = \vec{\tau}_{cf(A)} \cdot \mathbf{k} = -m \omega_0^2 a \frac{l}{2} \sin \theta$$

According to the equation of rotational dynamics : $\tau_A(z) = I_A \alpha_z$

or,
$$-m \omega_0^2 a \frac{l}{2} \sin \theta = \frac{m l^2}{3} \ddot{\theta}$$

or,
$$\ddot{\theta} = -\frac{3}{2} \frac{\omega_0^2 a}{l} \sin \theta$$

Thus, for small θ ,
$$\ddot{\theta} = -\frac{3}{2} \frac{\omega^2 a}{2l} \theta$$

This implies that the frequency ω_0 of oscillation is $\omega_0 = \sqrt{\frac{3 \omega^2 a}{2l}}$

4.54 The physical system consists with a pulley and the block. Choosing an inertial frame, let us direct the x -axis as shown in the figure.

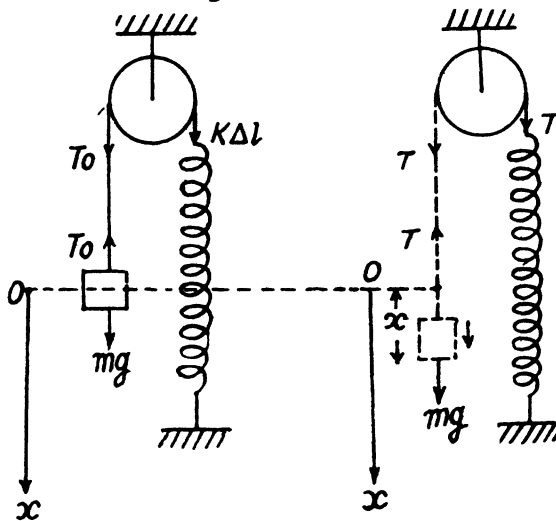

Initially the system is in equilibrium position. Now from the condition of translation equilibrium for the block

$$T_0 = m g \quad (1)$$

Similarly for the rotational equilibrium of the pulley

$$\kappa \Delta / R = T_0 R$$

or,
$$T_0 = \kappa \Delta l \quad (2)$$

from Eqns. (1) and (2)
$$\Delta l = \frac{m g}{\kappa} \quad (3)$$

Now let us disturb the equilibrium of the system no matter in which way to analyse its motion. At an arbitrary position shown in the figure, from Newton's second law of motion for the block

$$\begin{aligned} F_x &= m w_x \\ m g - T &= m w = m \dot{x} \end{aligned} \quad (4)$$

Similarly for the pulley

$$\begin{aligned} N_z &= I \beta_z \\ T R - \kappa (\Delta l + x) R &= I \ddot{\theta} \end{aligned} \quad (5)$$

But $w = \beta R$ or, $\dot{x} = R \ddot{\theta}$ (6)

from (5) and (6)
$$T R - \kappa (\Delta l + x) R = \frac{I}{R} \dot{x} \quad (7)$$

Solving (4) and (7) using the initial condition of the problem

$$-\kappa R x = \left(m R + \frac{I}{R} \right) \dot{x}$$

or,
$$\ddot{x} = - \left(\frac{\kappa}{m + \frac{I}{R^2}} \right) x$$

Hence the sought time period,
$$T = \frac{2\pi}{\omega_0} = 2\pi \sqrt{\frac{m + I/R^2}{\kappa}}$$

Note : we may solve this problem by using the conservation of mechanical energy also

4.55 At the equilibrium position, $N_{Oz} = 0$ (Net torque about O)

So,
$$m_A g R - m g R \sin \alpha = 0 \quad \text{or} \quad m_A = m \sin \alpha \quad (1)$$

From the equation of rotational dynamics of a solid body about the stationary axis (say z-axis) of rotation i.e. from $N_z = I \beta_z$

when the pulley is rotated by the small angular displacement θ in clockwise sense relative to the equilibrium position (Fig.), we get :

$$\begin{aligned} m_A g R - m g R \sin (\alpha + \theta) \\ = \left[\frac{M R^2}{2} + m R^2 + m_A R^2 \right] \ddot{\theta} \end{aligned}$$

Using Eqn. (1)

$$\begin{aligned} m g \sin \alpha - m g (\sin \alpha \cos \theta + \cos \alpha \sin \theta) \\ = \left\{ \frac{M R + 2 m (1 + \sin \alpha) R}{2} \right\} \ddot{\theta} \end{aligned}$$

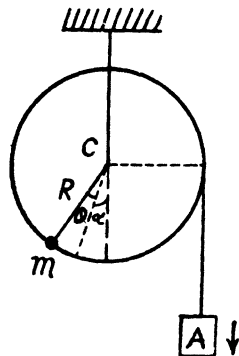

But for small θ , we may write $\cos \theta \approx 1$ and $\sin \theta \approx \theta$

Thus we have

$$m g \sin \alpha - m g (\sin \alpha + \cos \alpha \theta) = \frac{\{MR + 2m(1 + \sin \alpha)R\}}{2} \ddot{\theta}$$

Hence,
$$\ddot{\theta} = - \frac{2mg \cos \alpha}{[MR + 2m(1 + \sin \alpha)R]} \theta$$

Hence the sought angular frequency $\omega_0 = \sqrt{\frac{2mg \cos \alpha}{MR + 2mR(1 + \sin \alpha)}}$

4.56 Let us locate solid cylinder when it is displaced from its stable equilibrium position by the small angle θ during its oscillations (Fig.). If v_c be the instantaneous speed of the C.M. (C) of the solid cylinder which is in pure rolling, then its angular velocity about its own centre C is

$$\omega = v_c / r \quad (1)$$

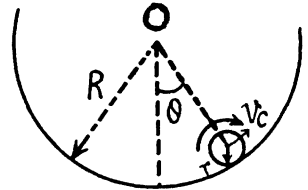

Since C moves in a circle of radius $(R - r)$, the speed of C at the same moment can be written as

$$v_c = \dot{\theta} (R - r) \quad (2)$$

Thus from Eqns (1) and (2)

$$\omega = \dot{\theta} \frac{(R - r)}{r} \quad (3)$$

As the mechanical energy of oscillation of the solid cylinder is conserved, i.e. $E = T + U = \text{constant}$

$$\text{So, } \frac{1}{2} m v_c^2 + \frac{1}{2} I_c \omega^2 + m g (R - r) (1 - \cos \theta) = \text{constant}$$

(Where m is the mass of solid cylinder and I_c is the moment of inertia of the solid cylinder about an axis passing through its C.M. (C) and perpendicular to the plane of Fig. of solid cylinder)

$$\text{or, } \frac{1}{2} m \omega^2 r^2 + \frac{1}{2} \frac{m r^2}{2} \omega^2 + m g (R - r) (1 - \cos \theta) = \text{constant} \quad (\text{using Eqn (1) and } I_c = m r^2 / 2)$$

$$\frac{3}{4} r^2 (\dot{\theta})^2 \frac{(R - r)^2}{r^2} + g (R - r) (1 - \cos \theta) = \text{constant, (using Eqn. 3)}$$

Differentiating w.r.t. time

$$\frac{3}{4} (R - r) 2 \dot{\theta} \ddot{\theta} + g \sin \theta \dot{\theta} = 0$$

So,
$$\ddot{\theta} = - \frac{2g}{3(R - r)} \theta, \text{ (because for small } \theta, \sin \theta \approx \theta \text{)}$$

Thus
$$\omega_0 = \sqrt{\frac{2g}{3(R - r)}}$$

Hence the sought time period

$$T = \frac{2\pi}{\omega_0} = 2\pi \sqrt{\frac{3(R-r)}{2g}}$$

4.57 Let κ_1 and κ_2 be the spring constant of left and right sides springs. As the rolling of the solid cylinder is pure its lowest point becomes the instantaneous centre of rotation. If θ be the small angular displacement of its upper most point relative to its equilibrium position, the deformation of each spring becomes $(2R\theta)$. Since the mechanical energy of oscillation of the solid cylinder is conserved, $E = T + U = \text{constant}$

$$\text{i.e.} \quad \frac{1}{2} I_P (\dot{\theta})^2 + \frac{1}{2} \kappa_1 (2R\theta)^2 + \frac{1}{2} \kappa_2 (2R\theta)^2 = \text{constant}$$

Differentiating w.r.t. time

$$\frac{1}{2} I_P 2 \dot{\theta} \ddot{\theta} + \frac{1}{2} (\kappa_1 + \kappa_2) 4R^2 2\theta \dot{\theta} = 0$$

$$\text{or,} \quad \left(\frac{mR^2}{2} + mR^2 \right) \ddot{\theta} + 4R^2 \kappa \theta = 0$$

$$\text{(Because } I_P = I_C + mR^2 = \frac{mR^2}{2} + mR^2 \text{)}$$

$$\text{Hence} \quad \ddot{\theta} = -\frac{8\kappa}{3m} \theta$$

Thus $\omega_0 = \frac{8\kappa}{3m}$ and sought time period

$$T = \frac{2\pi}{\omega_0} = 2\pi \sqrt{\frac{3m}{8\kappa}} = \pi \sqrt{\frac{3m}{2\kappa}}$$

4.58 In the C.M. frame (which is rigidly attached with the centre of mass of the two cubes) the cubes oscillates. We know that the kinetic energy of two body system equals $\frac{1}{2} \mu v_{\text{rel}}^2$, where μ is the reduced mass and v_{rel} is the modulus of velocity of any one body particle relative to other. From the conservation of mechanical energy of oscillation :

$$\frac{1}{2} \kappa x^2 + \frac{1}{2} \mu \left\{ \frac{d}{dt} (l_0 + x) \right\}^2 = \text{constant}$$

Here l_0 is the natural length of the spring.

Differentiating the above equation w.r.t time, we get :

$$\frac{1}{2} \kappa 2x \dot{x} + \frac{1}{2} \mu 2 \dot{x} \ddot{x} = 0 \left[\text{becomes } \frac{d(l_0 + x)}{dt} = \dot{x} \right]$$

$$\text{Thus } \ddot{x} = -\frac{\kappa}{\mu} x \left(\text{where } \mu = \frac{m_1 m_2}{m_1 + m_2} \right)$$

Hence the natural frequency of oscillation : $\omega_0 = \sqrt{\frac{\kappa}{\mu}}$ where $\mu = \frac{m_1 m_2}{m_1 + m_2}$

4.59 Suppose the balls 1 & 2 are displaced by x_1, x_2 from their initial position. Then the energy

$$\text{is : } E = \frac{1}{2} m_1 \dot{x}_1^2 + m_2 \dot{x}_2^2 + \frac{1}{2} k (x_1 - x_2)^2 = \frac{1}{2} m_1 v_1^2$$

Also total momentum is : $m_1 \dot{x}_1 + m_2 \dot{x}_2 = m_1 v_1$

Define
$$X = \frac{m_1 x_1 + m_2 x_2}{m_1 + m_2}, \quad x = x_1 - x_2$$

Then
$$x_1 = X + \frac{m_2}{m_1 + m_2} x, \quad x_2 = X - \frac{m_1}{m_1 + m_2} x$$

$$E = \frac{1}{2} (m_1 + m_2) \dot{X}^2 + \frac{1}{2} \frac{m_1 m_2}{m_1 + m_2} \dot{x}^2 + \frac{1}{2} k x^2$$

Hence
$$\dot{X} = \frac{m_1 v_1}{m_1 + m_2}$$

So
$$\frac{1}{2} \frac{m_1 m_2}{m_1 + m_2} \dot{x}^2 + \frac{1}{2} k x^2 = \frac{1}{2} m_1 v_1^2 - \frac{1}{2} \frac{m_1^2 v_1^2}{m_1 + m_2} = \frac{1}{2} \frac{m_1 m_2}{m_1 + m_2} v_1^2$$

(a) From the above equation

We see $\omega = \sqrt{\frac{k}{\mu}} = \sqrt{\frac{3 \times 24}{2}} = 6 \text{ s}^{-1}$, when $\mu = \frac{m_1 m_2}{m_1 + m_2} = \frac{2}{3} \text{ kg}$.

(b) The energy of oscillation is

$$\frac{1}{2} \frac{m_1 m_2}{m_2 + m_2} v_1^2 = \frac{1}{2} \frac{2}{3} \times (0.12)^2 = 48 \times 10^{-4} = 4.8 \text{ mJ}$$

We have $x = a \sin (\omega t + \alpha)$

Initially $x = 0$ at $t = 0$ so $\alpha = 0$

Then $x = a \sin \omega t$. Also $x = v_1$ at $t = 0$.

So $\omega a = v_1$ and hence $a = \frac{v_1}{\omega} = \frac{12}{6} = 2 \text{ cm}$.

4.60 Suppose the disc 1 rotates by angle θ_1 and the disc 2 by angle θ_2 in the opposite sense. Then

total torsion of the rod = $\theta_1 + \theta_2$

and torsional P.E. = $\frac{1}{2} \kappa (\theta_1 + \theta_2)^2$

The K.E. of the system (neglecting the moment of inertia of the rod) is

$$\frac{1}{2} I_1 \dot{\theta}_1^2 + \frac{1}{2} I_2 \dot{\theta}_2^2$$

So total energy of the rod

$$E = \frac{1}{2} I_1 \dot{\theta}_1^2 + \frac{1}{2} I_2 \dot{\theta}_2^2 + \frac{1}{2} \kappa (\theta_1 + \theta_2)^2$$

We can put the total angular momentum of the rod equal to zero since the frequency associated with the rigid rotation of the whole system must be zero (and is known).

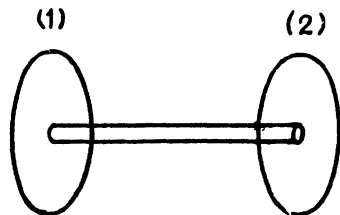

Thus
$$I_1 \dot{\theta}_1 = I_2 \dot{\theta}_2 \quad \text{or} \quad \frac{\dot{\theta}_1}{1/I_1} = \frac{\dot{\theta}_2}{1/I_2} = \frac{\dot{\theta}_1 + \dot{\theta}_2}{1/I_1 + 1/I_2}$$

So
$$\dot{\theta}_1 = \frac{I_2}{I_1 + I_2} (\dot{\theta}_1 + \dot{\theta}_2) \quad \text{and} \quad \dot{\theta}_2 = \frac{I_1}{I_1 + I_2} (\dot{\theta}_1 + \dot{\theta}_2)$$

and
$$E = \frac{1}{2} \frac{I_1 I_2}{I_1 + I_2} (\dot{\theta}_1 + \dot{\theta}_2)^2 + \frac{1}{2} \kappa (\theta_1 + \theta_2)^2$$

The angular oscillation, frequency corresponding to this is

$$\omega^2 = \kappa / \frac{I_1 I_2}{I_1 + I_2} = \kappa / I' \quad \text{and} \quad T = 2\pi \sqrt{\frac{I'}{\kappa}}, \quad \text{where} \quad I' = \frac{I_1 I_2}{I_1 + I_2}$$

4.61 In the first mode the carbon atom remains fixed and the oxygen atoms move in equal & opposite steps. Then total energy is

(1)

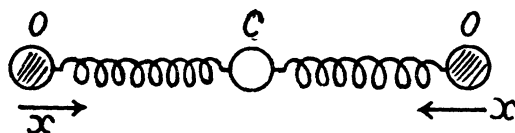

$$\frac{1}{2} 2 m_0 \dot{x}^2 + \frac{1}{2} 2 \kappa x^2$$

where x is the displacement of one of the O atom (say left one). Thus

$$\omega_1^2 = \kappa / m_0.$$

(2)

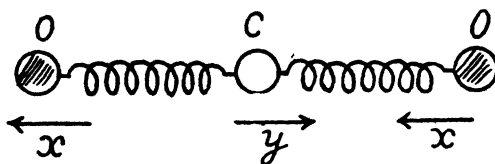

In this mode the oxygen atoms move in equal steps in the same direction but the carbon atom moves in such a way as to keep the centre of mass fixed.

Thus
$$2 m_0 x + m_c y = 0 \quad \text{or} \quad y = -\frac{2 m_0}{m_c} x$$

$$\text{K.E.} = \frac{1}{2} 2 m_0 \dot{x}^2 + \frac{1}{2} m_c \left(\frac{2 m_0}{m_c} \dot{x} \right)^2 = \frac{1}{2} 2 m_0 \dot{x}^2 + \frac{1}{2} 2 m_0 \frac{2 m_0}{m_c} \dot{x}^2 = \frac{1}{2} 2 m_0 \left(1 + \frac{2 m_0}{m_c} \right) \dot{x}^2$$

$$\text{P.E.} = \frac{1}{2} k \left(1 + \frac{2 m_0}{m_c} \right)^2 x^2 + \frac{1}{2} \kappa \left(1 + \frac{2 m_0}{m_c} \right)^2 x^2 = \frac{1}{2} 2 \kappa \left(1 + \frac{2 m_0}{m_c} \right)^2 x^2$$

Thus
$$\omega_2^2 = \frac{\kappa}{m_0} \left(1 + \frac{2 m_0}{m_c} \right) \quad \text{and} \quad \omega_2 = \omega_1 \sqrt{1 + \frac{2 m_0}{m_c}}$$

Hence,
$$\omega_2 = \omega_1 \sqrt{1 + \frac{32}{12}} = \omega_1 \sqrt{\frac{11}{3}} \approx 1.91 \omega_1$$

4.62 Let, us displace the piston through small distance x , towards right, then from $F_x = m w_x$

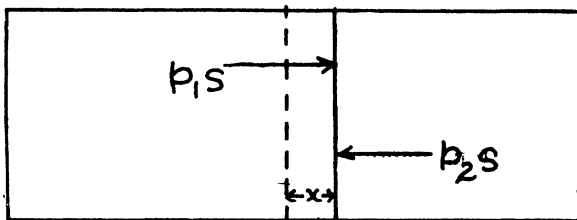

$$\text{or,} \quad (p_1 - p_2) S = -m \ddot{x} \quad (1)$$

But, the process is adiabatic, so from $P V^\gamma = \text{const}$.

$$p_2 = \frac{p_0 V_0^\gamma}{(V_0 - Sx)^\gamma} \quad \text{and} \quad p_1 = \frac{p_0 V_0^\gamma}{(V_0 + Sx)^\gamma},$$

as the new volumes of the left and the right parts are now $(V_0 + Sx)$ and $(V_0 - Sx)$ respectively.

So, the Eqn (1) becomes.

$$\frac{p_0 V_0^\gamma S}{m} \left\{ \frac{1}{(V_0 - Sx)^\gamma} - \frac{1}{(V_0 + Sx)^\gamma} \right\} = -\ddot{x}$$

$$\text{or,} \quad \frac{p_0 V_0^\gamma S}{m} \left\{ \frac{(V_0 + Sx)^\gamma - (V_0 - Sx)^\gamma}{(V_0^2 - S^2 x^2)^\gamma} \right\} = -\ddot{x}$$

$$\text{or,} \quad \frac{p_0 V_0^\gamma S}{m} \left\{ \frac{\left(1 + \frac{\gamma Sx}{V_0}\right) - \left(1 - \frac{\gamma Sx}{V_0}\right)}{V_0^\gamma \left(1 - \frac{\gamma S^2 x^2}{V_0^2}\right)} \right\} = -\ddot{x}$$

Neglecting the term $\frac{\gamma S^2 x^2}{V_0^2}$ in the denominator, as it is very small, we get,

$$\ddot{x} = -\frac{2 p_0 S^2 \gamma x}{m V_0},$$

which is the equation for S.H.M. and hence the oscillating frequency.

$$\omega_0 = S \sqrt{\frac{2 p_0 \gamma}{m V_0}}$$

4.63 In the absence of the charge, the oscillation period of the ball

$$T = 2\pi \sqrt{l/g}$$

when we impart the charge q to the ball, it will be influenced by the induced charges on the conducting plane. From the electric image method the electric force on the ball by the plane

equals $\frac{q^2}{4\pi\epsilon_0 (2h)^2}$ and is directed downward. Thus in this case the effective acceleration

of the ball

$$g' = g + \frac{q^2}{16 \pi \epsilon_0 m h^2}$$

and the corresponding time period

$$T' = 2\pi \sqrt{\frac{l}{g'}} = 2\pi \sqrt{\frac{l}{g + \frac{q^2}{16 \pi \epsilon_0 m h^2}}}$$

From the condition of the problem

$$T = \eta T'$$

So,
$$T^2 = \eta^2 T'^2 \quad \text{or} \quad \frac{1}{g} = \eta^2 \left(\frac{1}{g + \frac{q^2}{16 \pi \epsilon_0 m h^2}} \right)$$

Thus on solving

$$q = 4h \sqrt{\pi \epsilon_0 m g (\eta^2 - 1)} = 2\mu C$$

4.64 In a magnetic field of induction B the couple on the magnet is $-MB \sin \theta = -MB \theta$ equating this to $I\ddot{\theta}$ we get

$$I\ddot{\theta} + MB\theta = 0$$

or
$$\omega^2 = \frac{MB}{I} \quad \text{or} \quad T = 2\pi \sqrt{\frac{I}{MB}}$$

Given

$$T_2 = T_1/\eta$$

∴
$$\sqrt{\frac{1}{B_2}} = \sqrt{\frac{1}{B_1}} \cdot \frac{1}{\eta} \quad \text{or} \quad \frac{1}{B_2} = \frac{1}{B_1} \cdot \frac{1}{\eta^2}$$

or

$$B_2 = \eta^2 B_1$$

The induction of the field increased η^2 times.

4.65 We have in the circuit at a certain instant of time (t), from Faraday's law of electromagnetic induction :

$$L \frac{di}{dt} = Bl \frac{dx}{dt} \quad \text{or} \quad L di = Bl dx$$

As at $t = 0, x = 0$, so $Li = Blx$ or $i = \frac{Bl}{L}x$ (1)

For the rod from the second law of motion $F_x = m w_x$

$$-i l B = m \ddot{x}$$

Using Eqn. (1), we get :
$$\ddot{x} = - \left(\frac{l^2 B^2}{mL} \right) x = -\omega_0^2 x \quad (2)$$

where

$$\omega_0 = lB / \sqrt{mL}$$

The solution of the above differential equation is of the form

$$x = a \sin (\omega_0 t + \alpha)$$

From the initial condition, at $t = 0$, $x = 0$, so $\alpha = 0$

Hence,
$$x = a \sin \omega_0 t \quad (3)$$

Differentiating w.r.t. time, $\dot{x} = a \omega_0 \cos \omega_0 t$

But from the initial condition of the problem at $t = 0$, $\dot{x} = v_0$

Thus
$$v_0 = a \omega_0 \quad \text{or} \quad a = v_0 / \omega_0 \quad (4)$$

Putting the value of a from Eqn. (4) into Eqn. (3), we obtained

$$x = \frac{v_0}{\omega_0} \sin \omega_0 t \quad \left(\text{where } \omega_0 = \frac{lB}{\sqrt{mL}} \right)$$

4.66 As the connector moves, an emf is set up in the circuit and a current flows, since the emf is

$$\xi = -Bl\dot{x}, \text{ we must have : } -Bl\dot{x} + L \frac{dI}{dt} = 0$$

so,
$$I = Blx/L$$

provided x is measured from the initial position.

We then have

$$m\ddot{x} = -\frac{Blx}{L} \cdot Bl + mg$$

for by Lenz's law the induced current will oppose downward sliding. Finally

$$\ddot{x} + \frac{(Bl)^2}{mL} x = g$$

on putting

$$\omega_0 = \frac{Bl}{\sqrt{mL}}$$

$$\ddot{x} + \omega_0^2 x = g$$

A solution of this equation is $x = \frac{g}{\omega_0^2} + A \cos (\omega_0 t + \alpha)$

But $x = 0$ and $\dot{x} = 0$ at $t = 0$. This gives

$$x = \frac{g}{\omega_0^2} (1 - \cos \omega_0 t).$$

4.67 We are given $x = a_0 e^{-\beta t} \sin \omega t$

(a) The velocity of the point at $t = 0$ is obtained from

$$v_0 = (\dot{x})_{t=0} = \omega a_0$$

The term "oscillation amplitude at the moment $t = 0$ " is meaningless. Probably the implication is the amplitude for $t \ll \frac{1}{\beta}$. Then $x \approx a_0 \sin \omega t$ and amplitude is a_0 .

(b)
$$\dot{x} = (-\beta a_0 \sin \omega t + \omega a_0 \cos \omega t) e^{-\beta t} = 0$$

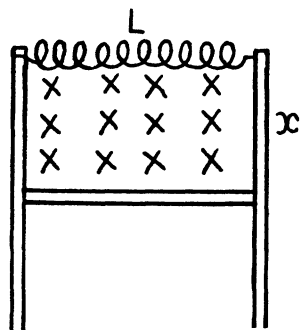

when the displacement is an extremum. Then

$$\tan \omega t = \frac{\omega}{\beta}$$

or
$$\omega t = \tan^{-1} \frac{\omega}{\beta} + n\pi, \quad n = 0, 1, 2, \dots$$

4.68 Given $\varphi = \varphi_0 e^{-\beta t} \cos \omega t$

we have $\dot{\varphi} = -\beta \varphi - \omega \varphi_0 e^{-\beta t} \sin \omega t$

$$\begin{aligned} \dot{\varphi} &= -\beta \dot{\varphi} + \beta \omega \varphi_0 e^{-\beta t} \sin \omega t - \omega^2 \varphi_0 e^{-\beta t} \cos \omega t \\ &= \beta^2 \varphi + 2\beta \omega \varphi_0 e^{-\beta t} \sin \omega t - \omega^2 \varphi \end{aligned}$$

so

(a) $(\dot{\varphi})_0 = -\beta \varphi_0, (\ddot{\varphi})_0 = (\beta^2 - \omega^2) \varphi_0$

(b) $\dot{\varphi} = -\varphi_0 e^{-\beta t} (\beta \cos \omega t + \omega \sin \omega t)$ becomes maximum (or minimum) when

$$\ddot{\varphi} = \varphi_0 (\beta^2 - \omega^2) e^{-\beta t} \cos \omega t + 2\beta \omega \varphi_0 e^{-\beta t} \sin \omega t = 0$$

or

$$\tan \omega t = \frac{\omega^2 - \beta^2}{2\beta\omega}$$

and

$$t_n = \frac{1}{\omega} \left[\tan^{-1} \frac{\omega^2 - \beta^2}{2\beta\omega} + n\pi \right], \quad n = 0, 1, 2, \dots$$

4.69 We write $x = a_0 e^{-\beta t} \cos(\omega t + \alpha)$.

(a) $x(0) = 0 \Rightarrow \alpha = \pm \frac{\pi}{2} \Rightarrow x = \mp a_0 e^{-\beta t} \sin \omega t$

$$\dot{x}(0) = (\dot{x})_{t=0} = \mp \omega a_0$$

Since a_0 is +ve, we must choose the upper sign if $\dot{x}(0) < 0$ and the lower sign if $\dot{x}(0) > 0$. Thus

$$a_0 = \frac{|\dot{x}(0)|}{\omega} \quad \text{and} \quad \alpha = \begin{cases} +\frac{\pi}{2} & \text{if } \dot{x}(0) < 0 \\ -\frac{\pi}{2} & \text{if } \dot{x}(0) > 0 \end{cases}$$

(b) we write $x = \text{Re } A e^{-\beta t + i\omega t}, A = a_0 e^{i\alpha}$

Then $\dot{x} = v_x = \text{Re } (-\beta + i\omega) A e^{-\beta t + i\omega t}$

From $v_x(0) = 0$ we get $\text{Re } (-\beta + i\omega) A = 0$

This implies $A = \pm i(\beta + i\omega) B$ where B is real and positive. Also

$$x_0 = \text{Re } A = \mp \omega B$$

Thus
$$B = \frac{|x_0|}{\omega} \quad \text{with } + \text{ sign in } A \text{ if } x_0 < 0$$

- sign in A if $x_0 > 0$

$$\text{So} \quad A = \pm i \frac{\beta + i\omega}{\omega} |x_0| = \left(\mp 1 + \pm \frac{i\beta}{\omega} \right) |x_0|$$

$$\text{Finally} \quad a_0 = \sqrt{1 + \left(\frac{\beta}{\omega} \right)^2} |x_0|$$

$$\tan \alpha = \frac{-\beta}{\omega}, \quad \alpha = \tan^{-1} \left(\frac{-\beta}{\omega} \right)$$

α is in the 4th quadrant $\left(-\frac{\pi}{2} < \alpha < 0 \right)$ if $x_0 > 0$ and α is in the 2nd quadrant

$\left(\frac{\pi}{2} < \alpha < \pi \right)$ if $x_0 < 0$.

$$4.70 \quad x = a_0 e^{-\beta t} \cos(\omega t + \alpha)$$

$$\text{Then} \quad (\dot{x})_{t=0} = -\beta a_0 \cos \alpha - \omega a_0 \sin \alpha = 0$$

$$\text{or} \quad \tan \alpha = -\frac{\beta}{\omega}$$

$$\text{Also} \quad (x)_{t=0} = a_0 \cos \alpha = \frac{a_0}{\eta}$$

$$\sec^2 \alpha = \eta^2, \quad \tan \alpha = -\sqrt{\eta^2 - 1}$$

$$\text{Thus} \quad \beta = \omega \sqrt{\eta^2 - 1}$$

(We have taken the amplitude at $t = 0$ to be a_0).

$$4.71 \quad \text{We write } x = a_0 e^{-\beta t} \cos(\omega t + \alpha)$$

$$= \text{Re } A e^{-\beta t + i\omega t}, \quad A = a_0 e^{i\alpha}$$

$$\dot{x} = \text{Re } A (-\beta + i\omega) e^{-\beta t + i\omega t}$$

Velocity amplitude as a function of time is defined in the following manner. Put $t = t_0 + \tau$, then

$$\begin{aligned} x &= \text{Re } A e^{-\beta(t_0 + \tau)} e^{i\omega(t_0 + \tau)} \\ &\approx \text{Re } A e^{-\beta t_0} e^{i\omega t_0 + i\omega \tau} \approx \text{Re } A e^{-\beta t_0} e^{i\omega t} \end{aligned}$$

for $\tau \ll \frac{1}{\beta}$. This means that the displacement amplitude around the time t_0 is $a_0 e^{-\beta t_0}$ and we can say that the displacement amplitude at time t is $a_0 e^{-\beta t}$. Similarly for the velocity amplitude.

Clearly

$$(a) \text{ Velocity amplitude at time } t = a_0 \sqrt{\beta^2 + \omega^2} e^{-\beta t}$$

$$\text{Since} \quad A(-\beta + i\omega) = a_0 e^{i\alpha} (-\beta + i\omega)$$

$$= a_0 \sqrt{\beta^2 + \omega^2} e^{i\gamma}$$

where γ is another constant.

(b) $x(0) = 0 \Rightarrow \operatorname{Re} A = 0$ or $A = \pm i a_0$

where a_0 is real and positive.

Also
$$v_x(0) = \dot{x}_0 = \operatorname{Re} \pm i a_0 (-\beta + i\omega)$$

$$= \mp \omega a_0$$

Thus $a_0 = \frac{|\dot{x}_0|}{\omega}$ and we take $- (+)$ sign if x_0 is negative (positive). Finally the velocity amplitude is obtained as

$$\frac{|\dot{x}_0|}{\omega} \sqrt{\beta^2 + \omega^2} e^{-\beta t}.$$

4.72 The first oscillation decays faster in time. But if one takes the natural time scale, the period T for each oscillation, the second oscillation attenuates faster during that period.

4.73 By definition of the logarithmic decrement $\left(\lambda = \beta \frac{2\pi}{\omega} \right)$ we get for the original decrement λ_0

$$\lambda_0 = \beta \frac{2\pi}{\sqrt{\omega_0^2 - \beta^2}} \quad \text{and finally } \lambda = \frac{2\pi n \beta}{\sqrt{\omega_0^2 - n^2 \beta^2}}$$

Now
$$\frac{\beta}{\sqrt{\omega_0^2 - \beta^2}} = \frac{\lambda_0}{2\pi} \quad \text{or} \quad \frac{\beta}{\omega_0} = \frac{\lambda_0/2\pi}{\sqrt{1 + \left(\frac{\lambda_0}{2\pi}\right)^2}}$$

so
$$\frac{\lambda/2\pi}{\sqrt{1 + \left(\frac{\lambda}{2\pi}\right)^2}} = \frac{n \frac{\lambda_0}{2\pi}}{\sqrt{1 + \left(\frac{\lambda_0}{2\pi}\right)^2}}$$

Hence
$$\frac{\lambda}{2\pi} = \frac{n \lambda_0/2\pi}{\sqrt{1 - (n^2 - 1) \left(\frac{\lambda_0}{2\pi}\right)^2}}$$

For critical damping

$$\omega_0 = n_c \beta$$

$$\frac{1}{n_c} = \frac{\beta}{\omega_0} = \frac{\lambda_0/2\pi}{\sqrt{1 + \left(\frac{\lambda_0}{2\pi}\right)^2}} \quad \text{or} \quad n_c = \sqrt{1 + \left(\frac{2\pi}{\lambda_0}\right)^2}$$

4.74 The Eqn of the dead weight is

$$m \ddot{x} + 2\beta m \dot{x} + m \omega_0^2 x = mg$$

so
$$\Delta x = \frac{g}{\omega_0^2} \quad \text{or} \quad \omega_0^2 = \frac{g}{\Delta x}.$$

Now
$$\lambda = \frac{2\pi\beta}{\omega} = \frac{2\pi\beta}{\sqrt{\omega_0^2 - \beta^2}} \quad \text{or} \quad \frac{\omega_0}{\sqrt{\omega_0^2 - \beta^2}} = \sqrt{1 + \left(\frac{\lambda}{2\pi}\right)^2}$$

Thus
$$T = \frac{2\pi}{\sqrt{\omega_0^2 - \beta^2}} = \frac{2\pi}{\omega_0} \sqrt{1 + \left(\frac{\lambda}{2\pi}\right)^2}$$

$$= 2\pi \sqrt{\frac{\Delta x}{g}} \sqrt{1 + \left(\frac{\lambda}{2\pi}\right)^2} = \sqrt{\frac{\Delta x}{g} (4\pi^2 + \lambda^2)} = 0.70 \text{ sec.}$$

4.75 The displacement amplitude decrease η times every n oscillations. Thus

$$\frac{1}{\eta} = e^{-\beta \cdot \frac{2\pi}{\omega} \cdot n}$$

or
$$\frac{2\pi n \beta}{\omega} = \ln \eta \quad \text{or} \quad \frac{\beta}{\omega} = \frac{\ln \eta}{2\pi n}.$$

So
$$Q = \frac{\omega}{2\beta} = \frac{\pi n}{\ln \eta} \approx 499.$$

4.76 From $x = a_0 e^{-\beta t} \cos(\omega t + \alpha)$, we get using

$$(x)_{t=0} = l = a_0 \cos \alpha$$

$$0 = (\dot{x})_{t=0} = -\beta a_0 \cos \alpha - \omega a_0 \sin \alpha$$

Then
$$\tan \alpha = -\frac{\beta}{\omega} \quad \text{or} \quad \cos \alpha = \frac{\omega}{\sqrt{\omega^2 + \beta^2}}$$

and
$$x = \frac{l\sqrt{\omega^2 + \beta^2}}{\omega} e^{-\beta t} \cos\left(\omega t - \tan^{-1} \frac{\beta}{\omega}\right)$$

$$x = 0 \quad \text{at} \quad t = \frac{1}{\omega} \left(n\pi + \frac{\pi}{2} + \tan^{-1} \frac{\beta}{\omega} \right)$$

Total distance travelled in the first lap = l

To get the maximum displacement in the second lap we note that

$$\dot{x} = \left[-\beta \cos\left(\omega t - \tan^{-1} \frac{\beta}{\omega}\right) - \omega \sin\left(\omega t - \tan^{-1} \frac{\beta}{\omega}\right) \right]$$

$$x \frac{l\sqrt{\omega^2 + \beta^2}}{\omega} e^{-\beta t} = 0$$

when

$$\omega t = \pi, 2\pi, 3\pi, \dots \text{ etc.}$$

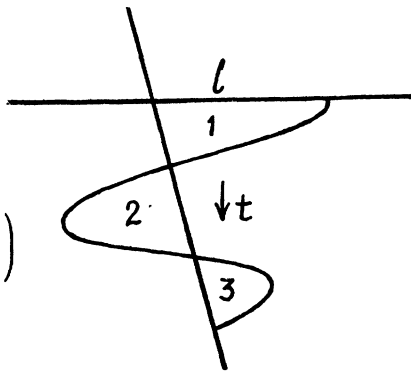

Thus $\dot{x}_{\max} = -a_0 e^{-\pi\beta/\omega} \cos \alpha = -l e^{-\pi\beta/\omega}$ for $t = \pi/\omega$

so, distance traversed in the 2nd lap = $2l e^{-\pi\beta/\omega}$

Continuing total distance traversed = $l + 2l e^{-\pi\beta/\omega} + 2l e^{-2\pi\beta/\omega} + \dots$

$$\begin{aligned} &= l + \frac{2l e^{-\pi\beta/\omega}}{1 - e^{-\beta\pi/\omega}} = l + \frac{2l}{e^{\beta\pi/\omega} - 1} \\ &= l \frac{e^{\beta\pi/\omega} + 1}{e^{\beta\pi/\omega} - 1} = l \frac{1 + e^{\lambda/2}}{e^{\lambda/2} - 1} \end{aligned}$$

where $\lambda = \frac{2\pi\beta}{\omega}$ is the logarithmic decrement. Substitution gives 2 metres.

4.77 For an undamped oscillator the mechanical energy $E = \frac{1}{2} m \dot{x}^2 + \frac{1}{2} m \omega_0^2 x^2$ is conserved. For a damped oscillator.

$$x = a_0 e^{-\beta t} \cos(\omega t + \alpha), \quad \omega = \sqrt{\omega_0^2 - \beta^2}$$

and

$$E(t) = \frac{1}{2} m \dot{x}^2 + \frac{1}{2} m \omega_0^2 x^2$$

$$\begin{aligned} &= \frac{1}{2} m a_0^2 e^{-2\beta t} \left[\beta^2 \cos^2(\omega t + \alpha) + 2\beta\omega \cos(\omega t + \alpha) \times \sin(\omega t + \alpha) + \omega^2 \sin^2(\omega t + \alpha) \right] \\ &\quad + \frac{1}{2} m a_0^2 \omega_0^2 e^{-2\beta t} \cos^2(\omega t + \alpha) \\ &= \frac{1}{2} m a_0^2 \omega_0^2 e^{-2\beta t} + \frac{1}{2} m a_0^2 \beta^2 e^{-2\beta t} \cos(2\omega t + 2\alpha) + \frac{1}{2} m a_0^2 \beta \omega e^{-2\beta t} \sin(2\omega t + 2\alpha) \end{aligned}$$

If $\beta \ll \omega$, then the average of the last two terms over many oscillations about the time t will vanish and

$$\langle E(t) \rangle = \frac{1}{2} m a_0^2 \omega_0^2 e^{-2\beta t}$$

and this is the relevant mechanical energy.

In time τ this decreases by a factor $\frac{1}{\eta}$ so

$$e^{-2\beta\tau} = \frac{1}{\eta} \quad \text{or} \quad \tau = \frac{\ln \eta}{2\beta}$$

$$\beta = \frac{\ln \eta}{2\tau}$$

$$\text{and} \quad \lambda = \frac{2\pi\beta}{\sqrt{\omega_0^2 - \beta^2}} = \frac{2\pi}{\sqrt{\left(\frac{\omega_0}{\beta}\right)^2 - 1}} = \frac{2\pi}{\sqrt{\frac{4g\tau^2}{l \ln^2 \eta} - 1}} \quad \text{since} \quad \omega_0^2 = \frac{g}{l}$$

$$\text{and} \quad Q = \frac{\pi}{\lambda} = \frac{1}{2} \sqrt{\frac{4g\tau^2}{l \ln^2 \eta} - 1} = 130.$$

4.78 The restoring couple is

$$\Gamma = -mgR \sin \varphi \approx -mgR \varphi$$

The moment of inertia is

$$I = \frac{3mR^2}{2}$$

Thus for undamped oscillations

$$\frac{3mR^2}{2} \ddot{\varphi} + mgR \varphi = 0$$

so, $\omega_0^2 = \frac{2g}{3R}$

Also $\lambda = \frac{2\pi\beta}{\omega} = \frac{2\pi\beta}{\sqrt{\omega_0^2 - \beta^2}}$

Hence $\frac{\beta}{\sqrt{\omega_0^2 - \beta^2}} = \frac{\lambda}{2\pi}$ or $\frac{\omega_0}{\sqrt{\omega_0^2 - \beta^2}} = \sqrt{1 + \left(\frac{\lambda}{2\pi}\right)^2}$

Hence finally the period T of small oscillation comes to

$$\begin{aligned} T &= \frac{2\pi}{\omega} = \frac{2\pi}{\omega_0} \times \frac{\omega_0}{\sqrt{\omega_0^2 - \beta^2}} = 2\pi \sqrt{\frac{3R}{2g} \left(1 + \left(\frac{\lambda}{2\pi}\right)^2\right)} \\ &= \sqrt{\frac{3R}{2g} (4\pi^2 + \lambda^2)} = 0.90 \text{ sec.} \end{aligned}$$

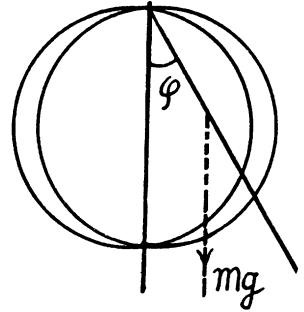

4.79 Let us calculate the moment G_1 of all the resistive forces on the disc. When the disc rotates an element $(r dr d\theta)$ with coordinates (r, θ) has a velocity $r\dot{\varphi}$, where φ is the instantaneous angle of rotation from the equilibrium position and r is measured from the centre. Then

$$\begin{aligned} G_1 &= \int_0^{2\pi} d\theta \int_0^R dr \cdot r \cdot (F_1 \times r) \\ &= \int_0^R \eta r \dot{\varphi} r^2 d\gamma \times 2\pi = \frac{\eta \pi R^4}{2} \dot{\varphi} \end{aligned}$$

Also moment of inertia = $\frac{mR^2}{2}$

Thus $\frac{mR^2}{2} \ddot{\varphi} + \frac{\pi \eta R^4}{2} \dot{\varphi} + \alpha \varphi = 0$

or $\ddot{\varphi} + 2 \frac{\pi \eta R^2}{2m} \dot{\varphi} + \frac{2\alpha}{mR^2} \varphi = 0$

Hence $\omega_0^2 = \frac{2\alpha}{mR^2}$ and $\beta = \frac{\pi \eta R^2}{2m}$

and angular frequency
$$\omega = \sqrt{\left(\frac{2\alpha}{mR^2}\right) - \left(\frac{\pi\eta R^2}{2m}\right)^2}$$

Note :- normally by frequency we mean $\frac{\omega}{2\pi}$.

4.80 From the law of viscosity, force per unit area = $\eta \frac{dv}{dx}$

so when the disc executes torsional oscillations the resistive couple on it is

$$= \int_0^R \eta \cdot 2\pi r \cdot \frac{r\varphi}{h} \cdot r \cdot dr \times 2 = \frac{\eta \pi R^4}{h} \dot{\varphi}$$

(factor 2 for the two sides of the disc; see the figure in the book)

where φ is torsion. The equation of motion is

$$I \ddot{\varphi} + \frac{\eta \pi R^4}{h} \dot{\varphi} + c \varphi = 0$$

Comparing with $\ddot{\varphi} + 2\beta \dot{\varphi} + \omega_0^2 \varphi = 0$ we get

$$\beta = \eta \pi R^4 / 2hI$$

Now the logarithmic decrement λ is given by $\lambda = \beta T$, T = time period

Thus

$$\eta = 2\lambda hI / \pi R^4 T$$

4.81 If φ = angle of deviation of the frame from its normal position, then an e.m.f.

$$\varepsilon = B a^2 \dot{\varphi}$$

is induced in the frame in the displaced position and a current $\frac{\varepsilon}{R} = \frac{B a^2 \dot{\varphi}}{R}$ flows in it. A couple

$$\frac{B a^2 \dot{\varphi}}{R} \cdot B \cdot a \cdot a = \frac{B^2 a^4}{R} \dot{\varphi}$$

then acts on the frame in addition to any elastic restoring couple $c \varphi$. We write the equation of the frame as

$$I \ddot{\varphi} + \frac{B^2 a^4}{R} \dot{\varphi} + c \varphi = 0$$

Thus $\beta = \frac{B^2 a^4}{2IR}$ where β is defined in the book.

Amplitude of oscillation die out according to $e^{-\beta t}$ so time required for the oscillations to decrease to $\frac{1}{e}$ of its value is

$$\frac{1}{\beta} = \frac{2IR}{B^2 a^4}$$

4.82 We shall denote the stiffness constant by κ . Suppose the spring is stretched by x_0 . The bar is then subject to two horizontal forces (1) restoring force $-\kappa x$ and (2) friction kmg opposing motion. If

$$x_0 > \frac{kmg}{\kappa} = \Delta$$

the bar will come back.

(If $x_0 \leq \Delta$, the bar will stay put.)

The equation of the bar when it is moving to the left is

$$m \ddot{x} = -\kappa x + kmg$$

This equation has the solution

$$x = \Delta + (x_0 - \Delta) \cos \sqrt{\frac{\kappa}{m}} t$$

where we have used $x = x_0, \dot{x} = 0$ at $t = 0$. This solution is only valid till the bar comes to rest. This happens at

$$t_1 = \pi / \sqrt{\frac{\kappa}{m}}$$

and at that time $x = x_1 = 2\Delta - x_0$. if $x_0 > 2\Delta$ the tendency of the rod will now be to move to the right. (if $\Delta < x_0 < 2\Delta$ the rod will stay put now) Now the equation for rightward motion becomes

$$m \ddot{x} = -\kappa x - kmg$$

(the friction force has reversed).

We notice that the rod will move to the right only if

$$\kappa(x_0 - 2\Delta) > kmg \quad \text{i.e. } x_0 > 3\Delta$$

In this case the solution is

$$x = -\Delta + (x_0 - 3\Delta) \cos \sqrt{\frac{\kappa}{m}} t$$

Since $x = 2\Delta - x_0$ and $\dot{x} = 0$ at $t = t_1 = \pi / \sqrt{\frac{\kappa}{m}}$.

The rod will next come to rest at

$$t = t_2 = 2\pi / \sqrt{\frac{\kappa}{m}}$$

and at that instant $x = x_2 = x_0 - 4\Delta$. However the rod will stay put unless $x_0 > 5\Delta$.

Thus

(a) time period of one full oscillation = $2\pi / \sqrt{\frac{\kappa}{m}}$.

(b) There is no oscillation if $0 < x_0 < \Delta$

One half oscillation if $\Delta < x_0 < 3\Delta$

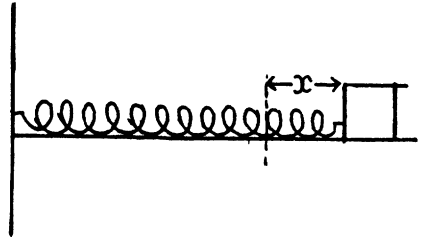

2 half oscillation if $3 \Delta < x_0 < 5 \Delta$ etc.

We can say that the number of full oscillations is one half of the integer n

where
$$n = \left[\frac{x_0 - \Delta}{2 \Delta} \right]$$

where $[x] =$ smallest non-negative integer greater than x .

4.83 The equation of motion of the ball is

$$m(\ddot{x} + \omega_0^2 x) = F_0 \cos \omega t$$

This equation has the solution

$$x = A \cos(\omega_0 t + \alpha) + B \cos \omega t$$

where A and α are arbitrary and B is obtained by substitution in the above equation

$$B = \frac{F_0/m}{\omega_0^2 - \omega^2}$$

The conditions $x = 0, \dot{x} = 0$ at $t = 0$ give

$$A \cos \alpha + \frac{F_0/m}{\omega_0^2 - \omega^2} = 0 \quad \text{and} \quad -\omega_0 A \sin \alpha = 0$$

This gives $\alpha = 0,$

$$A = -\frac{F_0/m}{\omega_0^2 - \omega^2} = \frac{F_0/m}{\omega^2 - \omega_0^2}$$

Finally,

$$x = \frac{F_0/m}{\omega^2 - \omega_0^2} (\cos \omega_0 t - \cos \omega t)$$

4.84 We have to look for solutions of the equation

$$m\ddot{x} + kx = F, \quad 0 < t_1 < \tau,$$

$$m\ddot{x} + kx = 0, \quad t > \tau$$

subject to $x(0) = \dot{x}(0) = 0$ where F is constant.

The solution of this equation will be sought in the form

$$x = \frac{F}{k} + A \cos(\omega_0 t + \alpha), \quad 0 \leq t \leq \tau$$

$$x = B \cos(\omega_0(t - \tau) + \beta), \quad t > \tau$$

A and α will be determined from the boundary condition at $t = 0$.

$$0 = \frac{F}{k} + A \cos \alpha$$

$$0 = -\omega_0 A \sin \alpha$$

Thus $\alpha = 0$ and $A = -\frac{F}{k}$ and $x = \frac{F}{k}(1 - \cos \omega_0 t)$ $0 \leq t < \tau$.

B and β will be determined by the continuity of x and \dot{x} at $t = \tau$. Thus

$$\frac{F}{k}(1 - \cos \omega_0 \tau) = B \cos \beta \quad \text{and} \quad \phi_0 \frac{F}{k} \sin \omega_0 \tau = -\phi_0 B \sin \beta$$

Thus
$$B^2 = \left(\frac{F}{k}\right)^2 (2 - 2 \cos \omega_0 \tau)$$

or
$$B = 2 \frac{F}{k} \left| \sin \frac{\omega_0 \tau}{2} \right|$$

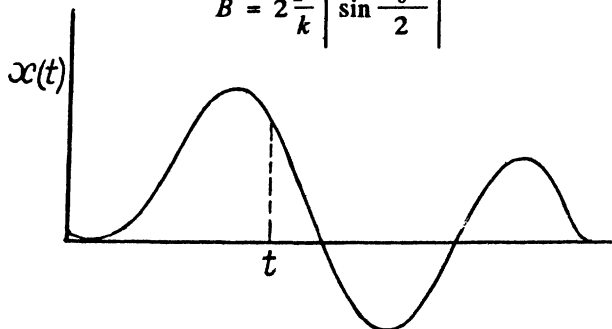

4.85 For the spring $mg = \kappa \Delta l$ where κ is its stiffness coefficient. Thus

$$\omega_0^2 = \frac{\kappa}{m} = \frac{g}{\Delta l},$$

The equation of motion of the ball is

$$\ddot{x} + 2\beta \dot{x} + \omega_0^2 x = \frac{F_0}{m} \cos \omega t$$

Here
$$\lambda = \frac{2\pi\beta}{\sqrt{\omega_0^2 - \beta^2}} \quad \text{or} \quad \frac{\beta}{\omega} = \frac{\lambda/2\pi}{\sqrt{1 + (\lambda/2\pi)^2}}$$

To find the solution of the above equation we look for the solution of the auxiliary equation

$$\ddot{z} + 2\beta \dot{z} + \omega_0^2 z = \frac{F_0}{m} e^{i\omega t}$$

Clearly we can take $\text{Re } z = x$. Now we look for a particular integral for z of the form

$$z = A e^{i\omega t}$$

Thus, substitution gives A and we get

$$z = \frac{(F_0/m) e^{i\omega t}}{\omega_0^2 - \omega^2 + 2i\beta\omega}$$

so taking the real part

$$\begin{aligned} x &= \frac{(F_0/m) [(\omega_0^2 - \omega^2) \cos \omega t + 2\beta\omega \sin \omega t]}{(\omega_0^2 - \omega^2)^2 + 4\beta^2\omega^2} \\ &= \frac{F_0}{m} \frac{\cos(\omega t - \varphi)}{\sqrt{(\omega_0^2 - \omega^2)^2 + 4\beta^2\omega^2}}, \quad \varphi = \tan^{-1} \frac{2\beta\omega}{\omega_0^2 - \omega^2} \end{aligned}$$

The amplitude of this oscillation is maximum when the denominator is minimum.

This happens when

$\omega^4 - 2\omega_0^2\omega^2 + 4\beta^2\omega^2 + \omega_0^4 = (\omega^2 - \omega_0^2 + 2\beta^2) + 4\beta^2\omega_0^2 - 4\beta^4$ is minimum. i.e. for $\omega^2 = \omega_0^2 - 2\beta^2$

Thus

$$\omega_{res}^2 = \omega_0^2 \left(1 - \frac{2\beta^2}{\omega_0^2} \right)$$

$$= \frac{g}{\Delta l} \left[1 - \frac{2 \left(\frac{\lambda}{2\pi} \right)^2}{1 + \left(\frac{\lambda}{2\pi} \right)^2} \right] = \frac{g}{\Delta l} \frac{1 - \left(\frac{\lambda}{2\pi} \right)^2}{1 + \left(\frac{\lambda}{2\pi} \right)^2}$$

and

$$a_{res} = \frac{F_0/m}{\sqrt{4\beta^2\omega_0^2 - 4\beta^4}} = \frac{F_0/m}{2\beta\sqrt{\omega_0^2 - \beta^2}} = \frac{F_0/m}{2\beta^2} \cdot \frac{\lambda}{2\pi}$$

$$= \frac{F_0}{2m\omega_0^2} \cdot \frac{1 + \left(\frac{\lambda}{2\pi} \right)^2}{\lambda/2\pi} = \frac{F_0 \Delta l \lambda}{4\pi m g} \left(1 + \frac{4\pi^2}{\lambda^2} \right)$$

4.86 Since $a = \frac{F_0/m}{\sqrt{(\omega^2 - \omega_0^2 + 2\beta^2)^2 + 4\beta^2(\omega_0^2 - \beta^2)}}$

we must have $\omega_1^2 - \omega_0^2 + 2\beta^2 = -(\omega_2^2 - \omega_0^2 + 2\beta^2)$

or $\omega_0^2 - 2\beta^2 = \frac{\omega_1^2 + \omega_2^2}{2} = \omega_{res}^2$

4.87 $x = \frac{F_0}{m} \frac{(\omega_0^2 - \omega^2) \cos \omega t + 2\beta \omega \sin \omega t}{\sqrt{(\omega^2 - \omega_0^2)^2 + 4\beta^2 \omega^2}}$

Then $\dot{x} = \frac{F_0 \omega}{m} \frac{2\beta \omega \cos \omega t + (\omega^2 - \omega_0^2) \sin \omega t}{(\omega_0^2 - \omega^2)^2 + 4\beta^2 \omega^2}$

Thus the velocity amplitude is

$$V_0 = \frac{F_0 \omega}{m \sqrt{(\omega_0^2 - \omega^2)^2 + 4\beta^2 \omega^2}}$$

$$= \frac{F_0}{m \sqrt{\left(\frac{\omega_0^2}{\omega} - \omega \right)^2 + 4\beta^2}}$$

This is maximum when

$$\omega^2 = \omega_0^2 = \omega_{res}^2$$

and then

$$V_{0res} = \frac{F_0}{2m\beta}$$

Now at half maximum
$$\left(\frac{\omega_0^2}{\omega} - \omega \right)^2 = 12 \beta^2$$

or
$$\omega^2 \pm 2\sqrt{3} \beta \omega - \omega_0^2 = 0$$

$$\omega = + \beta \sqrt{3} + \sqrt{\omega_0^2 + 3 \beta^2}$$

where we have rejected a solution with -ve sign before there dicul. Writing

$$\omega_1 = \sqrt{\omega_0^2 + 3 \beta^2} + \beta \sqrt{3}, \quad \omega_2 = \sqrt{\omega_0^2 + 3 \beta^2} - \beta \sqrt{3}$$

we get (a) $\omega_{res} = \omega_0 = \sqrt{\omega_1 \omega_2}$ (Velocity resonance frequency)

(b) $\beta = \frac{|\omega_1 - \omega_2|}{2\sqrt{3}}$ and damped oscillation frequency

$$\sqrt{\omega_0^2 - \beta^2} = \sqrt{\omega_1 \omega_2 - \frac{(\omega_1 - \omega_2)^2}{12}}$$

4.88 In general for displacement amplitude

$$a = \frac{F_0}{m} \frac{1}{\sqrt{(\omega_0^2 - \omega^2)^2 + 4 \beta^2 \omega^2}}$$

$$= \frac{F_0}{m} \frac{1}{\sqrt{(\omega^2 - \omega_0^2 + 2 \beta^2)^2 + 4 \beta^2 (\omega_0^2 - \beta^2)}}$$

Thus
$$\eta = \frac{a_{res}}{a_{low}} = \frac{\omega_0^2}{\sqrt{4 \beta^2 (\omega_0^2 - \beta^2)}} = \frac{\omega_0^2}{2 \beta \sqrt{\omega_0^2 - \beta^2}}$$

But
$$\frac{\beta}{\omega_0} = \frac{\lambda/2\pi}{\sqrt{1 + (\lambda/2\pi)^2}}, \quad \frac{\lambda}{2\pi} = \frac{\beta}{\sqrt{\omega_0^2 - \beta^2}}$$

Hence
$$\eta = \frac{\omega_0^2}{2 \beta^2} \cdot \frac{\lambda}{2\pi} = \frac{1}{2} \frac{1 + \left(\frac{\lambda}{2\pi} \right)^2}{\frac{\lambda}{2\pi}} = 2.90$$

4.89 The work done in one cycle is

$$A = \int_0^T F dx = \int_0^T F v dt = \int_0^T F_0 \cos \omega t (-\omega a \sin(\omega t - \phi)) dt$$

$$= \int_0^T F_0 \omega a (-\cos \omega t \sin \omega t \cos \phi + \cos^2 \omega t \sin \phi) dt$$

$$= \frac{1}{2} F_0 \omega a \frac{T}{2} \sin \phi = \pi a F_0 \sin \phi$$

4.90 In the formula $x = a \cos(\omega t - \varphi)$

we have

$$a = \frac{F_0}{m} \frac{1}{\sqrt{(\omega_0^2 - \omega^2)^2 + 4\beta^2 \omega^2}}$$

$$\tan \varphi = \frac{2\beta\omega}{\omega_0^2 - \omega^2}$$

Thus

$$\beta = \frac{(\omega_0^2 - \omega^2) \tan \varphi}{2\omega}$$

Hence

$$\omega_0 = \sqrt{K/m} = 20 \text{ s}^{-1}$$

and (a) the quality factor

$$Q = \frac{\pi}{\beta T} = \frac{\sqrt{\omega_0^2 - \beta^2}}{2\beta} = \frac{1}{2} \sqrt{\frac{4\omega^2 \omega_0^2}{(\omega_0^2 - \omega^2)^2 \tan^2 \varphi} - 1} = 2.17$$

(b) work done is $A = \pi a F_0 \sin \varphi$

$$\begin{aligned} &= \pi m a^2 \sqrt{(\omega_0^2 - \omega^2)^2 + 4\beta^2 \omega^2} \sin \varphi = \pi m a^2 \times 2\beta \omega \\ &= \pi m a^2 (\omega_0^2 - \omega^2) \tan \varphi = 6 \text{ mJ} \end{aligned}$$

4.91 Here as usual $\tan \varphi = \frac{2\beta\omega}{\omega_0^2 - \omega^2}$ where φ is the phase lag of the displacement

$$x = a \cos(\omega t - \varphi), \quad a = \frac{F_0}{m} \frac{1}{\sqrt{(\omega_0^2 - \omega^2)^2 + 4\beta^2 \omega^2}}$$

(a) Mean power developed by the force over one oscillation period

$$\begin{aligned} &= \frac{\pi F_0 a \sin \varphi}{T} = \frac{1}{2} F_0 a \omega \sin \varphi \\ &= \frac{F_0^2}{m} \frac{\beta \omega^2}{(\omega_0^2 - \omega^2)^2 + 4\beta^2 \omega^2} = \frac{F_0^2 \beta}{m} \frac{1}{\left(\frac{\omega_0^2}{\omega} - \omega\right)^2 + 4\beta^2} \end{aligned}$$

(b) Mean power $\langle P \rangle$ is maximum when $\omega = \omega_0$ (for the denominator is then minimum)

Also

$$\langle P \rangle_{\max} = \frac{F_0^2}{4m\beta}$$

4.92 Given $\beta = \omega_0/\eta$. Then from the previous problem

$$\langle P \rangle = \frac{F_0^2 \omega_0}{\eta m} \cdot \frac{1}{\left(\frac{\omega_0^2}{\omega} - \omega\right)^2 + 4\frac{\omega_0^2}{\eta^2}}$$

At displacement resonance $\omega = \sqrt{\omega_0^2 - 2\beta^2}$

$$\begin{aligned} \langle P \rangle_{res} &= \frac{F_0^2 \omega_0}{\eta m} \frac{1}{\frac{4\beta^4}{\omega_0^2 - 2\beta^2} + \frac{4\omega_0^2}{\eta^2}} = \frac{F_0^2 \omega_0}{\eta m} \frac{1}{\frac{4\omega_0^4/\eta^4}{\omega_0^2 \left(1 - \frac{2}{\eta^2}\right)} + 4\frac{\omega_0^2}{\eta^2}} \\ &= \frac{F_0^2}{4\eta m \omega_0} \frac{\eta^2}{\frac{1}{\eta^2 - 2} + 1} = \frac{F_0^2 \eta}{4m \omega_0} \frac{\eta^2 - 2}{\eta^2 - 1} \end{aligned}$$

while $\langle P \rangle_{max} = \frac{F_0^2 \eta}{4m \omega_0}$.

Thus $\frac{\langle P \rangle_{max} - \langle P \rangle_{res}}{\langle P \rangle_{max}} = \frac{100}{\eta^2 - 1} \%$

4.93 The equation of the disc is $\ddot{\varphi} + 2\beta\dot{\varphi} + \omega_0^2\varphi = \frac{N_m \cos \omega t}{I}$

Then as before $\varphi = \varphi_m \cos(\omega t - \alpha)$

where $\varphi_m = \frac{N_m}{I[(\omega_0^2 - \omega^2)^2 + 4\beta^2\omega^2]^{1/2}}$, $\tan \alpha = \frac{2\beta\omega}{\omega_0^2 - \omega^2}$

(a) Work performed by frictional forces

$$\begin{aligned} &= -\int N_r d\varphi \quad \text{where } N_r = -2I\beta\dot{\varphi} = -\int_0^T 2\beta I \dot{\varphi}^2 dt = -2\pi\beta\omega I \varphi_m^2 \\ &= -\pi I \varphi_m^2 [(\omega_0^2 - \omega^2)^2 + 4\beta^2\omega^2]^{1/2} \sin \alpha = -\pi N_m \varphi_m \sin \alpha \end{aligned}$$

(b) The quality factor

$$\begin{aligned} Q &= \frac{\pi}{\lambda} = \frac{\pi}{\beta T} = \frac{\sqrt{\omega_0^2 - \beta^2}}{2\beta} = \frac{\omega \sqrt{\omega_0^2 - \beta^2}}{(\omega_0^2 - \omega^2) \tan \alpha} = \frac{1}{2 \tan \alpha} \left\{ \frac{4\omega^2 \omega_0^2}{(\omega_0^2 - \omega^2)^2} - \frac{4\beta^2 \omega^2}{(\omega_0^2 - \omega^2)^2} \right\}^{1/2} \\ &= \frac{1}{2 \tan \alpha} \left\{ \frac{4\omega^2 \omega_0^2 I^2 \varphi_m^2}{N_m^2 \cos^2 \alpha} - \tan^2 \alpha \right\}^{1/2} \quad \text{since } \omega_0^2 = \omega^2 + \frac{N_m}{I \varphi_m} \cos \alpha \\ &= \frac{1}{2 \sin \alpha} \left\{ \frac{4\omega^2 \omega_0^2 I^2 \varphi_m^2}{N_m^2} - \sin^2 \alpha \right\}^{1/2} \\ &= \frac{1}{2 \sin \alpha} \left\{ \frac{4\omega^2 I^2 \varphi_m^2}{N_m^2} \left(\omega^2 + \frac{N_m \cos \alpha}{I \varphi_m} \right) + 1 - \cos^2 \alpha \right\}^{1/2} \\ &= \frac{1}{2 \sin \alpha} \left\{ \frac{4I^2 \varphi_m^2}{N_m^2} \omega^4 + \frac{4I \varphi_m}{N_m} \omega^2 \cos \alpha + \cos^2 \alpha - 1 \right\}^{1/2} = \frac{1}{2 \sin \alpha} \left\{ \left(\frac{2I \varphi_m \omega^2}{N_m} + \cos \alpha \right)^2 - 1 \right\}^{1/2} \end{aligned}$$

4.2 ELECTRIC OSCILLATIONS

4.94 If the electron (charge of each electron = $-e$) are shifted by a small distance x , a net +ve charge density (per unit area) is induced on the surface. This will result in an electric field $E = n e x / \epsilon_0$ in the direction of x and a restoring force on an electron of

$$- \frac{n e^2 x}{\epsilon_0},$$

Thus
$$m \ddot{x} = - \frac{n e^2 x}{\epsilon_0}$$

or
$$\ddot{x} + \frac{n e^2}{m \epsilon_0} x = 0$$

This gives
$$\omega_p = \sqrt{\frac{n e^2}{m \epsilon_0}} = 1.645 \times 10^{16} \text{ s}^{-1}.$$

as the plasma frequency for the problem.

4.95 Since there are no sources of emf in the circuit, Ohm's 1 law reads

$$\frac{q}{C} = -L \frac{dI}{dt}$$

where q = charge on the capacitor, $I = \frac{dq}{dt}$ = current through the coil. Then

$$\frac{d^2 q}{dt^2} + \omega_0^2 q = 0, \quad \omega_0^2 = \frac{1}{LC}.$$

The solution fo this equation is

$$q = q_m \cos(\omega_0 t + \alpha)$$

From the problem $V_m = \frac{q_m}{C}$. Then

$$I = -\omega_0 C V_m \sin(\omega_0 t + \alpha)$$

and

$$V = V_m \cos(\omega_0 t - \alpha)$$

$$V^2 + \frac{I^2}{\omega_0^2 C^2} = V_m^2$$

or

$$V^2 + \frac{L I^2}{C} = V_m^2.$$

By energy conservation
$$\frac{1}{2} L I^2 + \frac{q^2}{2C} = \text{constant}$$

When the P.D. across the capacitor takes its maximum value V_m , the current I must be zero.

Thus "constant" = $\frac{1}{2} C V_m^2$

Hence
$$\frac{L I^2}{C} + V^2 = V_m^2 \text{ once again.}$$

4.96 After the switch was closed, the circuit satisfies

$$-L \frac{dI}{dt} = \frac{q}{C}$$

or
$$\frac{d^2 q}{dt^2} + \omega_0^2 q = 0 \Rightarrow q = C V_m \cos \omega_0 t$$

where we have used the fact that when the switch is closed we must have

$$V = \frac{q}{C} = V_m, \quad I = \frac{dq}{dt} = 0 \text{ at } t = 0.$$

Thus (a)

$$\begin{aligned} I &= \frac{dq}{dt} = -C V_m \omega_0 \sin \omega_0 t \\ &= -V_m \sqrt{\frac{C}{L}} \sin \omega_0 t \end{aligned}$$

(b) The electrical energy of the capacitor is $\frac{q^2}{2C} \propto \cos^2 \omega_0 t$ and of the inductor is

$$\frac{1}{2} L I^2 \propto \sin^2 \omega_0 t.$$

The two are equal when

$$\omega_0 t = \frac{\pi}{4}$$

At that instant the emf of the self-inductance is

$$-L \frac{di}{dt} = V_m \cos \omega_0 t = V_m / \sqrt{2}$$

4.97 In the oscillating circuit, let

$$q = q_m \cos \omega t$$

be the charge on the condenser where

$\omega^2 = \frac{1}{LC}$ and C is the instantaneous capacity of the condenser (S = area of plates)

$$C = \frac{\epsilon_0 S}{y}$$

y = distance between the plates. Since the oscillation frequency increases η fold, the quantity

$$\omega^2 = \frac{y}{\epsilon_0 S L}$$

changes η^2 fold and so does y i.e. changes from y_0 initially to $\eta^2 y_0$ finally. Now the P.D. across the condenser is

$$V = \frac{q_m}{C} \cos \omega t = \frac{y q_m}{\epsilon_0 S} \cos \omega t$$

and hence the electric field between the plates is

$$E = \frac{q_m}{\epsilon_0 S} \cos \omega t$$

Thus, the charge on the plate being $q_m \cos \omega t$, the force on the plate is

$$F = \frac{q_m^2}{\epsilon_0 S} \cos^2 \omega t$$

Since this force is always positive and the plate is pulled slowly we can use the average force

$$\bar{F} = \frac{q_m^2}{2 \epsilon_0 S}$$

and work done is $A = \bar{F} (\eta^2 y_0 - y_0) = (\eta^2 - 1) \frac{q_m^2 y_0}{2 \epsilon_0 S}$

But $\frac{q_m^2 y_0}{2 \epsilon_0 S} = \frac{q_m^2}{2 C_0} = W$ the initial stored energy. Thus.

$$A = (\eta^2 - 1) W.$$

4.98 The equations of the $L - C$ circuit are

$$L \frac{d}{dt} (I_1 + I_2) = \frac{C_1 V - \int I_1 dt}{C_1} = \frac{C_2 V - \int I_2 dt}{C_2}$$

Differentiating again $L (I_1 + I_2) = -\frac{1}{C_1} I_1 = -\frac{1}{C_2} I_2$

Then $I_1 = \frac{C_1}{C_1 - C_2} I$, $I_2 = \frac{C_2}{C_1 + C_2} I$,
 $I = I_1 + I_2$

so $L (C_1 + C_2) I + I = 0$

or $I = I_0 \sin (\omega_0 t + \alpha)$

where $\omega_0^2 = \frac{1}{L (C_1 + C_2)}$ (Part a)

(Hence $T = \frac{2\pi}{\omega_0} = 0.7$ ms)

At $t = 0$, $I = 0$ so $\alpha = 0$

$$I = I_0 \sin \omega_0 t$$

The peak value of the current is I_0 and it is related to the voltage V by the first equation

$$L I = V - \int I dt / (C_1 + C_2)$$

or $+L \omega_0 I_0 \cos \omega_0 t = V - \frac{1}{C_1 + C_2} \int_0^t I_0 \sin \omega_0 t dt$

(The P.D. across the inductance is V at $t = 0$)

$$= V + \frac{1}{C_1 + C_2} \cdot \frac{I_0}{\omega_0} (\cos \omega_0 t - 1)$$

Hence $I_0 = (C_1 + C_2) \omega_0 V = V \sqrt{\frac{C_1 + C_2}{L}} = 8.05$ A.

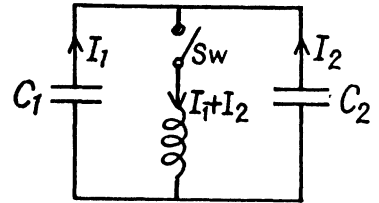

4.99 Initially $q_1 = C V_0$ and $q_2 = 0$. After the switch is closed charge flows and we get

$$q_1 + q_2 = C V_0$$

$$\frac{q_1}{C} + L \frac{dI}{dt} - \frac{q_2}{C} = 0 \quad (1)$$

Also $I = \dot{q}_1 = -\dot{q}_2$. Thus

$$L \ddot{I} + \frac{2I}{C} = 0$$

$$\text{Hence } \ddot{I} + \omega_0^2 I = 0 \quad \omega_0^2 = \frac{2}{LC},$$

The solution of this equation subject to

$$I = 0 \text{ at } t = 0$$

$$\text{is } I = I_0 \sin \omega_0 t.$$

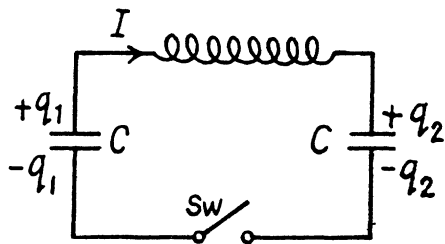

Integrating

$$q_1 = A - \frac{I_0}{\omega_0} \cos \omega_0 t$$

$$q_2 = B + \frac{I_0}{\omega_0} \cos \omega_0 t$$

Finally substituting in (1)

$$\frac{A-B}{C} - \frac{2I_0}{\omega_0 C} \cos \omega_0 t + L I_0 \omega_0 \cos \omega_0 t = 0$$

Thus

$$A = B = \frac{C V_0}{2} \text{ and}$$

$$\frac{C V_0}{2} + \frac{I_0}{\omega_0} = 0$$

so

$$q_1 = \frac{C V_0}{2} (1 + \cos \omega_0 t)$$

$$q_2 = \frac{C V_0}{2} (1 - \cos \omega_0 t)$$

4.100 The flux in the coil is

$$\Phi(t) = \begin{cases} \Phi & t < 0 \\ 0 & t > 0 \end{cases}$$

The equation of the current is

$$-L \frac{dI}{dt} = \frac{\int I dt}{C} \quad (1)$$

This means that

$$LC \frac{d^2 I}{dt^2} + I = 0$$

$$\text{or with } \omega_0^2 = \frac{1}{LC}$$

$$I = I_0 \sin(\omega_0 t + \alpha)$$

Putting in (1) $-L I_0 \omega_0 \cos(\omega_0 t + \alpha) = -\frac{I_0}{\omega_0 C} [\cos(\omega_0 t + \alpha) - \cos \alpha]$

This implies $\cos \alpha = 0 \therefore I = \pm I_0 \cos \omega_0 t$. From Faraday's law

$$\varepsilon = -\frac{d\Phi}{dt} = -L \frac{dI}{dt}$$

or integrating from $t = -\varepsilon$ to $-\varepsilon$ where $\varepsilon \rightarrow 0$

$$\Phi = L I_0 \text{ with } + \text{ sign in } I$$

so,
$$I = \frac{\Phi}{L} \cos \omega_0 t.$$

4.101 Given $V = V_m e^{-\beta t} \cos \omega t$

(a) The phrase 'peak values' is not clear. The answer is obtained on taking $|\cos \omega t| = 1$

i.e.
$$t = \frac{\pi n}{\omega}.$$

(b) For extrema $\frac{dV}{dt} = 0$

$$-\beta \cos \omega t - \omega \sin \omega t = 0$$

or
$$\tan \omega t = -\beta/\omega$$

i.e.
$$\omega t = n\pi + \tan^{-1}\left(\frac{-\beta}{\omega}\right).$$

4.102 The equation of the circuit is

$$L \frac{d^2 Q}{dt^2} + R \frac{dQ}{dt} + \frac{Q}{C} = 0$$

where Q = charge on the capacitor,

This has the solution $Q = Q_m e^{-\beta t} \sin(\omega t + \alpha)$

where $\beta = \frac{R}{2L}$, $\omega = \sqrt{\omega_0^2 - \beta^2}$, $\omega_0^2 = \frac{1}{LC}$.

Now
$$I = \frac{dQ}{dt} = 0 \text{ at } t = 0$$

so, $Q_m e^{-\beta t} (-\beta \sin(\omega t + \alpha) + \omega \cos(\omega t + \alpha)) = 0$ at $t = 0$

Thus $\omega \cos \alpha = \beta \sin \alpha$ or $\alpha = \tan^{-1} \frac{\omega}{\beta}$

Now $V_m = \frac{Q_m}{C}$ and $V_0 = \text{P.D. at } t = 0 = \frac{Q_m}{C} \sin \alpha$

$$\therefore \frac{V_0}{V_m} = \sin \alpha = \frac{\omega}{\sqrt{\omega^2 + \beta^2}} = \frac{\omega}{\omega_0} = \sqrt{1 - \beta^2/\omega_0^2} = \sqrt{1 - \frac{R^2 C}{4L^2}}$$

4.103 We write

$$\begin{aligned} -\frac{dQ}{dt} &= I = I_m e^{-\beta t} \sin \omega t \\ &= gm I_m e^{-\beta t + i\omega t} \quad (gm \text{ means imaginary part}) \end{aligned}$$

Then

$$\begin{aligned} Q &= gm I_m \frac{e^{-\beta t + i\omega t}}{-\beta + i\omega} \\ Q &= gm I_m \frac{e^{-\beta t + i\omega t}}{\beta - i\omega} \\ &= gm I_m \frac{(\beta + i\omega) e^{-\beta t + i\omega t}}{\beta^2 + \omega^2} \\ &= I_m e^{-\beta t} \frac{\beta \sin \omega t + \omega \cos \omega t}{\beta^2 + \omega^2} \\ &= I_m e^{-\beta t} \frac{\sin(\omega t + \delta)}{\sqrt{\beta^2 + \omega^2}}, \quad \tan \delta = \frac{\omega}{\beta}. \end{aligned}$$

(An arbitrary constant of integration has been put equal to zero.)

Thus

$$\begin{aligned} V &= \frac{Q}{C} = I_m \sqrt{\frac{L}{C}} e^{-\beta t} \sin(\omega t + \delta) \\ V(0) &= I_m \sqrt{\frac{L}{C}} \sin \delta = I_m \sqrt{\frac{L}{C}} \frac{\omega}{\sqrt{\omega^2 + \beta^2}} \\ &= I_m \sqrt{\frac{L}{C(1 + \beta^2/\omega^2)}}. \end{aligned}$$

4.104 $I = I_m e^{-\beta t} \sin \omega t$

$$\beta = \frac{R}{2L}, \quad \omega_0 = \sqrt{\frac{1}{LC}}, \quad \omega = \sqrt{\omega_0^2 - \beta^2}$$

$I = -\dot{q}$, q = charge on the capacitor

Then
$$q = I_m e^{-\beta t} \frac{\sin(\omega t + \delta)}{\sqrt{\omega^2 + \beta^2}}, \quad \tan \delta = \frac{\omega}{\beta}.$$

Thus

$$\begin{aligned} W_M &= \frac{1}{2} L I_m^2 e^{-2\beta t} \sin^2 \omega t \\ W_E &= \frac{I_m^2}{2C} \frac{e^{-2\beta t} \sin^2(\omega t + \delta)}{\omega^2 + \beta^2} = \frac{L I_m^2}{2} e^{-2\beta t} \sin^2(\omega t + \delta) \end{aligned}$$

Current is maximum when $\frac{d}{dt} e^{-\beta t} \sin \omega t = 0$

Thus $-\beta \sin \omega t + \omega \cos \omega t = 0$

or $\tan \omega t = \frac{\omega}{\beta} = \tan \delta$

i.e. $\omega t = n\pi + \delta$

and hence
$$\frac{W_M}{W_E} = \frac{\sin^2(\omega t)}{\sin^2(\omega t + \delta)} = \frac{\sin^2 \delta}{\sin^2 2\delta} = \frac{1}{4 \cos^2 \delta}$$

$$= \frac{1}{4 \beta^2 / \omega_0^2} = \frac{\omega_0^2}{4 \beta^2} = \frac{1}{LC} \times \frac{L^2}{R^2} = \frac{L}{CR^2} = 5.$$

(W_M is the magnetic energy of the inductance coil and W_E is the electric energy of the capacitor.)

4.105 Clearly

$$L = L_1 + L_2, R = R_1 + R_2$$

4.106 $Q = \frac{\pi}{\beta T}$ or $\beta = \frac{\pi}{QT}$

Now $\beta t = \ln \eta$ so $t = \frac{\ln \eta}{\pi} QT$

$$= \frac{Q \ln \eta}{\pi \nu} = 0.5 \text{ ms}$$

4.107 Current decreases e fold in time

$$t = \frac{1}{\beta} = \frac{2L}{R} \text{ sec} = \frac{2L}{RT} \text{ oscillations}$$

$$= \frac{2L}{R} \frac{\omega}{2\pi}$$

$$= \frac{L}{\pi R} \sqrt{\frac{1}{LC} - \frac{R^2}{4L^2}} = \frac{1}{2\pi} \sqrt{\frac{4L}{R^2 C} - 1} = 15.9 \text{ oscillations}$$

4.108 $Q = \frac{\pi}{\beta T} = \frac{\omega}{2\beta}$

$$\therefore \omega = 2\beta Q, \beta = \frac{\omega}{2Q}$$

Now $\omega_0 = \omega \sqrt{1 + \frac{1}{4Q^2}}$ or $\omega = \frac{\omega_0}{\sqrt{1 + \frac{1}{4Q^2}}}$

so $\left| \frac{\omega_0 - \omega}{\omega_0} \right| \times 100\% = \frac{1}{8Q^2} \times 100\% = 0.5\%$

4.109

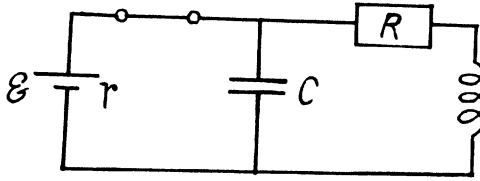

At $t = 0$ current through the coil = $\frac{\epsilon}{R + r}$

P.D. across the condenser = $\frac{\epsilon}{R + r}$

(a) At $t = 0$, energy stored = W_0

$$= \frac{1}{2} L \left(\frac{\epsilon}{R + r} \right)^2 + \frac{1}{2} C \left(\frac{\epsilon R}{R + r} \right)^2 = \frac{1}{2} \epsilon^2 \frac{(L + CR^2)}{(R + r)^2} = 2.0 \text{ mJ.}$$

(b) The current and the charge stored decrease as $e^{-tR/2L}$ so energy decreases as $e^{-tR/L}$
 $\therefore W = W_0 e^{-tR/L} = 0.10 \text{ mJ.}$

4.110 $Q = \frac{\pi}{\beta T} = \frac{\pi v}{\beta} = \frac{\omega}{2\beta} = \frac{\sqrt{\omega_0^2 - \beta^2}}{2\beta}$

or $\frac{\omega_0}{\beta} = \sqrt{1 + 4Q^2}$ or $\beta = \frac{\omega_0}{\sqrt{1 + 4Q^2}}$

Now $W = W_0 e^{-2\beta t}$

Thus energy decreases η times in $\frac{\ln \eta}{2\beta}$ sec.

$$= \ln \eta \frac{\sqrt{1 + 4Q^2}}{2\omega_0} = \frac{Q \ln \eta}{2\pi \nu_0} \text{ sec.} = 1.033 \text{ ms.}$$

4.111 In a leaky condenser

$$\frac{dq}{dt} = I - I' \quad \text{where } I' = \frac{V}{R} = \text{leak current}$$

Now $V = \frac{q}{C} = -L \frac{dI}{dt} = -L \frac{d}{dt} \left(\frac{dq}{dt} + \frac{V}{R} \right)$
 $= -L \frac{d^2 q}{dt^2} - \frac{L}{RC} \frac{dq}{dt}$

or $\ddot{q} + \frac{1}{RC} \frac{dq}{dt} + \frac{1}{LC} q = 0$

Then $q = q_m e^{-\beta t} \sin(\omega t + \alpha)$

$$(a) \beta = \frac{1}{2RC}, \omega_0^2 = \frac{1}{LC}, \omega = \sqrt{\omega_0^2 - \beta^2}$$

$$= \sqrt{\frac{1}{LC} - \frac{1}{4R^2C^2}}$$

$$(b) Q = \frac{\omega}{2\beta} = RC \sqrt{\frac{1}{LC} - \frac{1}{4R^2C^2}}$$

$$= \frac{1}{2} \sqrt{\frac{4RCR^2}{L} - 1}$$

4.112 Given $V = V_m e^{-\beta t} \sin \omega t$, $\omega = \omega_0$, $\beta T \ll 1$

$$\text{Power loss} = \frac{\text{Energy loss per cycle}}{T}$$

$$= \frac{1}{2} C V_m^2 \times 2\beta$$

(energy decreases as $W_0 e^{-2\beta t}$ so loss per cycle is $W_0 \times 2\beta T$)

$$\text{Thus } \langle P \rangle = \frac{1}{2} C V_m^2 \times \frac{R}{L}$$

$$\text{or } R = \frac{2\langle P \rangle L}{V_m^2 C}$$

$$\text{Hence } Q = \frac{1}{R} \sqrt{\frac{L}{C}} = \sqrt{\frac{C}{L}} \frac{V_m^2}{2\langle P \rangle} = 100 \text{ on putting the vales.}$$

4.113 Energy is lost across the resistance and the mean power loss is

$$\langle P \rangle = R \langle I^2 \rangle = \frac{1}{2} R I_m^2 = 0.2 \text{ mW.}$$

This power should be fed to the circuit to maintain undamped oscillations.

$$4.114 \langle P \rangle = \frac{RCV_m^2}{2L} \text{ as in (4.112). We get } \langle P \rangle = 5 \text{ mW.}$$

4.115 Given $q = q_1 + q_2$

$$I_1 = -\dot{q}_1, I_2 = -\dot{q}_2$$

$$L I_1 = R I_2 = \frac{q}{C}$$

$$\text{Thus } CL \dot{q}_1 + (q_1 + q_2) = 0$$

$$RC \dot{q}_2 + q_1 + q_2 = 0$$

$$\text{Putting } q_1 = A e^{i\omega t} \quad q_2 = B e^{i\omega t}$$

$$(1 - \omega^2 LC)A + B = 0$$

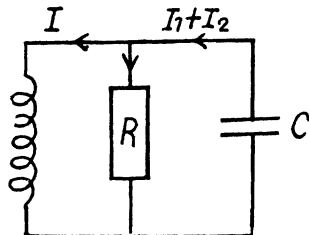

$$A + (1 + i\omega RC)B = 0$$

A solution exists only if

$$(1 - \omega^2 LC)(1 + i\omega RC) = 1$$

or
$$i\omega RC - \omega^2 LC - i\omega^3 LRC^2 = 0$$

or
$$LRC^2\omega^2 - i\omega LC - RC = 0$$

$$\omega^2 - i\omega \frac{1}{RC} - \frac{1}{LC} = 0$$

$$\omega = \frac{i}{2RC} \pm \sqrt{\frac{1}{LC} - \frac{1}{4R^2C^2}} = i\beta \pm \omega_0$$

Thus
$$q_1 = (A_1 \cos \omega_0 t + A_2 \sin \omega_0 t) e^{-\beta t}$$
 etc.

ω_0 is the oscillation frequency. Oscillations are possible only if $\omega_0^2 > 0$

i.e.
$$\frac{1}{4R^2} < \frac{C}{L}.$$

4.116 We have

$$L_1 \dot{I}_1 + R_1 I_1 = L_2 \dot{I}_2 + R_2 I_2$$

$$= - \frac{\int I dt}{C}$$

$$I = I_1 + I_2$$

Then differentiating we have the equations

$$L_1 C \ddot{I}_1 + R_1 C \dot{I}_1 + (I_1 + I_2) = 0$$

$$L_2 C \ddot{I}_2 + R_2 C \dot{I}_2 + (I_1 + I_2) = 0$$

Look for a solution

$$I_1 = A_1 e^{\alpha t}, I_2 = A_2 e^{\alpha t}$$

Then

$$(1 + \alpha^2 L_1 C + \alpha R_1 C) A_1 + A_2 = 0$$

$$A_1 + (1 + \alpha^2 L_2 C + \alpha R_2 C) A_2 = 0$$

This set of simultaneous equations has a nontrivial solution only if

$$(1 + \alpha^2 L_1 C + \alpha R_1 C)(1 + \alpha^2 L_2 C + \alpha R_2 C) = 1$$

or
$$\alpha^3 + \alpha^2 \frac{L_1 R_2 + L_2 R_1}{L_1 L_2} + \alpha \frac{L_1 + L_2 + R_1 R_2 C}{L_1 L_2 C} + \frac{R_1 + R_2}{L_1 L_2 C} = 0$$

This cubic equation has one real root which we ignore and two complex conjugate roots. We require the condition that this pair of complex conjugate roots is identical with the roots of the equation

$$\alpha^2 LC + \alpha RC + 1 = 0$$

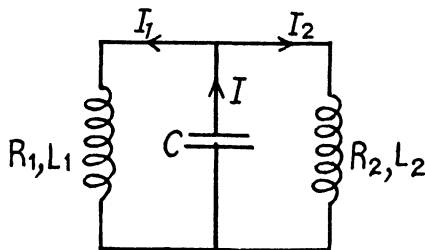

The general solution of this problem is not easy. We look for special cases. If $R_1 = R_2 = 0$, then

$$R = 0 \text{ and } L = \frac{L_1 L_2}{L_1 + L_2}. \text{ If } L_1 = L_2 = 0, \text{ then}$$

$L = 0$ and $R = R_1 R_2 / (R_1 + R_2)$. These are the quoted solution but they are misleading.

We shall give the solution for small R_1, R_2 . Then we put $\alpha = -\beta + i\omega$ when β is small

$$\text{We get } (1 - \omega^2 L_1 C - 2i\beta\omega L_1 C - \beta R_1 C + i\omega R_1 C)$$

$$(1 - \omega^2 L_2 C - 2i\beta\omega L_2 C - \beta R_2 C + i\omega R_2 C) = 1$$

(we neglect β^2 & $\beta R_1, \beta R_2$). Then

$$(1 - \omega^2 L_1 C)(1 - \omega^2 L_2 C) = 1 \Rightarrow \omega^2 = \frac{L_1 + L_2}{L_1 L_2 C}$$

This is identical with $\omega^2 = \frac{1}{LC}$ if $L = \frac{L_1 L_2}{L_1 + L_2}$.

$$\text{also } (2\beta L_1 - R_1)(1 - \omega^2 L_2 C) + (2\beta L_2 - R_2)(1 - \omega^2 L_1 C) = 0$$

$$\text{This gives } \beta = \frac{R}{2L} = \frac{R_1 L_2^2 + R_2 L_1^2}{2L_1 L_2 (L_1 + L_2)} \Rightarrow R = \frac{R_1 L_2^2 + R_2 L_1^2}{(L_1 + L_2)^2}.$$

$$4.117 \quad o = \frac{q}{C} + L \frac{dI}{dt} + RI, \quad I = + \frac{dq}{dt}$$

$$\text{For the critical case } R = 2\sqrt{\frac{L}{C}}$$

$$\text{Thus } LC \ddot{q} + 2\sqrt{LC} \dot{q} + q = 0$$

Look for a solution with $q \propto e^{\alpha t}$

$$\alpha = -\frac{1}{\sqrt{LC}}.$$

An independent solution is $t e^{\alpha t}$. Thus

$$q = (A + Bt) e^{-t/\sqrt{LC}},$$

$$\text{At } t = 0 \quad q = C V_0 \text{ thus } A = C V_0$$

$$\text{Also at } t = 0 \quad \dot{q} = I = 0$$

$$0 = B - A \frac{1}{\sqrt{LC}} \Rightarrow B = V_0 \sqrt{\frac{C}{L}}$$

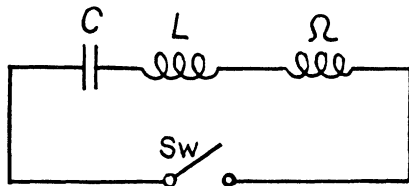

Thus finally

$$\begin{aligned} I &= \frac{dq}{dt} = V_0 \sqrt{\frac{C}{L}} e^{-t/\sqrt{LC}} \\ &- \frac{1}{\sqrt{LC}} \left(C V_0 + V_0 \sqrt{\frac{C}{L}} t \right) e^{-t/\sqrt{LC}} \\ &= - \frac{V_0}{L} t e^{-t/\sqrt{LC}} \end{aligned}$$

The current has been defined to increase the charge. Hence the minus sign.

The current is maximum when

$$\frac{dI}{dt} = - \frac{V_0}{L} e^{-t/\sqrt{LC}} \left(1 - \frac{t}{\sqrt{LC}} \right) = 0$$

This gives $t = \sqrt{LC}$ and the magnitude of the maximum current is

$$|I_{\max}| = \frac{V_0}{e} \sqrt{\frac{C}{L}}.$$

4.118 The equation of the circuit is (I is the current)

$$L \frac{dI}{dt} + RI = V_m \cos \omega t$$

From the theory of differential equations

$$I = I_P + I_C$$

where I_P is a particular integral and I_C is the complementary function (Solution of the differential equation with the RHS = 0). Now

$$I_C = I_{CO} e^{-tR/L}$$

and for I_P we write $I_P = I_m \cos(\omega t - \varphi)$

Substituting we get

$$I_m = \frac{V_m}{\sqrt{R^2 + \omega^2 L^2}}, \quad \varphi = \tan^{-1} \frac{\omega L}{R}$$

Thus

$$I_m = \frac{V_m}{\sqrt{R^2 + \omega^2 L^2}} \cos(\omega t - \varphi) + I_{CO} e^{-tR/L}$$

Now in an inductive circuit $I = 0$ at $t = 0$

because a current cannot change suddenly.

Thus

$$I_{CO} = - \frac{V_m}{\sqrt{R^2 + \omega^2 L^2}} \cos \varphi$$

and so

$$I = \frac{V_m}{\sqrt{R^2 + \omega^2 L^2}} \left[\cos(\omega t - \varphi) - \cos \varphi e^{-tR/L} \right]$$

4.119 Here the equation is (Q is charge, on the capacitor)

$$\frac{Q}{C} + R \frac{dQ}{dt} = V_m \cos \omega t$$

A solution subject to $Q = 0$ at $t = 0$ is of the form (as in the previous problem)

$$Q = Q_m \left[\cos(\omega t - \bar{\varphi}) - \cos \bar{\varphi} e^{-t/RC} \right]$$

Substituting back

$$\begin{aligned} & \frac{Q_m}{C} \cos(\omega t - \bar{\varphi}) - \omega R Q_m \sin(\omega t - \bar{\varphi}) \\ & = V_m \cos \omega t \\ & = V_m \{ \cos \bar{\varphi} \cos(\omega t - \bar{\varphi}) - \sin \bar{\varphi} \sin(\omega t - \bar{\varphi}) \} \end{aligned}$$

so

$$\begin{aligned} Q_m &= C V_m \cos \bar{\varphi} \\ \omega R Q_m &= V_m \sin \bar{\varphi} \end{aligned}$$

This leads to

$$Q_m = \frac{C V_m}{\sqrt{1 + (\omega R C)^2}}, \quad \tan \bar{\varphi} = \omega R C$$

Hence

$$I = \frac{dQ}{dt} = \frac{V_m}{\sqrt{R^2 + \left(\frac{1}{\omega C}\right)^2}} \left[-\sin(\omega t - \bar{\varphi}) + \frac{\cos^2 \bar{\varphi}}{\sin \bar{\varphi}} e^{-t/RC} \right]$$

The solution given in the book satisfies $I = 0$ at $t = 0$. Then $Q = 0$ at $t = 0$ but this will not satisfy the equation at $t = 0$. Thus $I \neq 0$, (Equation will be satisfied with $I = 0$ only if $Q \neq 0$ at $t = 0$)

With our I ,

$$I(t = 0) = \frac{V_m}{R}$$

4.120 The current lags behind the voltage by the phase angle

$$\varphi = \tan^{-1} \frac{\omega L}{R}$$

Now $L = \mu_0 n^2 \pi a^2 l$, $l =$ length of the solenoid

$$R = \frac{\rho \cdot 2 \pi a n \cdot l}{\pi b^2}, \quad 2b = \text{diameter of the wire}$$

But $2bn = 1 \quad \therefore b = \frac{1}{2n}$

Then

$$\begin{aligned} \varphi &= \tan^{-1} \frac{\mu_0 n^2 l \pi a^2 \cdot 2 \pi \nu}{\rho \cdot 2 \pi a n l} \times \pi \frac{1}{4n^2} \\ &= \tan^{-1} \frac{\mu_0 \pi^2 a \nu}{4 \rho n}. \end{aligned}$$

4.121 Here $V = V_m \cos \omega t$

$$I = I_m \cos(\omega t + \varphi)$$

where
$$I_m = \frac{V_m}{\sqrt{R^2 + \left(\frac{1}{\omega C}\right)^2}}, \quad \tan \varphi = \frac{1}{\omega R C}$$

Now
$$R^2 + \frac{1}{(\omega C)^2} = \left(\frac{V_m}{I_m}\right)^2$$

$$\frac{1}{\omega R C} = \sqrt{\left(\frac{V_m}{R I_m}\right)^2 - 1}$$

Thus the current is ahead of the voltage by

$$\varphi = \tan^{-1} \frac{1}{\omega R C} = \tan^{-1} \sqrt{\left(\frac{V_m}{R I_m}\right)^2 - 1} = 60^\circ$$

4.122 Here
$$V = IR + \int_0^t I dt$$

or
$$R\dot{I} + \frac{1}{C}I = \dot{V} = -\omega V_0 \sin \omega t$$

Ignoring transients, a solution has the form

$$I = I_0 \sin(\omega t - \alpha)$$

$$\omega R I_0 \cos(\omega t - \alpha) + \frac{I_0}{C} \sin(\omega t - \alpha) = -\omega V_0 \sin \omega t$$

$$= -\omega V_0 \{ \sin(\omega t - \alpha) \cos \alpha + \cos(\omega t - \alpha) \sin \alpha \}$$

so

$$R I_0 = -V_0 \sin \alpha$$

$$\frac{I_0}{\omega C} = -V_0 \cos \alpha \quad \alpha = \pi + \tan^{-1}(\omega R C)$$

$$I_0 = \frac{V_0}{\sqrt{R^2 + \left(\frac{1}{\omega C}\right)^2}}$$

$$I = I_0 \sin(\omega t - \tan^{-1} \omega R C - \pi) = -I_0 \sin(\omega t - \tan^{-1} \omega R C)$$

Then
$$Q = \int_0^t I dt = Q_0 + \frac{I_0}{\omega} \cos(\omega t - \tan^{-1} \omega R C)$$

It satisfies

$$V_0(1 + \cos \omega t) = R \frac{dQ}{dt} + \frac{Q}{C}$$

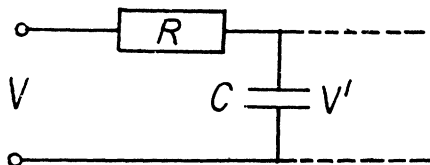

$$\text{if } V_0(1 + \cos \omega t) = -RI_0 \sin(\omega t - \tan^{-1} \omega RC) + \frac{Q_0}{C} + \frac{I_0}{\omega C} \cos(\omega t - \tan^{-1} \omega RC)$$

Thus

$$Q_0 = CV_0$$

$$\text{and } \left. \begin{aligned} \frac{I_0}{\omega C} &= V_0 / \sqrt{1 + (\omega RC)^2} \\ RI_0 &= \frac{V_0 \omega RC}{\sqrt{1 + (\omega RC)^2}} \end{aligned} \right\} \text{checks}$$

$$\text{Hence } V' = \frac{Q}{C} = V_0 + \frac{V_0}{\sqrt{1 + (\omega RC)^2}} \cos(\omega t - \alpha)$$

$$(b) \frac{V_0}{\eta} = \frac{V_0}{\sqrt{1 + (\omega RC)^2}}$$

or

$$\eta^2 - 1 = \omega^2 (RC)^2$$

or

$$RC = \sqrt{\eta^2 - 1} / \omega = 22 \text{ ms.}$$

4.123

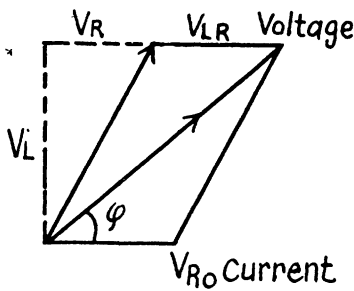

(a)

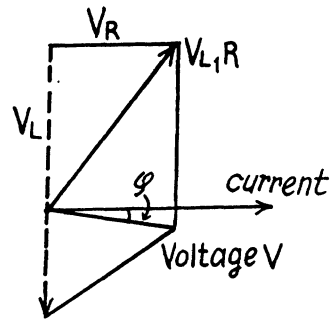

(b)

$$(b) \tan \varphi = \frac{\omega L - \frac{1}{\omega C}}{R} = -ve$$

as

$$\omega^2 < \frac{1}{LC}$$

$$4.124 (a) I_m = \frac{V_m}{\sqrt{R^2 + \left(\omega L - \frac{1}{\omega C}\right)^2}} = 4.48 \text{ A}$$

$$(b) \tan \varphi = \frac{\omega L - \frac{1}{\omega C}}{R}, \varphi = -60^\circ$$

Current lags behind the voltage V by φ

$$(c) V_C = \frac{I_m}{\omega C} = 0.65 \text{ kV}$$

$$V_{L/R} = I_m \sqrt{R^2 + \omega^2 L^2} = 0.5 \text{ kV}$$

$$\begin{aligned}
 4.125 \text{ (a) } V_C &= \frac{1}{\omega C} \frac{V_m}{\sqrt{R^2 + \left(\omega L - \frac{1}{\omega C}\right)^2}} \\
 &= \frac{V_m}{\sqrt{(\omega R C)^2 + (\omega^2 L C - 1)^2}} = \frac{V_m}{\sqrt{\left(\frac{\omega^2}{\omega_0^2} - 1\right)^2 + 4\beta^2 \omega^2 / \omega_0^4}} \\
 &= \frac{V_m}{\sqrt{\left(\frac{\omega^2}{\omega_0^2} - 1 + \frac{2\beta^2}{\omega_0^2}\right)^2 + \frac{4\beta^2}{\omega_0^2} - \frac{4\beta^4}{\omega_0^4}}}
 \end{aligned}$$

This is maximum when $\omega^2 = \omega_0^2 - 2\beta^2 = \frac{1}{LC} - \frac{R^2}{2L^2}$

$$\begin{aligned}
 \text{(b) } V_L &= I_m \omega L = V_m \frac{\omega L}{\sqrt{R^2 + \left(\omega L - \frac{1}{\omega C}\right)^2}} \\
 &= \frac{V_m L}{\sqrt{\frac{R^2}{\omega^2} + \left(L - \frac{1}{\omega^2 C}\right)^2}} = \frac{V_m L}{\sqrt{L^2 - \frac{1}{\omega^2} \left(\frac{2L}{C} - R^2\right) + \frac{1}{\omega^4 C^2}}} \\
 &= \frac{V_m L}{\sqrt{\left(\frac{1}{\omega^2 C} - \left(L - \frac{CR^2}{2}\right)\right)^2 + L^2 - \left(L - \frac{1}{2}CR^2\right)^2}}
 \end{aligned}$$

This is maximum when

$$\frac{1}{\omega^2 C} = L - \frac{1}{2}CR^2$$

or

$$\begin{aligned}
 \omega^2 &= \frac{1}{LC - \frac{1}{2}C^2R^2} = \frac{1}{\frac{1}{\omega_0^2} - \frac{2\beta^2}{\omega_0^4}} \\
 &= \frac{\omega_0^4}{\omega_0^2 - 2\beta^2} \quad \text{or} \quad \omega = \frac{\omega_0^2}{\sqrt{\omega_0^2 - 2\beta^2}}.
 \end{aligned}$$

$$4.126. \quad V_L = I_m \sqrt{R^2 + \omega^2 L^2}$$

$$= \frac{V_m \sqrt{R^2 + \omega^2 L^2}}{\sqrt{R^2 + \left(\omega L - \frac{1}{\omega C}\right)^2}}$$

for a given ω, L, R , this is maximum when

$$\frac{1}{\omega C} = \omega L \quad \text{or} \quad C = \frac{1}{\omega^2 L} = 28.2 \mu\text{F}.$$

$$\text{For that } C, \quad V_L = \frac{V \sqrt{R^2 + \omega^2 L^2}}{R} = V \sqrt{1 + (\omega L/R)^2} = 0.540 \text{ kV}$$

$$\text{At this } C \quad V_C = \frac{1}{\omega C} \frac{V_m}{R} = \frac{V_m \omega L}{R} = .509 \text{ kV}$$

4.127

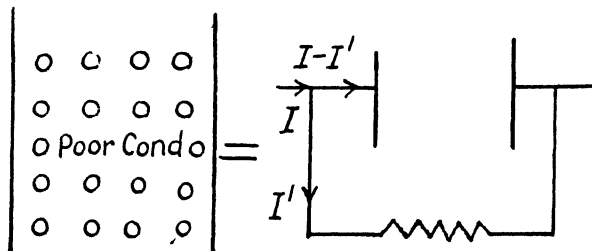

We use the complex voltage $V = V_m e^{i\omega t}$. Then the voltage across the capacitor is

$$(I - I') \frac{1}{i\omega C}$$

and that across the resistance RI' and both equal V . Thus

$$I' = \frac{V_m}{R} e^{i\omega t}, \quad I - I' = i\omega C V_m e^{i\omega t}$$

Hence

$$I = \frac{V_m}{R} (1 + i\omega RC) e^{i\omega t}$$

The actual voltage is obtained by taking the real part. Then

$$I = \frac{V_m}{R} \sqrt{1 + (\omega RC)^2} \cos(\omega t + \varphi)$$

Where

$$\tan \varphi = \omega RC$$

Note \rightarrow A condenser with poorly conducting material (dielectric of high resistance) between the plates is equivalent to an ideal condenser with a high resistance joined in parallel between its plates.

$$4.128 \quad L_1 \frac{dI_1}{dt} + \frac{\int I_1 dt}{C} = -L_{12} \frac{dI_2}{dt}$$

$$L_2 \frac{dI_2}{dt} = -L_{12} \frac{dI_1}{dt}$$

from the second equation

$$L_2 I_2 = -L_{12} I_1$$

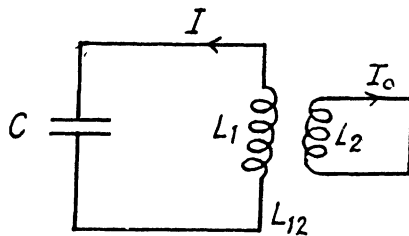

Then

$$\left(L_1 - \frac{L_{12}^2}{L_2} \right) \ddot{I}_1 + \frac{I_1}{C} = 0$$

Thus the current oscillates with frequency

$$\omega = \frac{1}{\sqrt{C \left(L_1 - \frac{L_{12}^2}{L_2} \right)}}$$

$$4.129 \quad \text{Given } V = V_m \cos \omega t$$

$$I = I_m \cos(\omega t - \varphi)$$

where

$$I_m = \frac{V_m}{\sqrt{R^2 + \left(\omega L - \frac{1}{\omega C} \right)^2}}$$

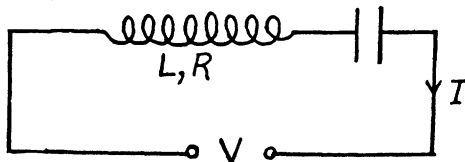

$$\text{Then, } V_C = \frac{\int I dt}{C} = \frac{I_m \sin(\omega t - \varphi)}{\omega C}$$

$$= \frac{V_m}{\sqrt{(1 - \omega^2 LC)^2 + (\omega RC)^2}} \sin(\omega t - \varphi)$$

As resonance the voltage amplitude across the capacitor

$$= \frac{V_m}{RC \frac{1}{\sqrt{LC}}} = \sqrt{\frac{L}{CR^2}} V_m = n V_m$$

So

$$\frac{L}{CR^2} = n^2$$

Now

$$Q = \sqrt{\frac{L}{CR^2} - \frac{1}{4}} = \sqrt{n^2 - \frac{1}{4}}$$

4.130 For maximum current amplitude

$$I_m = \frac{V_m}{\sqrt{R^2 + \left(\omega L - \frac{1}{\omega C} \right)^2}}$$

$$L = \frac{1}{\omega^2 C} \text{ and then } I_{m0} = \frac{V_m}{R}$$

Now
$$\frac{I_{m0}}{\eta} = \frac{V_m}{\sqrt{R^2 + \frac{(n-1)^2}{\omega^2 C^2}}}$$

So
$$\eta = \sqrt{1 + \frac{(n-1)^2}{(\omega RC)^2}}$$

$$\omega RC = \frac{n-1}{\sqrt{\eta^2 - 1}}$$

Now
$$Q = \sqrt{\left(\frac{L}{CR^2}\right)^2 - \frac{1}{4}} = \sqrt{\left(\frac{1}{\omega RC}\right)^2 - \frac{1}{4}} = \sqrt{\frac{\eta^2 - 1}{(n-1)^2} - \frac{1}{4}}$$

4.131 At resonance

$$\omega_0 L = (\omega_0 C)^{-1} \text{ or } \omega_0 = \frac{1}{\sqrt{LC}},$$

and
$$(I_m)_{res} = \frac{V_m}{R}.$$

Now
$$\frac{V_m}{nR} = \frac{V_m}{\sqrt{R^2 + \left(\omega_1 L - \frac{1}{\omega_1 C}\right)^2}} = \frac{V_m}{\sqrt{R^2 + \left(\omega_2 L - \frac{1}{\omega_2 C}\right)^2}}$$

Then
$$\omega_1 L - \frac{1}{\omega_1 C} = \sqrt{n^2 - 1} R$$

$$\omega_2 L - \frac{1}{\omega_2 C} = +\sqrt{n^2 - 1} R \quad (\text{assuming } \omega_2 > \omega_1)$$

or
$$\omega_1 - \frac{\omega_0^2}{\omega_1} = -\omega_2 + \frac{\omega_0^2}{\omega_2} = -\sqrt{n^2 - 1} \frac{R}{L}$$

or
$$\omega_1 + \omega_2 = \frac{\omega_0^2}{\omega_1 \omega_2} (\omega_1 + \omega_2) \Rightarrow \omega_0 = \sqrt{\omega_1 \omega_2}$$

and
$$\omega_2 - \omega_1 = \sqrt{n^2 - 1} \frac{R}{L}$$

$$\beta = \frac{R}{2L} = \frac{\omega_2 - \omega_1}{2\sqrt{n^2 - 1}}$$

and
$$Q = \sqrt{\frac{\omega_0^2}{4\beta^2} - \frac{1}{4}} = \sqrt{\frac{(n^2 - 1)\omega_1 \omega_2}{(\omega_2 - \omega_1)^2} - \frac{1}{4}}$$

4.132 $Q = \frac{\omega}{2\beta} \approx \frac{\omega_0}{2\beta}$ for low damping.

Now $\frac{I_m}{\sqrt{2}} = \frac{R I_m}{\sqrt{R^2 + \left(\omega L - \frac{1}{\omega C}\right)^2}}$, I_m = current amplitude at resonance

or $\omega - \frac{\omega_0^2}{\omega} = \pm \frac{R}{L} = \pm 2\beta$

Thus $\omega = \omega_0 \pm \beta$

So $\Delta\omega = 2\beta$ and $Q = \frac{\omega_0}{\Delta\omega}$.

4.133 At resonance $\omega = \omega_0$

$$I_m(\omega_0) = \frac{V_m}{R}$$

$$\begin{aligned} \text{Then } I_m(\eta\omega_0) &= \frac{V_m}{\sqrt{R^2 + \left(\eta\omega_0 L - \frac{1}{\eta\omega_0 C}\right)^2}} \\ &= \frac{V_m}{\sqrt{R^2 + \left(\eta - \frac{l}{\eta}\right)^2 \frac{L}{C}}} = \frac{V_m}{\sqrt{1 + \left(Q^2 + \frac{l}{4}\right) \left(\eta - \frac{1}{\eta}\right)^2 \frac{L}{C}}} \end{aligned}$$

4.134 The a.c. current must be

$$I = I_0 \sqrt{2} \sin \omega t$$

Then D.C. component of the rectified current is

$$\begin{aligned} \langle I' \rangle &= \frac{1}{T} \int_0^{T/2} I_0 \sqrt{2} \sin \omega t \, dt \\ &= I_0 \sqrt{2} \frac{1}{2\pi} \int_0^\pi \sin \theta \, d\theta \\ &= \frac{I_0 \sqrt{2}}{\pi} \end{aligned}$$

Since the charge deposited must be the same

$$I_0 t_0 = \frac{I_0 \sqrt{2}}{\pi} t \quad \text{or} \quad t = \frac{\pi t_0}{\sqrt{2}}$$

The answer is incorrect.

$$4.135 \text{ (a) } I(t) = I_1 \frac{t}{T} \quad 0 \leq t < T$$

$$I(t \pm T) = I(t)$$

Now mean current

$$\langle I \rangle = \frac{1}{T} \int_0^T I_1 \frac{t}{T} dt = I_1 \frac{T^2/2}{T^2} = I_1/2$$

Then $I_1 = 2I_0$ since $\langle I \rangle = I_0$.

Now mean square current $\langle I^2 \rangle$,

$$= 4I_0^2 \frac{1}{T} \int_0^T \frac{t^2}{T^2} dt = \frac{4I_0^2}{3}$$

so effective current = $\frac{2I_0}{\sqrt{3}}$.

(b) In this case $I = I_1 |\sin \omega t|$

$$\begin{aligned} \text{and} \quad I_0 &= \frac{1}{T} \int_0^T I_1 |\sin \omega t| dt \\ &= \frac{1}{2\pi} I_1 \int_0^{2\pi} |\sin \theta| d\theta = \frac{I_1}{\pi} \int_0^{\pi} \sin \theta d\theta = \frac{2I_1}{\pi} \end{aligned}$$

$$\text{So} \quad I_1 = \frac{\pi I_0}{2}$$

$$\text{Then, mean square current} = \langle I^2 \rangle = \frac{\pi^2 I_0^2}{4T} \int_0^T \sin^2 \omega t dt$$

$$= \frac{\pi^2 I_0^2}{4} \times \frac{1}{2\pi} \int_0^{2\pi} \sin^2 \theta d\theta = \frac{\pi^2 I_0^2}{8}$$

so effective current = $\frac{\pi I_0}{\sqrt{8}}$.

$$4.136 \quad P_{d.c.} = \frac{V_0^2}{R}$$

$$P_{a.c.} = \frac{V_0^2}{\sqrt{R^2 + \omega^2 L^2}} \cdot \frac{R}{\sqrt{R^2 + \omega^2 L^2}} = \frac{v_0^2/R}{1 + \left(\frac{\omega L}{R}\right)^2} = \frac{P_{d.c.}}{\eta}$$

Thus
$$\frac{\omega L}{R} = \sqrt{\eta - 1}$$

or
$$\omega = \frac{R}{L} \sqrt{\eta - 1}$$

$$v = \frac{R}{2\pi L} \sqrt{\eta - 1} = 2 \text{ kHz of on putting the values.}$$

4.137 $Z = \sqrt{R^2 + X_L^2}$ or $R_0 = \sqrt{Z^2 - X_L^2}$

The
$$\tan \theta = \frac{X_L}{\sqrt{Z^2 - X_L^2}}$$

So
$$\cos \varphi = \frac{\sqrt{Z^2 - X_L^2}}{Z} = \sqrt{1 - \left(\frac{X_L}{Z}\right)^2}$$

$$\varphi = \cos^{-1} \sqrt{1 - \left(\frac{X_L}{Z}\right)^2} = 37^\circ.$$

The current lags by φ behind the voltage.

also
$$P = VI \cos \varphi = \frac{V^2}{Z^2} \sqrt{Z^2 - X_L^2} = .160 \text{ kW.}$$

4.138
$$P = \frac{V^2(R + r)}{(R + r)^2 + \omega^2 L^2}$$

This is maximum when $R + r = \omega L$ for

$$P = \frac{V^2}{R + r + \frac{(\omega L)^2}{R + r}} = \frac{V^2}{\left[\sqrt{R + r} - \frac{\omega L}{\sqrt{R + r}}\right]^2 + 2\omega L}$$

Thus $R = \omega L - r$ for maximum power and $P_{\max} = \frac{V^2}{2\omega L}$.

Substituting the values, we get $R = 200 \Omega$ and $P_{\max} = .114 \text{ kW.}$

4.139
$$P = \frac{V^2 R}{R^2 + (X_L - X_C)^2}$$

Varying the capacitor does not change R so if P increases n times

$$Z = \sqrt{R^2 + (X_L - X_C)^2} \text{ must decrease } \sqrt{n} \text{ times}$$

Thus
$$\cos \varphi = \frac{R}{Z} \text{ increases } \sqrt{n} \text{ times}$$

\therefore % increase in $\cos \varphi = (\sqrt{n} - 1) \times 100 \% = 30.4\%$.

$$4.140 \quad P = \frac{V^2 R}{R^2 + (X_L - X_C)^2}$$

At resonance $X_L = X_C \Rightarrow \omega_0 = \frac{1}{\sqrt{LC}}$.

Power generated will decrease n times when

$$(X_L - X_C)^2 = \left(\omega L - \frac{1}{\omega C} \right)^2 = (n-1)R^2$$

or $\omega - \frac{\omega_0^2}{\omega} = \pm \sqrt{n-1} \frac{R}{L} = \pm \sqrt{n-1} 2\beta$.

Thus $\omega^2 \mp 2\sqrt{n-1} \beta \omega - \omega_0^2 = 0$

$$\left(\omega \mp \sqrt{n-1} \beta \right)^2 = \omega_0^2 + (n-1)\beta^2$$

or $\frac{\omega}{\omega_0} = \sqrt{1 + (n-1)\beta^2/\omega_0^2} \pm \sqrt{n-1} \beta/\omega_0$

(taking only the positive sign in the first term to ensure positive value for $\frac{\omega}{\omega_0}$.)

Now
$$Q = \frac{\omega}{2\beta} = \frac{1}{2} \sqrt{\left(\frac{\omega_0}{\beta} \right)^2 - 1}$$

$$\frac{\omega_0}{\beta} = \sqrt{1 + 4Q^2}$$

Thus $\frac{\omega}{\omega_0} = \sqrt{1 + \frac{n-1}{(1+4Q^2)}} \pm \sqrt{n-1} / \sqrt{1+4Q^2}$

For large Q

$$\left| \frac{\omega - \omega_0}{\omega_0} \right| = \frac{\sqrt{en-1}}{2Q} = \frac{\sqrt{en-1}}{2Q} \times 100\% = 0.5\%$$

4.141 We have

$$V_1 = \frac{VR}{\sqrt{(R+R_1)^2 + X_L^2}}, \quad V_2 = \frac{V\sqrt{R_1^2 + X_L^2}}{\sqrt{(R+R_1)^2 + X_L^2}}$$

so $(R+R_1)^2 + X_L^2 = \left(\frac{VR}{V_1} \right)^2, \quad R_1^2 + X_L^2 = \left(\frac{V_2 R}{V_1} \right)^2$

Hence $R^2 + 2RR_1 = \frac{R^2}{V_1^2} (V^2 - V_2^2)$

or $R_1 = \frac{R}{2V_1^2} (V^2 - V_2^2 - V_1^2)$

$$\begin{aligned} \text{Heat generated in the coil} &= \frac{V^2 R_1}{(R_1 + R_2)^2 + X_L^2} = \frac{V_1^2}{R^2} \times R_1 = \frac{V_1^2}{R^2} \times \frac{R^2}{2V_1^2} (V^2 - V_1^2 - V_2^2) \\ &= \frac{V^2 - V_1^2 - V_2^2}{2R} = 30 \text{ W} \end{aligned}$$

4.142 Here $I_2 = \frac{V}{R}$, $V =$ effective voltage

$$I_1 = \frac{V}{\sqrt{R^2 + X_L^2}}$$

$$\text{and } I = \frac{V \sqrt{(R + R_1)^2 + X_L^2}}{R \sqrt{R_1^2 + X_L^2}} = \frac{V}{R_{\text{eff}}}$$

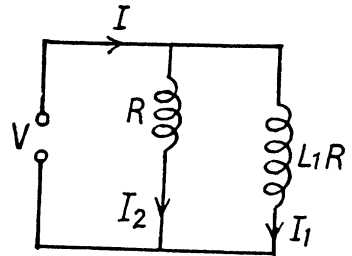

R_{eff} is the impedance of the coil & the resistance in parallel.

$$\begin{aligned} \text{Now } \frac{I^2 - I_2^2}{I_2^2} &= \frac{R^2 + 2RR_1}{R_1^2 + X_L^2} = \left(\frac{I_1}{I_2}\right)^2 + \frac{2RR_1}{R^2 + X_L^2} \\ \frac{I^2 - I_2^2 - I_1^2}{I_2^2} &= \frac{2RR_1}{R^2 + X_L^2} \end{aligned}$$

Now mean power consumed in the coil

$$= I_1^2 R_1 = \frac{V^2 R_1}{R_2 + X_L^2} = I_2^2 R \cdot \frac{I^2 - I_1^2 - I_2^2}{2I_2^2} = \frac{1}{2} R (I^2 - I_1^2 - I_2^2) = 2.5 \text{ W.}$$

$$4.143 \quad \frac{1}{Z} = \frac{1}{R} + \frac{1}{\frac{1}{i\omega C}} = \frac{1}{R} + i\omega C = \frac{1 + i\omega RC}{R}$$

$$|Z| = \frac{R}{\sqrt{1 + (\omega RC)^2}} = 40 \Omega$$

4.144 (a) For the resistance, the voltage and the current are in phase. For the coil the voltage is ahead of the current by less than 90° . The current is obtained by addition because the elements are in parallel.

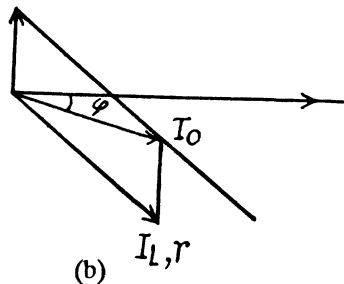
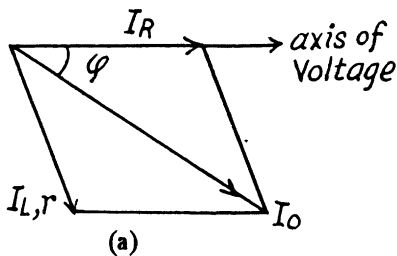

- (b) I_C is ahead of the voltage by 90° .
 (c) The coil has no resistance so I_L is 90° behind the voltage.

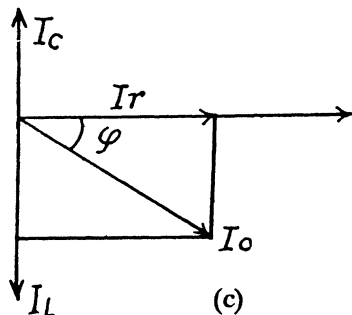

4.145 When the coil and the condenser are in parallel, the equation is

$$L \frac{dI_1}{dt} + RI_1 = \int I_2 dt = V_m \cos \omega t$$

$$I = I_1 + I_2$$

Using complex voltages

$$I_1 = \frac{V_m e^{i\omega t}}{R + i\omega L}, \quad I_2 = i\omega C V_m e^{i\omega t}$$

and

$$I = \left(\frac{1}{R + i\omega L} + i\omega C \right) V_m e^{i\omega t} = \left[\frac{R - i\omega L + i\omega C(R^2 + \omega^2 L^2)}{R^2 + \omega^2 L^2} \right] V_m e^{i\omega t}$$

Thus, taking real parts
$$I = \frac{V_m}{|Z(\omega)|} \cos(\omega t - \varphi)$$

where
$$\frac{1}{|Z(\omega)|} = \frac{[R^2 + \{\omega C(R^2 + \omega^2 L^2) - \omega L\}^2]}{(R^2 + \omega^2 L^2)^{1/2}}$$

and
$$\tan \varphi = \frac{\omega L - \omega C(R^2 + \omega^2 L^2)}{R}$$

- (a) To get the frequency of resonance we must define what we mean by resonance. One definition requires the extremum (maximum or minimum) of current amplitude. The other definition requires rapid change of phase with φ passing through zero at resonance. For the series circuit.

$$I_m = \frac{V_m}{\left\{ R^2 + \left(\omega L - \frac{1}{\omega C} \right)^2 \right\}^{1/2}} \quad \text{and} \quad \tan \varphi = \frac{\omega L - \frac{1}{\omega C}}{R}$$

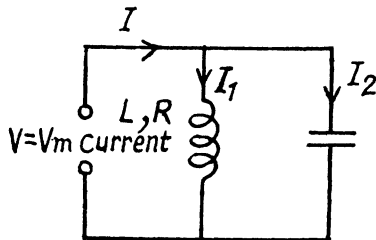

both definitions give $\omega^2 = \frac{1}{LC}$ at resonance. In the present case the two definitions do not agree (except when $R = 0$). The definition that has been adopted in the answer given in the book is the vanishing of phase. This requires

$$C(R^2 + \omega^2 L^2) = L$$

or
$$\omega^2 = \frac{1}{LC} - \frac{R^2}{L^2} = \omega_{res}^2, \quad \omega_{res} = 31.6 \times 10^3 \text{ rad/s.}$$

Note that for small R , φ rapidly changes from $-\frac{\pi}{2}$ to $+\frac{\pi}{2}$ as ω passes through ω_{res} from $< \omega_{res}$ to $> \omega_{res}$.

(b) At resonance
$$I_m = \frac{V_m R}{L/C} = V_m \frac{CR}{L}$$

so $I =$ effective value of total current $= V \frac{CR}{L} = 3.1 \text{ mA.}$

similarly
$$I_L = \frac{V}{\sqrt{L/C}} = V \sqrt{\frac{C}{L}} = 0.98 \text{ A.}$$

$$I_C = \omega C V = V \sqrt{\frac{C}{L} - \frac{R^2 C^2}{L^2}} = 0.98 \text{ A.}$$

Note :- The vanishing of phase (its passing through zero) is considered a more basic definition of resonance.

4.146 We use the method of complex voltage

$$V = V_0 e^{i\omega t}$$

$$\text{Then } I_C = \frac{V_0 e^{i\omega t}}{\frac{1}{i\omega C}} = i\omega C V_0 e^{i\omega t}$$

$$I_{L,R} = \frac{V_0 e^{i\omega t}}{R + i\omega L}$$

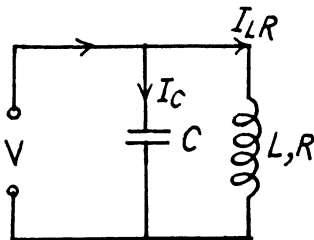

$$I = I_C + I_{L,R} = V_0 \frac{R - i\omega L + i\omega C(R^2 + \omega^2 L^2)}{R^2 + \omega^2 L^2} e^{i\omega t}$$

Then taking the real part

$$I = \frac{V_0 \sqrt{R^2 + \{\omega C(R^2 + \omega^2 L^2) - \omega L\}^2}}{R^2 + \omega^2 L^2} \cos(\omega t - \varphi)$$

where
$$\tan \varphi = \frac{\omega L - \omega C(R^2 + \omega^2 L^2)}{R}$$

4.147 From the previous problem

$$\begin{aligned}
 Z &= \frac{R^2 + \omega^2 L^2}{\sqrt{R^2 + \{\omega C(R^2 + \omega^2 L^2) - \omega L\}^2}} \\
 &= \frac{R^2 + \omega^2 L^2}{\sqrt{(R^2 + \omega^2 L^2)(1 - 2\omega^2 LC) + \omega^2 C^2(R^2 + \omega^2 L^2)^2}} \\
 &= \frac{\sqrt{R^2 + \omega^2 L^2}}{\sqrt{(1 - 2\omega^2 LC) + \omega^2 C^2(R^2 + \omega^2 L^2)}} = \frac{\sqrt{R^2 + \omega^2 L^2}}{\sqrt{(1 - \omega^2 LC)^2 + (\omega RC)^2}}
 \end{aligned}$$

4.148 (a) We have

$$\varepsilon = -\frac{d\Phi}{dt} = \omega \Phi_0 \sin \omega t = L\dot{I} + RI$$

Put $I = I_m \sin(\omega t - \varphi)$. Then

$$\begin{aligned}
 \omega \Phi_0 \sin \omega t &= \omega \Phi_0 \{ \sin(\omega t - \varphi) \cos \varphi + \cos(\omega t - \varphi) \sin \varphi \} \\
 &= LI_m \omega \cos(\omega t - \varphi) + RI_m \sin(\omega t - \varphi)
 \end{aligned}$$

so $RI_m = \omega \Phi_0 \cos \varphi$ and $LI_m = \Phi_0 \sin \varphi$

or
$$I_m = \frac{\omega \Phi_0}{\sqrt{R^2 + \omega^2 L^2}} \text{ and } \tan \varphi = \frac{\omega L}{R}.$$

(b) Mean mechanical power required to maintain rotation = energy loss per unit time

$$= \frac{1}{T} \int_0^T RI^2 dt = \frac{1}{2} RI_m^2 = \frac{1}{2} \frac{\omega^2 \Phi_0^2 R}{R^2 + \omega^2 L^2}$$

4.149 We consider the force \vec{F}_{12} that a circuit 1 exerts on another closed circuit 2 :-

$$\vec{F}_{12} = \oint I_1 d\vec{l}_2 \times \vec{B}_{12}$$

Here \vec{B}_{12} = magnetic field at the site of the current element $d\vec{l}_2$ due to the current I_1 flowing in 1.

$$= \frac{\mu_0}{4\pi} \int \frac{I_1 d\vec{l}_1 \times \vec{r}_{12}}{r_{12}^3}$$

where $\vec{r}_{12} = \vec{r}_2 - \vec{r}_1$ = vector, from current element $d\vec{l}_1$ to the current element $d\vec{l}_2$

Now

$$\vec{F}_{12} = \frac{\mu_0}{4\pi} \iint I_1 I_2 \frac{d\vec{l}_2 \times (d\vec{l}_1 \times \vec{r}_{12})}{r_{12}^3} = \frac{\mu_0}{4\pi} \iint I_1 I_2 \frac{d\vec{l}_1 (d\vec{l}_2 \cdot \vec{r}_{12}) - (d\vec{l}_1 \cdot d\vec{l}_2) \vec{r}_{12}}{r_{12}^3}$$

In the first term, we carry out the integration over $d\vec{l}_2$ first. Then

$$\iint \frac{d\vec{l}_1 (d\vec{l}_2 \cdot \vec{r}_{12})}{r_{12}^3} = \int d\vec{l}_1 \oint \frac{d\vec{l}_2 \cdot \vec{r}_{12}}{r_{12}^3} = - \int d\vec{l}_1 \oint d\vec{l}_2 \cdot \nabla_2 \frac{1}{r_{12}} = 0$$

because
$$\oint d\vec{l}_2 \cdot \nabla_2 \frac{1}{r_{12}} = \int d\vec{S}_2 \text{curl} \left(\nabla \frac{1}{r_{12}} \right) = 0$$

Thus
$$F_{12} = - \frac{\mu_0}{4\pi} \iint I_1 I_2 d\vec{l}_1 \cdot d\vec{l}_2 \frac{\vec{r}_{12}}{r_{12}^3}$$

The integral involved will depend on the vector \vec{a} that defines the separation of the (suitably chosen) centre of the coils. Let C_1 and C_2 be the centres of the two coil suitably defined. Write

$$\vec{r}_{12} = \vec{r}_2 - \vec{r}_1 = \vec{\rho}_2 - \vec{\rho}_1 + \vec{a}$$

where $\vec{\rho}_1$ ($\vec{\rho}_2$) is the distance of $d\vec{l}_1$ ($d\vec{l}_2$) from C_1 (C_2) and \vec{a} stands for the vector $C_1 C_2$.

Then
$$\frac{\vec{r}_{12}}{r_{12}^3} = - \vec{\nabla}_a \frac{1}{r_{12}}$$

and
$$\vec{F}_{12} = \vec{\nabla}_a \left[I_1 I_2 \frac{\mu_0}{4\pi} \iint \frac{d\vec{l}_1 \cdot d\vec{l}_2}{r_{12}} \right]$$

The bracket defines the mutual inductance L_{12} . Thus noting the definition of x

$$\langle F_x \rangle = \frac{\partial L_{12}}{\partial x} \langle I_1 I_2 \rangle$$

where $\langle \rangle$ denotes time average. Now

$$I_1 = I_0 \cos \omega t = \text{Real part of } I_0 e^{i\omega t}$$

The current in the coil 2 satisfies $R I_2 + L_2 \frac{dI_2}{dt} = - L_{12} \frac{dI_1}{dt}$

or
$$I_2 = \frac{-i\omega L_{12}}{R + i\omega L_2} I_0 e^{i\omega t} \text{ (in the complex case)}$$

taking the real part

$$I_2 = - \frac{\omega L_{12} I_0}{R^2 + \omega^2 L_2^2} (\omega L_2 \cos \omega t - R \sin \omega t) = - \frac{\omega L_{12}}{\sqrt{R^2 + \omega^2 L_2^2}} I_0 \cos(\omega t + \varphi)$$

Where $\tan \varphi = \frac{R}{\omega L_2}$. Taking time average, we get

$$\langle F_x \rangle = \frac{\partial L_{12}}{\partial x} I_0 \frac{\omega L_{12} I_0}{\sqrt{R^2 + \omega^2 L_2^2}} \cdot \frac{1}{2} \cos \varphi = \frac{\omega^2 L_2 L_{12} I_0^2}{2(R^2 + \omega^2 L_2^2)} \frac{\partial L_{12}}{\partial x}$$

The repulsive nature of the force is also consistent with Lenz's law, assuming, of course, that L_{12} decreases with x .

4.3 ELASTIC WAVES. ACOUSTICS

4.150 Since the temperature varies linearly we can write the temperature as a function of x , which is, the distance from the point A towards B .

i.e.,
$$T = T_1 + \frac{T_2 - T_1}{l} x, [0 < x < l]$$

hence,
$$dT = \left(\frac{T_2 - T_1}{l} \right) dx \quad (1)$$

In order to travel an elemental distance of dx which is at a distance of x from A it will take a time

$$dt = \frac{dx}{\alpha \sqrt{T}} \quad (2)$$

From Eqns (1) and (2), expressing dx in terms of dT , we get

$$dt = \frac{l}{\alpha \sqrt{T}} \left(\frac{l dT}{T_2 - T_1} \right)$$

Which on integration gives

$$\int_0^t dt = \frac{l}{\alpha (T_2 - T_1)} \int_{T_1}^{T_2} \frac{dT}{\sqrt{T}}$$

or,
$$t = \frac{2l}{(T_2 - T_1)} (\sqrt{T_2} - \sqrt{T_1})$$

Hence the sought time $t = \frac{2l}{\alpha (\sqrt{T_1} + \sqrt{T_2})}$

4.151 Equation of plane wave is given by

$$\xi(r, t) = a \cos(\omega t - \vec{k} \cdot \vec{r}), \text{ where } \vec{k} = \frac{\omega}{v} \hat{n} \text{ called the wave vector}$$

and \hat{n} is the unit vector normal to the wave surface in the direction of the propagation of wave.

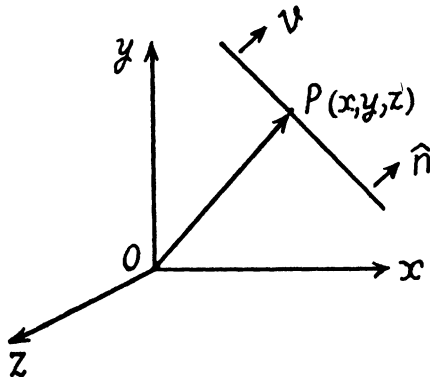

or,
$$\begin{aligned}\xi(x, y, z) &= a \cos(\omega t - k_x x - k_y y - k_z z) \\ &= a \cos(\omega t - k x \cos \alpha - k y \cos \beta - k z \cos \gamma)\end{aligned}$$

Thus
$$\xi(x_1, y_1, z_1, t) = a \cos(\omega t - k x_1 \cos \alpha - k y_1 \cos \beta - k z_1 \cos \gamma)$$

and
$$\xi(x_2, y_2, z_2, t) = a \cos(\omega t - k x_2 \cos \alpha - k y_2 \cos \beta - k z_2 \cos \gamma)$$

Hence the sought wave phase difference

$$\begin{aligned}\varphi_2 - \varphi_1 &= k \left[(x_1 - x_2) \cos \alpha + (y_1 - y_2) \cos \beta + (z_1 - z_2) \cos \gamma \right] \\ \text{or } \Delta \varphi &= |\varphi_2 - \varphi_1| = k \left| \left[(x_1 - x_2) \cos \alpha + (y_1 - y_2) \cos \beta + (z_1 - z_2) \cos \gamma \right] \right| \\ &= \frac{\omega}{v} \left| \left[(x_1 - x_2) \cos \alpha + (y_1 - y_2) \cos \beta + (z_1 - z_2) \cos \gamma \right] \right|\end{aligned}$$

4.152 The phase of the oscillation can be written as

$$\Phi = \omega t - \vec{k} \cdot \vec{r}$$

When the wave moves along the x -axis

$$\Phi = \omega t - k_x x \quad (\text{On putting } k_y = k_z = 0).$$

Since the velocity associated with this wave is v_1

We have
$$k_x = \frac{\omega}{v_1}$$

Similarly
$$k_y = \frac{\omega}{v_2} \quad \text{and} \quad k_z = \frac{\omega}{v_3}$$

Thus
$$\vec{k} = \frac{\omega}{v_1} \hat{e}_x + \frac{\omega}{v_2} \hat{e}_y + \frac{\omega}{v_3} \hat{e}_z.$$

4.153 The wave equation propagating in the direction of +ve x axis in medium K is given as

$$\xi = a \cos(\omega t - kx)$$

So,
$$\xi = a \cos k(vt - x), \quad \text{where } k = \frac{\omega}{v} \quad \text{and } v \text{ is the wave velocity}$$

In the reference frame K' , the wave velocity will be $(v - V)$ propagating in the direction of +ve x axis and x will be x' . Thus the sought wave equation.

$$\xi = a \cos k[(v - V)t - x']$$

or,
$$\xi = a \cos \left[\left(\omega - \frac{\omega}{v} V \right) t - kx' \right] = a \cos \left[\omega t \left(1 - \frac{V}{v} \right) - kx' \right]$$

4.154 This follows on actually putting

$$\xi = f(t + \alpha x)$$

in the wave equation
$$\frac{\partial^2 \xi}{\partial x^2} = \frac{1}{v^2} \frac{\partial^2 \xi}{\partial t^2}$$

(We have written the one dimensional form of the wave equation.) Then

$$\frac{1}{v^2} f''(t + \alpha x) = \alpha^2 f''(t + \alpha x)$$

so the wave equation is satisfied if

$$\alpha = \pm \frac{1}{v'}$$

That is the physical meaning of the constant α .

4.155 The given wave equation

$$\xi = 60 \cos(1800t - 5.3x)$$

is of the type

$$\xi = a \cos(\omega t - kx), \text{ where } a = 60 \times 10^{-6} \text{ m}$$

$$\omega = 1800 \text{ per sec and } k = 5.3 \text{ per metre}$$

As $k = \frac{2\pi}{\lambda}$, so $\lambda = \frac{2\pi}{k}$

and also $k = \frac{\omega}{v}$, so $v = \frac{\omega}{k} = 340 \text{ m/s}$

(a) Sought ratio = $\frac{a}{\lambda} = \frac{ak}{2\pi} = 5.1 \times 10^{-5}$

(b) Since $\xi = a \cos(\omega t - kx)$

$$\frac{\partial \xi}{\partial t} = -a\omega \sin(\omega t - kx)$$

So velocity oscillation amplitude

$$\left(\frac{\partial \xi}{\partial t}\right)_m \text{ or } v_m = a\omega = 0.11 \text{ m/s} \quad (1)$$

and the sought ratio of velocity oscillation amplitude to the wave propagation velocity

$$= \frac{v_m}{v} = \frac{0.11}{340} = 3.2 \times 10^{-4}$$

(c) Relative deformation = $\frac{\partial \xi}{\partial x} = ak \sin(\omega t - kx)$

So, relative deformation amplitude

$$= \left(\frac{\partial \xi}{\partial x}\right)_m = ak = (60 \times 10^{-6} \times 5.3) \text{ m} = 3.2 \times 10^{-4} \text{ m} \quad (2)$$

From Eqns (1) and (2)

$$\left(\frac{\partial \xi}{\partial x}\right)_m = ak = \frac{a\omega}{v} = \frac{1}{v} \left(\frac{\partial \xi}{\partial t}\right)_m$$

Thus $\left(\frac{\partial \xi}{\partial x}\right)_m = \frac{1}{v} \left(\frac{\partial \xi}{\partial t}\right)_m$, where $v = 340 \text{ m/s}$ is the wave velocity.

4.156 (a) The given equation is,

$$\xi = a \cos(\omega t - kx)$$

So at

$$t = 0,$$

$$\xi = a \cos kx$$

Now,

$$\frac{d\xi}{dt} = -a\omega \sin(\omega t - kx)$$

and

$$\frac{d\xi}{dt} = a\omega \sin kx, \text{ at } t = 0.$$

Also,

$$\frac{d\xi}{dx} = +ak \sin(\omega t - kx)$$

and at

$$t = 0,$$

$$\frac{d\xi}{dx} = -ak \sin kx.$$

Hence all the graphs are similar having different amplitudes, as shown in the answer-sheet of the problem book.

- (b) At the points, where $\xi = 0$, the velocity direction is positive, i.e., along +ve x -axis in the case of longitudinal and +ve y -axis in the case of transverse waves, where $\frac{d\xi}{dt}$ is positive and vice versa.

For sought plots see the answer-sheet of the problem book.

4.157 In the given wave equation the particle's displacement amplitude = $a e^{-\gamma x}$

Let two points x_1 and x_2 , between which the displacement amplitude differ by $\eta = 1\%$

So,

$$a e^{-\gamma x_1} - a e^{-\gamma x_2} = \eta a e^{-\gamma x_1}$$

or

$$e^{-\gamma x_1} (1 - \eta) = e^{-\gamma x_2}$$

or

$$\ln(1 - \eta) - \gamma x_1 = -\gamma x_2$$

or,

$$x_2 - x_1 = -\frac{\ln(1 - \eta)}{\gamma}$$

So path difference = $-\frac{\ln(1 - \eta)}{\gamma}$

and phase difference = $\frac{2\pi}{\lambda} \times \text{path difference}$

$$= -\frac{2\pi \ln(1 - \eta)}{\lambda \gamma} = \frac{2\pi \eta}{\lambda \cdot \gamma} = 0.3 \text{ rad}$$

4.158 Let S be the source whose position vector relative to the reference point O is \vec{r} . Since intensities are inversely proportional to the square of distances,

$$\frac{\text{Intensity at } P (I_1)}{\text{Intensity at } Q (I_2)} = \frac{d_2^2}{d_1^2}$$

where $d_1 = PS$ and $d_2 = QS$.

But intensity is proportional to the square of amplitude.

$$\text{So, } \frac{a_1^2}{a_2^2} = \frac{d_2^2}{d_1^2} \text{ or } a_1 d_1 = a_2 d_2 = k \text{ (say)}$$

$$\text{Thus } d_1 = \frac{k}{a_1} \text{ and } d_2 = \frac{k}{a_2}$$

Let \hat{n} be the unit vector along PQ directed from P to Q .

$$\text{Then } \vec{PS} = d_1 \hat{n} = \frac{k}{a_1} \hat{n} \quad \vec{r}_1 \quad \vec{r} \quad \vec{r}_2$$

$$\text{and } \vec{SQ} = d_2 \hat{n} = \frac{k}{a_2} \hat{n}$$

From the triangle law of vector addition.

$$\vec{OP} + \vec{PS} = \vec{OS} \quad \text{or } \vec{r}_1 + \frac{k}{a_1} \hat{n} = \vec{r}$$

$$\text{or } a_1 \vec{r}_1 + k \hat{n} = a_1 \vec{r} \quad (1)$$

$$\text{Similarly } \vec{r} + \frac{k}{a_2} \hat{n} = \vec{r}_2 \quad \text{or } a_2 \vec{r}_2 - k \hat{n} = a_2 \vec{r} \quad (2)$$

Adding (1) and (2),

$$a_1 \vec{r}_1 + a_2 \vec{r}_2 = (a_1 - a_2) \vec{r}$$

$$\text{Hence } \vec{r} = \frac{a_1 \vec{r}_1 + a_2 \vec{r}_2}{a_1 + a_2}$$

4.159 (a) We know that the equation of a spherical wave in a homogeneous absorbing medium of wave damping coefficient γ is :

$$\xi = \frac{a'_0 e^{-\gamma r}}{r} \cos(\omega t - kr)$$

Thus particle's displacement amplitude equals

$$\frac{a'_0 e^{-\gamma r}}{r}$$

According to the conditions of the problem,

$$\text{at } r = r_0, a_0 = \frac{a'_0 e^{-\gamma r_0}}{r_0} \quad (1)$$

$$\text{and when } r = r, \frac{a_0}{\eta} = \frac{a'_0 e^{-\gamma r}}{r} \quad (2)$$

Thus from Eqns (1) and (2)

$$e^{\gamma(r-r_0)} = \eta \frac{r_0}{r}$$

or,
$$\gamma(r-r_0) = \ln(\eta r_0) - \ln r$$

or,
$$\gamma = \frac{\ln \eta + \ln r_0 - \ln r}{r - r_0} = \frac{\ln 3 + \ln 5 - \ln 10}{5} = 0.08 \text{ m}^{-1}$$

(b) As
$$\xi = \frac{a'_0 e^{-\gamma r}}{r} \cos(\omega t - kr)$$

So,
$$\frac{\partial \xi}{\partial t} = -\frac{a'_0 e^{-\gamma r}}{r} \omega \sin(\omega t - kr)$$

$$\left(\frac{\partial \xi}{\partial t}\right)_n = \frac{a'_0 e^{-\gamma r}}{r} \omega$$

But at point A,
$$\frac{a'_0 e^{-\gamma r}}{r} = \frac{a_0}{\eta}$$

So,
$$\left(\frac{\partial \xi}{\partial t}\right)_m = \frac{a_0 \omega}{\eta} = \frac{a_0 2\pi}{\eta} = \frac{50 \times 10^{-6}}{3} \times 2 \times \frac{22}{7} \times 1.45 \times 10^3 = 15 \text{ m/s}$$

4.160 (a) Equation of the resultant wave,

$$\begin{aligned} \xi &= \xi_1 + \xi_2 = 2a \cos k \left(\frac{y-x}{2} \right) \cos \left\{ \omega t - \frac{k(x+y)}{2} \right\}, \\ &= a' \cos \left\{ \omega t - \frac{k(x+y)}{2} \right\}, \text{ where } a' = 2a \cos k' \left(\frac{y-x}{2} \right) \end{aligned}$$

Now, the equation of wave pattern is,

$$x + y = k, \text{ (a Const.)}$$

For sought plots see the answer-sheet of the problem book.

For antinodes, i.e. maximum intensity

$$\cos \frac{k(y-x)}{2} = \pm 1 = \cos n\pi$$

or,
$$\pm (x-y) = \frac{2n\pi}{k} = n\lambda$$

or,
$$y = x \pm n\lambda, n = 0, 1, 2, \dots$$

Hence, the particles of the medium at the points, lying on the solid straight lines ($y = x \pm n\lambda$), oscillate with maximum amplitude.

For nodes, i.e. minimum intensity,

$$\cos \frac{k(y-x)}{2} = 0$$

or,
$$\pm \frac{k(y-x)}{2} = (2n+1) \frac{\pi}{2}$$

or,
$$y = x \pm (2n + 1)\lambda/2,$$

and hence the particles at the points, lying on dotted lines do not oscillate.

(b) When the waves are longitudinal,

For sought plots see the answer-sheet of the problem book.

$$\begin{aligned}
 k(y-x) &= \cos^{-1} \frac{\xi_1}{a} - \cos^{-1} \frac{\xi_2}{a} \\
 \text{or, } \frac{\xi_1}{a} &= \cos \left\{ k(y-x) + \cos^{-1} \frac{\xi_2}{a} \right\} \\
 &= \frac{\xi_2}{a} \cos k(y-x) - \sin k(y-x) \sin \left(\cos^{-1} \frac{\xi_2}{a} \right) \\
 &= \frac{\xi_2}{a} \cos k(y-x) - \sin k(y-x) \sqrt{1 - \frac{\xi_2^2}{a^2}} \quad (1)
 \end{aligned}$$

from (1),

if
$$\sin k(y-x) = 0 \quad \sin(n\pi)$$

$$\xi_1 = \xi_2 (-1)^n$$

thus, the particles of the medium at the points lying on the straight lines, $y = x \pm \frac{n\lambda}{2}$ will oscillate along those lines (even n), or at right angles to them (odd n).

Also from (1),

if
$$\cos k(y-x) = 0 = \cos(2n+1)\frac{\pi}{2}$$

$$\frac{\xi_1^2}{a^2} = 1 - \xi_2^2/a^2, \text{ a circle.}$$

Thus the particles, at the points, where $y = x \pm (n \pm 1/4)\lambda$, will oscillate along circles. In general, all other particles will move along ellipses.

4.161 The displacement of oscillations is given by $\xi = a \cos(\omega t - kx)$

Without loss of generality, we confine ourselves to $x = 0$. Then the displacement maxima occur at $\omega t = n\pi$. Concentrate at $\omega t = 0$. Now the energy density is given by

$$w = \rho a^2 \omega^2 \sin^2 \omega t \quad \text{at } x = 0$$

$T/6$ time later (where $T = \frac{2\pi}{\omega}$ is the time period) than $t = 0$.

$$w = \rho a^2 \omega^2 \sin^2 \frac{\pi}{3} = \frac{3}{4} \rho a^2 \omega^2 = w_0$$

Thus
$$\langle w \rangle = \frac{1}{2} \rho a^2 \omega^2 = \frac{2w_0}{3}.$$

4.162 The power output of the source much be

$$4 \pi I^2 I_0 = Q \text{ Watt.}$$

The required flux of acoustic power is then : $Q = \frac{\Omega}{4 \pi}$

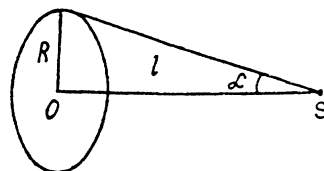

Where Ω is the solid angle subtended by the disc enclosed by the ring at S . This solid angle is

$$\Omega = 2 \pi (1 - \cos \alpha)$$

So flux

$$\Phi = I_0 I_0 \left(1 - \frac{l}{\sqrt{l^2 + R^2}}\right) 2\pi l^2$$

Substitution gives $\Phi = 2 \Pi \times 30 \left(1 - \frac{l}{\sqrt{l^2 + \frac{1}{4}}}\right) \mu\text{W} = 1.99 \mu\text{W}$.

Eqn. (1) is a well known result stich is derived as follows; Let SO be the polar axis. Then the required solid angle is the area of that part of the surface a sphere of much radius whose colatitude is $\leq \alpha$.

Thus

$$\Omega = \int_0^\alpha 2 \pi \sin \theta d\theta = 2 \pi (1 - \cos \alpha).$$

4.163 From the result of 4.162 power flowing out through anyone of the opening

$$\begin{aligned} &= \frac{P}{2} \left(1 - \frac{h/2}{\sqrt{R^2 + (h/2)^2}}\right) \\ &= \frac{P}{2} \left(1 - \frac{h}{\sqrt{4R^2 + h^2}}\right) \end{aligned}$$

As total power output equals P , so the power reaching the lateral surface must be.

$$= P - 2 \cdot \frac{P}{2} \left(1 - \frac{h}{\sqrt{4R^2 + h^2}}\right) = \frac{Ph}{\sqrt{4R^2 + h^2}} = 0.07W$$

4.164 We are given

$$\xi = a \cos kx \omega t$$

so $\frac{\partial \xi}{\partial x} = -a k \sin kx \cos \omega t$ and $\frac{\partial \xi}{\partial t} = -a \omega \cos kx \sin \omega t$

Thus

$$\begin{aligned} (\xi)_{t=0} &= a \cos kx, \quad (\xi)_{t=T/2} = -a \cos kx \\ \left(\frac{\partial \xi}{\partial x}\right)_{t=0} &= -a k \sin kx, \quad \left(\frac{\partial \xi}{\partial x}\right)_{t=T/2} = a k \sin kx \end{aligned}$$

(a) The graphs of (ξ) and $\left(\frac{\partial \xi}{\partial x}\right)$ are as shown in Fig. (35) of the book (p.332).

(b) We can calculate the density as follows :

Take a parallelepiped of cross section unity and length dx with its edges at x and $x + dx$.

After the oscillation the edge at x goes to $x + \xi(x)$ and the edge at $x + dx$ goes to $x + dx + \xi(x + dx)$

$= x + dx + \xi(x) + \frac{\partial \xi}{\partial x} dx$. Thus the volume of the element (originally dx) becomes

$$\left(1 + \frac{\partial \xi}{\partial x}\right) dx$$

and hence the density becomes $\rho = \frac{\rho_0}{1 + \frac{\partial \xi}{\partial x}}$.

On substituting we get for the density $\rho(x)$ the curves shown in Fig.(35). referred to above.

(c) The velocity $v(x)$ at time $t = T/4$ is

$$\left(\frac{\partial \xi}{\partial t}\right)_{t = T/4} = -a \omega \cos kx$$

On plotting we get the figure (36).

4.165 Given $\xi = a \cos kx \cos \omega t$

(a) The potential energy density (per unit volume) is the energy of longitudinal strain. This is

$$w_p = \left(\frac{1}{2} \text{stress} \times \text{strain}\right) = \frac{1}{2} E \left(\frac{\partial \xi}{\partial x}\right)^2, \quad \left(\frac{\partial \xi}{\partial x} \text{ is the longitudinal strain}\right)$$

$$w_p = \frac{1}{2} E a^2 k^2 \sin^2 kx \cos^2 \omega t$$

But $\frac{\omega^2}{k^2} = \frac{E}{\rho}$ or $E k^2 = \rho \omega^2$

Thus $w_p = \frac{1}{2} \rho a^2 \omega^2 \sin^2 kx \cos^2 \omega t$

(b) The kinetic energy density is

$$= \frac{1}{2} \rho \left(\frac{\partial \xi}{\partial t}\right)^2 = \frac{1}{2} \rho a^2 \omega^2 \cos^2 kx \sin^2 \omega t.$$

On plotting we get Fig. 37 given in the book (p. 332). For example at $t = 0$

$$w = w_p + w_k = \frac{1}{2} \rho a^2 \omega^2 \sin^2 kx$$

and the displacement nodes are at $x = \pm \frac{\pi}{2k}$ so we do get the figure.

4.166 Let us denote the displacement of the elements of the string by

$$\xi = a \sin kx \cos \omega t$$

since the string is 120 cm long we must have $k \cdot 120 = n \pi$

If x_1 is the distance at which the displacement amplitude first equals 3.5 mm then

$$a \sin kx_1 = 3.5 = a \sin (kx_1 + 15k)$$

Then $kx_1 + 15k = \pi - kx_1$ or $kx_1 = \frac{\pi - 15k}{2}$

One can convince oneself that the string has the form shown below

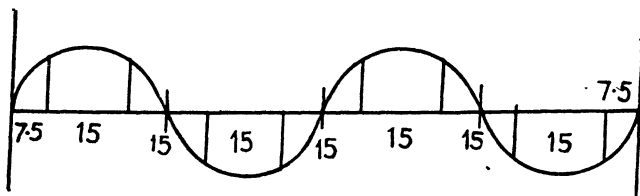

It shows that $k \times 120 = 4\pi$, so $k = \frac{\pi}{30} \text{ cm}^{-1}$

Thus we are dealing with the third overtone

Also $kx_1 = \frac{\pi}{4}$ so $a = 3.5 \sqrt{2} \text{ mm} = 4.949 \text{ mm}$.

4.167 We have $n = \frac{1}{2l} \sqrt{\frac{T}{m}} = \frac{1}{2l} \sqrt{\frac{Tl}{M}}$ Where M = total mass of the wire. When the wire is stretched, total mass of the wire remains constant. For the first wire the new length = $l + \eta_1 l$ and for the second wire, the length is $l + \eta_2 l$. Also $T_1 = \alpha (\eta_1 l)$ where α is a constant and $T_2 = \alpha (\eta_2 l)$. Substituting in the above formula.

$$v_1 = \frac{1}{2(l + \eta_1 l)} \sqrt{\frac{(\alpha \eta_1 l)(l + \eta_1 l)}{M}}$$

$$v_2 = \frac{1}{2(l + \eta_2 l)} \sqrt{\frac{(\alpha \eta_2 l)(l + \eta_2 l)}{M}}$$

$$\therefore \frac{v_2}{v_1} = \frac{1 + \eta_1}{1 + \eta_2} \sqrt{\frac{\eta_2 (1 + \eta_2)}{\eta_1 (1 + \eta_1)}}$$

$$\frac{v_2}{v_1} = \sqrt{\frac{\eta_2 (1 + \eta_1)}{\eta_1 (1 + \eta_2)}} = \sqrt{\frac{0.04 (1 + 0.02)}{0.02 (1 + 0.04)}} = 1.4$$

4.168 Let initial length and tension be l and T respectively.

So,
$$v_1 = \frac{1}{2l} \sqrt{\frac{T}{\rho_1}}$$

In accordance with the problem, the new length

$$l' = l - \frac{l \times 35}{100} = 0.65 l$$

and new tension, $T' = T + \frac{T \times 70}{100} = 1.7 T$

Thus the new frequency

$$v_2 = \frac{1}{2l'} \sqrt{\frac{T'}{\rho_1}} = \frac{1}{2 \times 0.65 l} \sqrt{\frac{1.7 T}{\rho_1}}$$

Hence
$$\frac{v_2}{v_1} = \frac{\sqrt{1.7}}{0.65} = \frac{1.3}{0.65} = 2$$

4.169 Obviously in this case the velocity of sound propagation

$$v = 2v(l_2 - l_1)$$

where l_2 and l_1 are consecutive lengths at which resonance occur

In our problem, $(l_2 - l_1) = l$

So
$$v = 2vl = 2 \times 2000 \times 8.5 \text{ cm/s} = 0.34 \text{ km/s.}$$

4.170 (a) When the tube is closed at one end

$$v = \frac{v}{4l} (2n+1), \text{ where } n = 0, 1, 2, \dots$$

$$= \frac{340}{4 \times 0.85} (2n+1) = 100 (2n+1)$$

Thus for $n = 0, 1, 2, 3, 4, 5, 6, \dots$, we get

$$n_1 = 100 \text{ Hz}, n_2 = 300 \text{ Hz}, n_3 = 500 \text{ Hz}, n_4 = 700 \text{ Hz},$$

$$n_5 = 900 \text{ Hz}, n_6 = 1100 \text{ Hz}, n_7 = 1300 \text{ Hz}$$

Since v should be $< v_0 = 1250 \text{ Hz}$, we need not go beyond n_6 .

Thus 6 natural oscillations are possible.

(b) Organ pipe opened from both ends vibrates with all harmonics of the fundamental frequency. Now, the fundamental mode frequency is given as

$$v = v/\lambda$$

or,
$$v = v/2l$$

Here, also, end correction has been neglected. So, the frequencies of higher modes of vibrations are given by

$$v = n(v/2l) \tag{1}$$

or, $v_1 = v/2l$, $v_2 = 2(v/2l)$, $v_3 = 3(v/2l)$

It may be checked by putting the values of n in the equation (1) that below 1285 Hz, there are a total of six possible natural oscillation frequencies of air column in the open pipe.

4.171 Since the copper rod is clamped at mid point, it becomes a mode and the two free ends will be antinodes. Thus the fundamental mode formed in the rod is as shown in the Fig. (a).

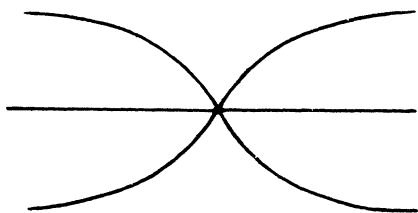

4.171 (a)

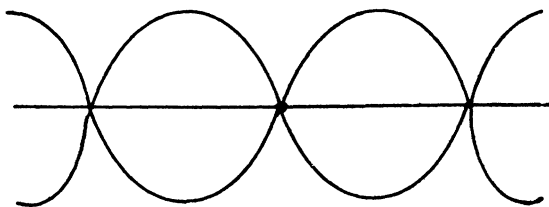

4.171 (b)

In this case,

$$l = \frac{\lambda}{2}$$

So,

$$v_0 = \frac{v}{2l} = \frac{1}{2l} \sqrt{\frac{E}{\rho}} \sqrt{\frac{E}{e}}$$

where E = Young's modulus and ρ is the density of the copper

Similarly the second mode or the first overtone in the rod is as shown above in Fig. (b).

Here

$$l = \frac{3\lambda}{2}$$

Hence

$$v_1 = \frac{3v}{2l} = \frac{3}{2l} \sqrt{\frac{E}{\rho}}$$

$$v = \frac{2n+1}{2l} \sqrt{\frac{E}{\rho}} \text{ where } n = 0, 1, 2 \dots$$

Putting the given values of E and ρ in the general equation

$$v = 3.8(2n+1) \text{ kHz}$$

Hence $v_0 = 3.8 \text{ kHz}$, $v_1 = (3.8 \times 3) \text{ kHz}$, $v_2 = (3.8) \times 5 = 19 \text{ kHz}$,

$v_3 = (3.8 \times 7) = 26.6 \text{ kHz}$, $v_4 = (3.8 \times 9) = 34.2 \text{ kHz}$,

$v_5 = (3.8 \times 11) = 41.8 \text{ kHz}$, $v_6 = (3.8) \times 13 \text{ kHz} = 49.4 \text{ kHz}$ and

$v_7 = (3.8) \times 14 \text{ kHz} > 50 \text{ kHz}$.

Hence the sought number of frequencies between 20 to 50 kHz equals 4.

4.172 Let two waves $\xi_1 = a \cos(\omega t - kx)$ and $\xi_2 = a \cos(\omega t + kx)$, superpose and as a result, we have a standing wave (the resultant wave) in the string of the form $\xi = 2a \cos kx \cos \omega t$.

According to the problem $2a = a_m$.

Hence the standing wave excited in the string is

$$\xi = a_m \cos kx \cos \omega t \quad (1)$$

or,
$$\frac{\partial \xi}{\partial t} = -\omega a_m \cos kx \sin \omega t \quad (2)$$

So the kinetic energy confined in the string element of length dx , is given by :

$$dT = \frac{1}{2} \left(\frac{m}{l} dx \right) \left(\frac{\partial \xi}{\partial t} \right)^2$$

or,
$$dT = \frac{1}{2} \left(\frac{m}{l} dx \right) a_m^2 \omega^2 \cos^2 kx \sin^2 \omega t$$

or,
$$dT = \frac{m a_m^2 \omega^2}{2l} \sin^2 \omega t \cos^2 \frac{2\pi}{\lambda} x dx$$

Hence the kinetic energy confined in the string corresponding to the fundamental tone

$$T = \int dT = \frac{m a_m^2 \omega^2}{2l} \sin^2 \omega t \int_0^{\lambda/2} \cos^2 \frac{2\pi}{\lambda} x dx$$

Because, for the fundamental tone, length of the string $l = \frac{\lambda}{2}$

Integrating we get,
$$T = \frac{1}{4} m a_m^2 \omega^2 \sin^2 \omega t$$

Hence the sought maximum kinetic energy equals, $T_{\max} = \frac{1}{4} m a_m^2 \omega^2$,

because for T_{\max} , $\sin^2 \omega t = 1$

(ii) Mean kinetic energy averaged over one oscillation period

$$\langle T \rangle = \frac{\int T dt}{\int dt} = \frac{1}{4} m a_m^2 \omega^2 \frac{\int_0^{2\pi/\omega} \sin^2 \omega t dt}{\int_0^{2\pi/\omega} dt}$$

or,
$$\langle T \rangle = \frac{1}{8} m a_m^2 \omega^2 .$$

4.173 We have a standing wave given by the equation

$$\xi = a \sin kx \cos \omega t$$

So,
$$\frac{\partial \xi}{\partial t} = -a \omega \sin kx \sin \omega t \quad (1)$$

and
$$\frac{\partial \xi}{\partial x} = a k \cos kx \cos \omega t \quad (2)$$

The kinetic energy confined in an element of length dx of the rod

$$dT = \frac{1}{2} (\rho S dx) \left(\frac{\partial \xi}{\partial t} \right)^2 = \frac{1}{2} \rho S a^2 \omega^2 \sin^2 \omega t \sin^2 kx dx$$

So total kinetic energy confined into rod

$$T = \int dT = \frac{1}{2} \rho S a^2 \omega^2 \sin^2 \omega t \int_0^{\lambda/2} \sin^2 \frac{2\pi}{\lambda} x dx$$

$$\text{or,} \quad T = \frac{\pi S a^2 \omega^2 \rho \sin^2 \omega t}{4k} \quad (3)$$

The potential energy in the above rod element

$$dU = \int \partial U = - \int_0^{\xi} F_{\xi} d\xi, \text{ where } F_{\xi} = (\rho S dx) \frac{\partial^2 \xi}{\partial t^2}$$

$$\text{or,} \quad F_{\xi} = - (\rho S dx) \omega^2 \xi$$

$$\text{so,} \quad dU = \omega^2 \rho S dx \int_0^{\xi} \xi d\xi$$

$$\text{or,} \quad dU = \frac{\rho \omega^2 S \xi^2}{2} dx = \frac{\rho \omega^2 S a^2 \cos^2 \omega t \sin^2 kx dx}{2}$$

Thus the total potential energy stored in the rod $U = \int dU$

$$\text{or,} \quad U = \rho \omega^2 S a^2 \cos^2 \omega t \int_0^{\lambda/2} \sin^2 \frac{2\pi}{\lambda} x dx$$

$$\text{So,} \quad U = \frac{\pi \rho S a^2 \omega^2 \cos^2 \omega t}{4k}$$

To find the potential energy stored in the rod element we may adopt an easier way. We know that the potential energy density confined in a rod under elastic force equals :

$$\begin{aligned} U_D &= \frac{1}{2} (\text{stress} \times \text{strain}) = \frac{1}{2} \sigma \epsilon = \frac{1}{2} Y \epsilon^2 \\ &= \frac{1}{2} \rho v^2 \epsilon^2 = \frac{1}{2} \frac{\rho \omega^2}{k^2} \epsilon^2 \\ &= \frac{1}{2} \frac{\rho \omega^2}{k^2} \left(\frac{\partial \xi}{\partial x} \right)^2 = \frac{1}{2} \rho a^2 \omega^2 \cos^2 \omega t \cos^2 kx \end{aligned}$$

Hence the total potential energy stored in the rod

$$\begin{aligned}
 U &= \int U_D dV = \int_0^{\lambda/2} \frac{1}{2} \rho a^2 \omega^2 \cos^2 \omega t \cos^2 kx S dx \\
 &= \frac{\pi \rho S a^2 \omega^2 \cos^2 \omega t}{4k} \quad (4)
 \end{aligned}$$

Hence the sought mechanical energy confined in the rod between the two adjacent nodes

$$E = T + U = \frac{\pi \rho \omega^2 a^2 S}{4k}.$$

- 4.174 Receiver R_1 registers the beating, due to the sound waves reaching directly to it from source and the other due to the reflection from the wall.

Frequency of sound reaching directly from S to R_1

$$v_{S \rightarrow R_1} = v_0 \frac{v}{v - u} \text{ when } S \text{ moves towards } R_1$$

and $v'_{S \rightarrow R_1} = v_0 \frac{v}{v + u}$ when S moves towards the wall

Now frequency reaching to R_1 after reflection from wall

$$v_{W \rightarrow R_1} = v_0 \frac{v}{v + u}, \text{ when } S \text{ moves towards } R_1$$

and $v'_{W \rightarrow R_1} = v_0 \frac{v}{v - u}$, when S moves towards the wall

Thus the sought beat frequency

$$\begin{aligned}
 \Delta v &= (v_{S \rightarrow R_1} - v_{W \rightarrow R_1}) \text{ or } (v'_{W \rightarrow R_1} - v_{S \rightarrow R_1}) \\
 &= v_0 \frac{v}{v - u} - v_0 \frac{v}{v + u} = \frac{2 v_0 v u}{v^2 - u^2} \approx \frac{2 u v_0}{v} = 1 \text{ Hz}
 \end{aligned}$$

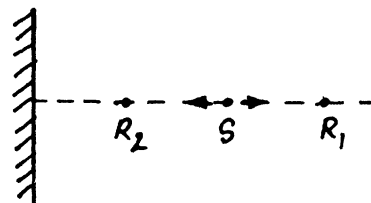

- 4.175 Let the velocity of tuning fork is u . Thus frequency reaching to the observer due to the tuning fork that approaches the observer

$$v' = v_0 \frac{v}{v - u} \quad [v = \text{velocity of sound}]$$

Frequency reaching the observer due to the tuning fork that recedes from the observer

$$v'' = v_0 \frac{v}{v + u}$$

So, Beat frequency $v - v'' = v = v_0 v \left(\frac{1}{v - u} - \frac{1}{v + u} \right)$

$$\text{or, } v = \frac{2 v_0 v u}{v^2 - u^2}$$

$$\text{So, } v u^2 + (2 v v_0) u - v^2 v = 0$$

Hence
$$u = \frac{-2v v_0 \pm \sqrt{4v_0^2 v^2 + 4v^2 v^2}}{2v}$$

Hence the sought value of u , on simplifying and noting that $u > 0$

$$u = \frac{v v_0}{v} \left(\sqrt{1 + \left(\frac{v}{v_0}\right)^2} - 1 \right)$$

4.176 Obviously the maximum frequency will be heard when the source is moving with maximum velocity towards the receiver and minimum frequency will be heard when the source recedes with maximum velocity. As the source swing harmonically its maximum velocity equals $a\omega$. Hence

$$v_{\max} = v_0 \frac{v}{v - a\omega} \quad \text{and} \quad v_{\min} = v_0 \frac{v}{v + a\omega}$$

So the frequency band width $\Delta v = v_{\max} - v_{\min} = v_0 v \left(\frac{2a\omega}{v^2 - a^2\omega^2} \right)$

or,
$$(\Delta v a^2)\omega^2 + (2v_0 v a)\omega - \Delta v v^2 = 0$$

So,
$$\omega = \frac{-2v_0 v a \pm \sqrt{4v_0^2 v^2 a^2 + \Delta v^2 a^2 v^2}}{2\Delta v a^2}$$

On simplifying (and taking + sign as $\omega \rightarrow 0$ if $\Delta v \rightarrow 0$)

$$\omega = \frac{v v_0}{\Delta v a} \left(\sqrt{1 + \left(\frac{\Delta v}{v_0}\right)^2} - 1 \right)$$

4.177 It should be noted that the frequency emitted by the source at time t could not be received at the same moment by the receiver, because till that time the source will cover the distance $\frac{1}{2} w t^2$ and the sound wave will take the further time $\frac{1}{2} w t^2 / v$ to reach the receiver. Therefore the frequency noted by the receiver at time t should be emitted by the source at the time $t_1 < t$. Therefore

$$t_1 + \left(\frac{1}{2} w t_1^2 / v \right) = t \quad (1)$$

and the frequency noted by the receiver

$$v = v_0 \frac{v}{v + w t_1} \quad (2)$$

Solving Eqns (1) and (2), we get

$$v = \frac{v_0}{\sqrt{1 + \frac{2 w t}{v}}} = 1.35 \text{ kHz.}$$

- 4.178 (a) When the observer receives the sound, the source is closest to him. It means, that frequency is emitted by the source sometimes before (Fig.) Figure shows that the source approaches the stationary observer with velocity $v_s \cos \theta$.

Hence the frequency noted by the observer

$$v = v_0 \left(\frac{v}{v - v_s \cos \theta} \right)$$

$$= v_0 \left(\frac{v}{v - \eta v \cos \theta} \right) = \frac{v_0}{1 - \eta \cos \theta} \quad (1)$$

But $\frac{x}{v_s} = \frac{\sqrt{l^2 + x^2}}{v}$, So, $\frac{x}{\sqrt{l^2 + x^2}} = \frac{v_s}{v} = \eta$

or, $\cos \theta = \eta$ (2)

Hence from Eqns. (1) and (2) the sought frequency

$$v = \frac{v_0}{1 - \eta^2} = 5 \text{ kHz}$$

- (b) When the source is right in front of O , the sound emitted by it will not be Doppler shifted because $\theta = 90^\circ$. This sound will be received at O at time $t = \frac{l}{v}$ after the source has passed it. The source will by then have moved ahead by a distance $v_s t = l \eta$. The distance between the source and the observer at this time will be $l \sqrt{1 + \eta^2} = 0.32 \text{ km}$.

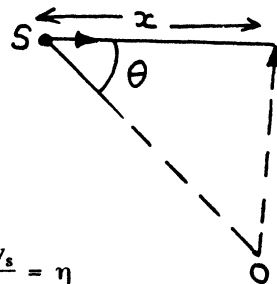

- 4.179 Frequency of sound when it reaches the wall

$$v' = v \frac{v + u}{v}$$

wall will reflect the sound with same frequency v' . Thus frequency noticed by a stationary observer after reflection from wall

$$v'' = v' \frac{v}{v - u}, \text{ since wall behaves as a source of frequency } v'.$$

Thus,
$$v'' = v \frac{v + u}{v} \cdot \frac{v}{v - u} = v \frac{v + u}{v - u}$$

or,
$$\lambda'' = \lambda \frac{v - u}{v + u} \quad \text{or} \quad \frac{\lambda''}{\lambda} = \frac{v - u}{v + u}$$

So,
$$1 - \frac{\lambda''}{\lambda} = 1 - \frac{v - u}{v + u} = \frac{2u}{v + u}$$

Hence the sought percentage change in wavelength

$$= \frac{\lambda - \lambda''}{\lambda} \times 100 = \frac{2u}{v + u} \times 100 \% = 0.2\% \text{ decrease.}$$

4.180 Frequency of sound reaching the wall.

$$v = v_0 \left(\frac{v - u}{v} \right) \quad (1)$$

Now for the observer the wall becomes a source of frequency v receding from it with velocity u

Thus, the frequency reaching the observer

$$v' = v \left(\frac{v}{v + u} \right) = v_0 \left(\frac{v - u}{v + u} \right) \quad [\text{Using (1)}]$$

Hence the beat frequency registered by the receiver (observer)

$$\Delta v = v_0 - v' = \frac{2u v_0}{v + u} = 0.6 \text{ Hz.}$$

4.181 Intensity of a spherical sound wave emitted from a point source in a homogeneous absorbing medium of wave damping coefficient γ is given by

$$I = \frac{1}{2} \rho a^2 e^{-2\gamma r} \omega^2 v$$

So, Intensity of sound at a distance r_1 from the source

$$= \frac{I_1}{r_1^2} = \frac{1/2 \rho a^2 e^{-2\gamma r_1} \omega^2 v}{r_1^2}$$

and intensity of sound at a distance r_2 from the source

$$= I_2/r_2^2 = \frac{1/2 \rho a^2 e^{-2\gamma r_2} \omega^2 v}{r_2^2}$$

But according to the problem

$$\frac{1}{\eta} \frac{I_1}{r_1^2} = \frac{I_2}{r_2^2}$$

So,
$$\frac{\eta r_1^2}{r_2^2} = e^{2\gamma(r_2 - r_1)} \quad \text{or} \quad \ln \frac{\eta r_2^2}{r_1^2} = 2\gamma(r_2 - r_1)$$

or,
$$\gamma = \frac{\ln(\eta r_2^2/r_1^2)}{2(r_2 - r_1)} = 6 \times 10^{-3} \text{ m}^{-1}$$

4.182 (a) Loudness level in bells = $\log \frac{I}{I_0}$. (I_0 is the threshold of audibility.)

So, loudness level in decibells, $L = 10 \log \frac{I}{I_0}$

Thus loudness level at $x = x_1 = L_{x_1} = 10 \log \frac{I_{x_1}}{I_0}$

Similarly
$$L_{x_2} = 10 \log \frac{I_{x_2}}{I_0}$$

Thus
$$L_{x_2} - L_{x_1} = 10 \log \frac{I_{x_2}}{I_{x_1}}$$

$$\text{or, } L_{x_2} = L_{x_1} + 10 \log \frac{1/2 \rho a^2 \omega^2 v e^{-2\gamma x_2}}{1/2 \rho a^2 \omega^2 v e^{-2\gamma x_1}} = L_{x_1} + 10 \log e^{-2\gamma(x_2-x_1)}$$

$$L_{x_2} = L_{x_1} - 20\gamma(x_2 - x_1) \log e$$

$$\text{Hence } L' = L - 20\gamma x \log e \quad [\text{since } (x_2 - x_1) = x]$$

$$= 20 \text{ dB} - 20 \times 0.23 \times 50 \times 0.4343 \text{ dB}$$

$$= 60 \text{ dB} - 10 \text{ dB} = 50 \text{ dB}$$

- (b) The point at which the sound is not heard any more, the loudness level should be zero. Thus

$$0 = L - 20\gamma x \log e \quad \text{or } x = \frac{L}{20\gamma \log e} = \frac{60}{20 \times 0.23 \times 0.4343} = 300 \text{ m}$$

- 4.183 (a) As there is no damping, so

$$L_{r_0} = 10 \log \frac{I}{I_0} = 10 \log \frac{1/2 \rho a^2 \omega^2 v / r_0^2}{1/2 \rho a^2 \omega^2 v} = -20 \log r_0$$

$$\text{Similarly } L_r = -20 \log r$$

$$\text{So, } L_r - L_{r_0} = 20 \log (r_0/r)$$

$$\text{or, } L_r = L_{r_0} + 20 \log \left(\frac{r_0}{r} \right) = 30 + 20 \times \log \frac{20}{10} = 36 \text{ dB}$$

- (b) Let r be the sought distance at which the sound is not heard.

$$\text{So, } L_r = L_{r_0} + 20 \log \frac{r_0}{r} = 0 \quad \text{or, } L_{r_0} = 20 \log \frac{r}{r_0} \quad \text{or } 30 = 20 \log \frac{r}{20}$$

$$\text{So, } \log_{10} \frac{r}{20} = 3/2 \quad \text{or } 10^{(3/2)} = r/20$$

$$\text{Thus } r = 200 \sqrt{10} = 0.63 \text{ Km.}$$

Thus for $r > 0.63 \text{ km}$ no sound will be heard.

- 4.184 We treat the fork as a point source. In the absence of damping the oscillation has the form

$$\frac{\text{Const.}}{r} \cos(\omega t - kr)$$

Because of the damping of the fork the amplitude of oscillation decreases exponentially with the retarded time (i.e. the time at which the wave started from the source.). Thus we write for the wave amplitude.

$$\xi = \frac{\text{Const.}}{r} e^{-\beta \left(t - \frac{r}{v} \right)}$$

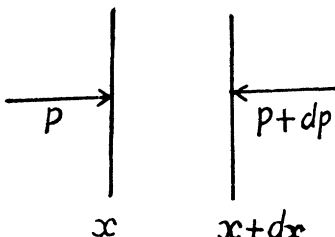
$$\frac{e^{-\beta \left(t + \tau - \frac{r_A}{v} \right)}}{r_A} = \frac{e^{-\beta \left(t + \tau - \frac{r_B}{v} \right)}}{r_B}$$

This means that

Thus
$$e^{-\beta\left(\tau + \frac{r_B - r_A}{v}\right)} = \frac{r_A}{r_B} \quad \text{or} \quad \beta = \frac{\ln \frac{r_B}{r_A}}{\tau + \frac{r_B - r_A}{v}} = 0.12 \text{ s}^{-1}$$

- 4.185 (a) Let us consider the motion of an element of the medium of thickness dx and unit area of cross-section. Let $\xi =$ displacement of the particles of the medium at location x . Then by the equation of motion

$$\rho dx \xi' = -dp$$

where dp is the pressure increment over the length dx

Recalling the wave equation

$$\ddot{\xi} = v^2 \frac{\partial^2 \xi}{\partial x^2}$$

we can write the foregoing equation as

$$\rho v^2 \frac{\partial^2 \xi}{\partial x^2} dx = -dp$$

Integrating this equation, we get

$$\Delta p = \text{surplus pressure} = -\rho v^2 \frac{\partial \xi}{\partial x} + \text{Const.}$$

In the absence of a deformation (a wave), the surplus pressure is $\Delta p = 0$. So 'Const' = 0 and

$$\Delta p = -\rho v^2 \frac{\partial \xi}{\partial x}.$$

- (b) We have found earlier that

$$w = w_k + w_p = \text{total energy density}$$

$$w_k = \frac{1}{2} \rho \left(\frac{\partial \xi}{\partial t} \right)^2, \quad w_p = \frac{1}{2} E \left(\frac{\partial \xi}{\partial x} \right)^2 = \frac{1}{2} \rho v^2 \left(\frac{\partial \xi}{\partial x} \right)^2$$

It is easy to see that the space-time average of both densities is the same and the space time average of total energy density is then

$$\langle w \rangle = \left\langle \rho v^2 \left(\frac{\partial \xi}{\partial x} \right)^2 \right\rangle$$

The intensity of the wave is

$$I = v \langle w \rangle = \left\langle \frac{(\Delta p)^2}{\rho v} \right\rangle$$

Using
$$\left\langle (\Delta p)^2 \right\rangle = \frac{1}{2} (\Delta p)_m^2 \quad \text{we get} \quad I = \frac{(\Delta p)_m^2}{2 \rho v}.$$

4.186 The intensity of the sound wave is

$$I = \frac{(\Delta p)_m^2}{2 \rho v} = \frac{(\Delta p)_m^2}{2 \rho v \lambda}$$

Using $v = \nu \lambda$, ρ is the density of air.

Thus the mean energy flow reaching the ball is

$$\pi R^2 I = \pi R^2 \frac{(\Delta p)_m^2}{2 \rho v \lambda}$$

πR^2 being the effective area (area of cross section) of the ball.

Substitution gives 10.9 mW.

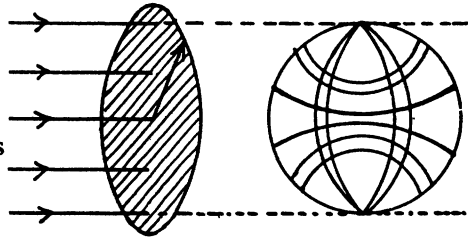

4.187 We have $\frac{P}{4 \pi r^2} = \text{intensity} = \frac{(\Delta p)_m^2}{2 \rho v}$

or
$$(\Delta p)_m = \sqrt{\frac{\rho v P}{2 \pi r^2}}$$

$$= \sqrt{\frac{1.293 \text{ kg/m}^3 \times 340 \text{ m/s} \times 0.80 \text{ W}}{2 \pi \times 1.5 \times 1.5 \text{ m}^2}} = \sqrt{\frac{1.293 \times 340 \times .8}{2 \pi \times 1.5 \times 1.5} \left(\frac{\text{kg kg m}^2 \text{ s}^{-3} \text{ m s}^{-1}}{\text{m}^5} \right)^{\frac{1}{2}}}$$

$$= 4.9877 \left(\text{kg m}^{-1} \text{ s}^{-2} \right) = 5 \text{ Pa} .$$

$$\frac{(\Delta p)_m}{P} = 5 \times 10^{-5}$$

(b) We have

$$\Delta p = -\rho v^2 \frac{\partial \xi}{\partial x}$$

$$(\Delta p)_m = \rho v^2 k \xi_m = \rho v 2 \pi \nu \xi_m$$

$$\xi_m = a = \frac{(\Delta p)_m}{2 \pi \rho v \nu} = \frac{5}{2 \pi \times 1.293 \times 340 \times 600} = 3 \mu \text{ m}$$

$$\frac{\xi_m}{\lambda} = \frac{3 \times 10^{-6}}{340/600} = \frac{1800}{340} \times 10^{-6} = 5 \times 10^{-6}$$

4.188 Express L in bels. (i.e. $L = 5$ bels).

Then the intensity at the relevant point (at a distance r from the source) is : $I_0 \cdot 10^L$

Had there been no damping the intensity would have been : $e^{2\gamma r} I_0 \cdot 10^L$

Now this must equal the quantity

$\frac{P}{4 \pi r^2}$, where P = sonic power of the source.

Thus
$$\frac{P}{4 \pi r^2} = e^{2\gamma r} I_0 \cdot 10^L$$

or
$$P = 4 \pi r^2 e^{2\gamma r} I_0 \cdot 10^L = 1.39 \text{ W} .$$

4.4 ELECTROMAGNETIC WAVES. RADIATION

4.189 The velocity of light in a medium of relative permittivity ϵ is $\frac{c}{\sqrt{\epsilon}}$. Thus the change in wavelength of light (from its value in vacuum to its value in the medium) is

$$\Delta \lambda = \frac{c/\sqrt{\epsilon}}{v} - \frac{c}{v} = \frac{c}{v} \left(\frac{1}{\sqrt{\epsilon}} - 1 \right) = -50 \text{ m.}$$

4.190 From the data of the problem the relative permittivity of the medium varies as

$$\epsilon(x) = \epsilon_1 e^{-(x/l) \ln \frac{\epsilon_1}{\epsilon_2}}$$

Hence the local velocity of light

$$v(x) = \frac{c}{\sqrt{\epsilon(x)}} = \frac{c}{\sqrt{\epsilon_1}} e^{\frac{x}{2l} \ln \frac{\epsilon_1}{\epsilon_2}}$$

Thus the required time $t = \int_0^l \frac{dx}{v(x)} = \frac{\sqrt{\epsilon_1}}{c} \int_0^l e^{-\frac{x}{2l} \ln \frac{\epsilon_1}{\epsilon_2}} dx$

$$dx = \frac{\sqrt{\epsilon_1}}{c} \frac{e^{-\frac{1}{2} \ln \frac{\epsilon_1}{\epsilon_2}} + 1}{\frac{1}{2l} \ln \frac{\epsilon_1}{\epsilon_2}} = \frac{2l}{c} \frac{\sqrt{\epsilon_1} - \sqrt{\epsilon_2}}{\ln \frac{\epsilon_1}{\epsilon_2}}$$

4.191 Conduction current density = $\sigma \vec{E}$

Displacement current density = $\frac{\partial D}{\partial t} = \epsilon \epsilon_0 \frac{\partial E}{\partial t} = i \omega \epsilon \epsilon_0 \vec{E}$

Ratio of magnitudes = $\frac{\sigma}{\omega \epsilon \epsilon_0} = \frac{j_c}{j_{dis}} = 2$, on putting the values.

4.192 $\vec{\nabla} \times \vec{E} = - \frac{\partial \vec{B}}{\partial t} = - \mu_0 \frac{\partial \vec{H}}{\partial t}$

$$= \nabla \cos(\omega t - \vec{k} \cdot \vec{r}) \times \vec{E}_m = \vec{k} \times \vec{E}_m \sin(\omega t - \vec{k} \cdot \vec{r})$$

At

$$\vec{r} = 0$$

$$\frac{\partial \vec{H}}{\partial t} = - \frac{\vec{k} \times \vec{E}_m}{\mu_0} \sin \omega t$$

So integrating (ignoring a constant) and using $c = \frac{1}{\sqrt{\epsilon_0 \mu_0}}$

$$\vec{H} = \frac{\vec{k} \times \vec{E}_m}{\mu_0} \cos c k t \times \frac{1}{c k} = \sqrt{\frac{\epsilon_0}{\mu_0}} \frac{\vec{k} \times \vec{E}_m}{k} \cos c k t$$

4.193 As in the previous problem

$$\begin{aligned}\vec{H} &= \frac{\vec{k} \times \vec{E}_m}{\mu_0 \omega} \cos(\omega t - \vec{k} \cdot \vec{r}) = \frac{E_m}{\mu_0 c} \hat{e}_z \cos(kx - \omega t) \\ &= \sqrt{\frac{\epsilon_0}{\mu_0}} E_m \hat{e}_z \cos(kx - \omega t)\end{aligned}$$

Thus

$$(a) \text{ at } t = 0 \quad \vec{H} = \sqrt{\frac{\epsilon_0}{\mu_0}} E_m \hat{e}_z \cos kx$$

$$(b) \text{ at } t = t_0, \quad \vec{H} = \sqrt{\frac{\epsilon_0}{\mu_0}} E_m \hat{e}_z \cos(kx - \omega t_0)$$

$$\begin{aligned}4.194 \quad \xi_{ind} &= \oint \vec{E} \cdot d\vec{l} = E_m l (\cos \omega t - \cos(\omega t - kl)) \\ &= -2 E_m l \sin \frac{\omega l}{2c} \sin \left(\omega t - \frac{\omega l}{2c} \right)\end{aligned}$$

Putting the values $E_m = 50 \text{ m V/m}$, $l = \frac{1}{2} \text{ metre}$

$$\begin{aligned}\frac{\omega l}{c} &= \frac{2\pi \nu l}{c} = \frac{\pi \times 10^8}{3 \times 10^8} = \frac{\pi}{3} \\ \xi_{ind} &= 50 \text{ m V} \left(-\sin \frac{\pi}{6} \right) \sin \left(\omega t - \frac{\pi}{6} \right) \\ &= -25 \sin \left(\omega t + \frac{\pi}{6} - \frac{\pi}{2} \right) = 25 \cos \left(\omega t - \frac{\pi}{3} \right) \text{ mV}\end{aligned}$$

$$4.195 \quad \vec{E} = \hat{j} E(t, x)$$

$$\vec{B} = \hat{k} B(t, x)$$

$$\text{and} \quad \text{Curl } \vec{E} = \hat{k} \frac{\partial E}{\partial x} = -\frac{\partial \vec{B}}{\partial t} = -\hat{k} \frac{\partial B}{\partial t}$$

$$\text{so} \quad -\frac{\partial E}{\partial x} = \frac{\partial B}{\partial t}$$

$$\text{Also} \quad \text{Curl } \vec{B} = \epsilon_0 \mu_0 \frac{\partial \vec{E}}{\partial t} = \frac{1}{c^2} \frac{\partial \vec{E}}{\partial t}$$

$$\text{and} \quad \text{Curl } \vec{B} = -\hat{j} \frac{\partial B}{\partial x} \quad \text{so} \quad \frac{\partial B}{\partial x} = -\frac{1}{c^2} \frac{\partial E}{\partial t}$$

4.196 $\vec{E} = \vec{E}_m \cos(\omega t - \vec{k} \cdot \vec{r})$ then as before

$$\vec{H} = \sqrt{\frac{\epsilon_0}{\mu_0}} \frac{\vec{k} \times \vec{E}_m}{k} \cos(\omega t - \vec{k} \cdot \vec{r})$$

$$\begin{aligned}
 \text{so } \vec{S} = \vec{E} \times \vec{H} &= \sqrt{\frac{\epsilon_0}{\mu_0}} \vec{E}_m \times (\vec{k} \times \vec{E}_m) \frac{1}{k} \cos^2(\omega t - \vec{k} \cdot \vec{r}) \\
 &= \sqrt{\frac{\epsilon_0}{\mu_0}} \vec{E}_m^2 \frac{\vec{k}}{k} \cos^2(\omega t - \vec{k} \cdot \vec{r}) \\
 \langle \vec{S} \rangle &= \frac{1}{2} \sqrt{\frac{\epsilon_0}{\mu_0}} \vec{E}_m^2 \frac{\vec{k}}{k}
 \end{aligned}$$

$$4.197 \quad E = E_m \cos(2\pi \nu t - kx)$$

$$(a) \quad j_{dis} = \frac{\partial D}{\partial t} = -2\pi \epsilon_0 \nu E_m \sin(\omega t - kx)$$

$$\begin{aligned}
 \text{Thus } (j_{dis})_{rms} &= \langle j_{dis}^2 \rangle^{1/2} \\
 &= \sqrt{2} \pi \epsilon_0 \nu E_m = 0.20 \text{ mA/m}^2.
 \end{aligned}$$

$$(b) \quad \langle S_x \rangle = \frac{1}{2} \sqrt{\frac{\epsilon_0}{\mu_0}} E_m^2 \quad \text{as in (196). Thus } \langle S_x \rangle = 3.3 \mu \text{ W/m}^2$$

4.198 For the Poynting vector we can derive as in (196)

$$\langle S \rangle = \frac{1}{2} \sqrt{\frac{\epsilon \epsilon_0}{\mu_0}} E_m^2 \quad \text{along the direction of propagation.}$$

Hence in time t (which is much longer than the time period T of the wave), the energy reaching the ball is

$$\pi R^2 \times \frac{1}{2} \sqrt{\frac{\epsilon \epsilon_0}{\mu_0}} E_m^2 \times t = 5 \text{ kJ.}$$

4.199 Here $\vec{E} = \vec{E}_m \cos kx \cos \omega t$

From $\text{div } \vec{E} = 0$ we get $E_{mx} = 0$ so \vec{E}_m is in the $y-z$ plane.

Also

$$\begin{aligned}
 \frac{\partial \vec{B}}{\partial t} &= -\vec{\nabla} \times \vec{E} = -\nabla \cos kx \times \vec{E}_m \cos \omega t \\
 &= \vec{k} \times \vec{E}_m \sin kx \cos \omega t
 \end{aligned}$$

$$\text{so } \vec{B} = \frac{\vec{k} \times \vec{E}_m}{\omega} \sin kx \sin \omega t = \vec{B}_m \sin kx \sin \omega t$$

$$\text{Where } \left| \vec{B}_m \right| = \frac{E_m}{c} \quad \text{and } \vec{B}_m \perp \vec{E}_m \text{ in the } y-z \text{ plane.}$$

$$\text{At } t = 0, \quad \vec{B} = 0, \quad E = E_m \cos kx$$

$$\text{At } t = T/4 \quad \vec{E} = 0, \quad B = B_m \sin kx$$

$$4.200 \quad \vec{E} = \vec{E}_m \cos kx \omega t$$

$$\vec{H} = \frac{\vec{k} \times \vec{E}_m}{\mu_0 \omega} \sin kx \sin \omega t \quad (\text{exactly as in 199})$$

$$\vec{S} = \vec{E} \times \vec{H} = \frac{\vec{E}_m \times (\vec{k} \times \vec{E}_m)}{\mu_0 \omega} \frac{1}{4} \sin 2kx \sin 2\omega t$$

Thus

$$S_x = \frac{1}{4} \epsilon_0 c E_m^2 \sin 2kx \sin 2\omega t \quad \left(\text{as } \frac{1}{\mu_0 c} = \epsilon_0 c \right)$$

$$\langle S_x \rangle = 0$$

4.201 Inside the condenser the peak electrical energy $W_e = \frac{1}{2} C V_m^2$

$$= \frac{1}{2} V_m^2 \frac{\epsilon_0 \pi R^2}{d}$$

(d = separation between the plates, πR^2 = area of each plate.)

$V = V_m \sin \omega t$, V_m is the maximum voltage

Changing electric field causes a displacement current

$$j_{dis} = \frac{\partial D}{\partial t} = \epsilon_0 E_m \omega \cos \omega t$$

$$= \frac{\epsilon_0 \omega V_m}{d} \cos \omega t$$

This gives rise to a magnetic field $B(r)$ (at a radial distance r from the centre of the plate)

$$B(r) \cdot 2\pi r = \mu_0 \pi r^2 j_{dis} = \mu_0 \pi r^2 \frac{\epsilon_0 \omega V_m}{d} \cos \omega t$$

$$B = \frac{1}{2} \epsilon_0 \mu_0 \omega \frac{r}{d} V_m \cos \omega t$$

Energy associated with this field is

$$= \int d^3 r \frac{B^2}{2\mu_0} = \frac{1}{8} \epsilon_0^2 \mu_0 \frac{\omega^2}{d^2} 2\pi \int_0^R r^2 r dr \times d \times V_m^2 \cos^2 \omega t$$

$$= \frac{1}{16} \pi \epsilon_0^2 \mu_0 \frac{\omega^2 R^4}{d} V_m^2 \cos^2 \omega t$$

Thus the maximum magnetic energy

$$W_m = \frac{\epsilon_0^2 \mu_0}{16} (\omega R)^2 \frac{\pi R^2}{d} V_m^2$$

Hence

$$\frac{W_m}{W_e} = \frac{1}{8} \epsilon_0 \mu_0 (\omega R)^2 = \frac{1}{8} \left(\frac{\omega R}{c} \right)^2 = 5 \times 10^{-15}$$

The approximation are valid only if $\omega R \ll c$.

4.202 Here $I = I_m \cos \omega t$, then the peak magnetic energy is

$$W_m = \frac{1}{2} L I_m^2 = \frac{1}{2} \mu_0 n^2 I_m^2 \pi R^2 d$$

Changing magnetic field induces an electric field which by Faraday's law is given by

$$E \cdot 2\pi r = -\frac{d}{dt} \int \vec{B} \cdot d\vec{S} = \pi r^2 \mu_0 n I_m \omega \sin \omega t$$

$$E = \frac{1}{2} r \mu_0 n I_m \omega \sin \omega t$$

The associated peak electric energy is

$$W_e = \int \frac{1}{2} \epsilon_0 E^2 d^3 r = \frac{1}{8} \epsilon_0 \mu_0^2 n^2 I_m^2 \omega^2 \sin^2 \omega t \times \frac{\pi R^4}{2}$$

Hence

$$\frac{W_e}{W_m} = \frac{1}{8} \epsilon_0 \mu_0 (\omega R)^2 = \frac{1}{8} \left(\frac{\omega R}{c} \right)^2$$

Again we expect the results to be valid if and only if

$$\left(\frac{\omega R}{c} \right) \ll 1$$

4.203 If the charge on the capacitor is Q , the rate of increase of the capacitor's energy

$$= \frac{d}{dt} \left(\frac{1}{2} \frac{Q^2}{C} \right) = \frac{Q \dot{Q}}{C} = \frac{d}{\epsilon_0 \pi R^2} Q \dot{Q}$$

Now electric field between the plates (inside it) is, $E = \frac{Q}{\pi R^2 \epsilon_0}$.

So displacement current = $\frac{\partial D}{\partial t} = \frac{\dot{Q}}{\pi R^2}$

This will lead to a magnetic field, (circutal) inside the plates. At a radial distance r

$$2\pi r H_\theta(r) = \pi r^2 \frac{\dot{Q}}{\pi R^2} \quad \text{or} \quad H_\theta = \frac{\dot{Q} r}{2\pi R^2}$$

Hence $H_\theta(R) = \frac{Q}{2\pi R}$ at the edge.

Thus inward Poynting vector = $S = \frac{Q}{2\pi R} \times \frac{Q}{\pi R^2 \epsilon_0}$

Total flow = $2\pi R d \times S = \frac{Q \dot{Q} d}{\pi R^2 \epsilon_0}$ Proved

4.204 Suppose the radius of the conductor is R_0 . Then the conduction current density is

$$j_c = \frac{I}{\pi R_0^2} = \sigma E \quad \text{or} \quad E = \frac{I}{\pi R_0^2 \sigma} = \frac{\rho I}{\pi R_0^2}$$

where $\rho = \frac{1}{\sigma}$ is the resistivity.

Inside the conductor there is a magnetic field given by

$$H \cdot 2 \pi R_0 = I \quad \text{or} \quad H = \frac{I}{2 \pi R_0} \quad \text{at the edge}$$

\therefore Energy flowing in per second in a section of length l is

$$E H \times 2 \pi R_0 l = \frac{\rho I^2 l}{\pi R_0^2}$$

$$\text{But the resistance } R = \frac{\rho l}{\pi R_0^2}$$

Thus the energy flowing into the conductor = $I^2 R$.

4.205 Here $n e v = I / \pi R^2$

where R = radius of cross section of the conductor and n = charge density (per unit volume)

$$\text{Also} \quad \frac{1}{2} m v^2 = e U \quad \text{or} \quad v = \sqrt{\frac{2 e U}{m}}$$

Thus, the moving protons have a charge per unit length

$$= n e \pi R^2 = I \sqrt{\frac{m}{2 e U}}$$

This gives rise to an electric field at a distance r given by

$$E = \frac{I}{\epsilon_0} \sqrt{\frac{m}{2 e U}} / 2 \pi r$$

The magnetic field is $H = \frac{I}{2 \pi r}$ (for $r > R$)

Thus

$$S = \frac{I^2}{\epsilon_0 4 \pi^2 r^2} \sqrt{\frac{m}{2 e U}} \quad \text{radially outward from the axis}$$

This is the Poynting vector.

4.206 Within the solenoid $B = \mu_0 n I$ and the rate of change of magnetic energy

$$= \dot{W}_m = \frac{d}{dt} \left(\frac{1}{2} \mu_0 n^2 I^2 \pi R^2 l \right) = \mu_0 n^2 \pi R^2 l I \dot{I}$$

where R = radius of cross section of the solenoid l = length.

Also $H = B / \mu_0 = n I$ along the axis within the solenoid.

By Faraday's law, the induced electric field is

$$E_\theta 2 \pi r = \pi r^2 \dot{B} = \pi r^2 \mu_0 n \dot{I}$$

or

$$E_\theta = \frac{1}{2} \mu_0 n \dot{I} r$$

so at the edge $E_{\theta}(R) = \frac{1}{2} \mu_0 n \dot{I} R$ (circuital)

Then $S_r = E_{\theta} H_z$ (radially inward)

and $\dot{W}_m = \frac{1}{2} \mu_0 n^2 \dot{I} \dot{I} R \times 2 \pi R l = \mu_0 n^2 \pi R^2 l \dot{I} \dot{I}$ as before.

4.207 Given $\varphi_2 > \varphi_1$

The electric field is as shown by the dashed lines (----→----).

The magnetic field is as shown (\odot) emerging out of the paper.

$\vec{S} = \vec{E} \times \vec{H}$ is parallel to the wires and towards right.

Hence source must be on the left.

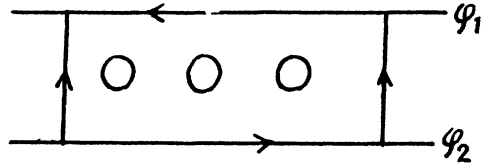

4.208 The electric field (----→) and the magnetic field ($H \rightarrow$) are as shown.

The electric field by Gauss's theorem is like

$$E_r = \frac{A}{r}$$

Integrating

$$\varphi = A \ln \frac{r_2}{r}$$

so

$$A = \frac{V}{\ln \frac{r_2}{r_1}} \quad (r_2 > r_1)$$

Then

$$E = \frac{V}{r \ln \frac{r_2}{r_1}}$$

Magnetic field is

$$H_{\theta} = \frac{I}{2 \pi r}$$

The Poynting vector S is along the Z axis and non zero between the two wires ($r_1 < r < r_2$). The total power flux is

$$= \int_{r_1}^{r_2} \frac{IV}{2 \pi r^2 \ln \frac{r_2}{r_1}} \cdot 2 \pi r dr = IV$$

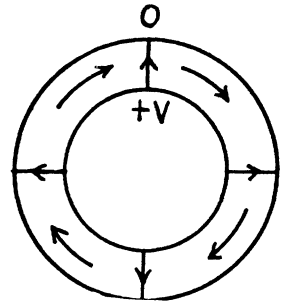

4.209 As in the previous problem

$$E_r = \frac{V_0 \cos \omega t}{r \ln \frac{r_2}{r_1}} \quad \text{and} \quad H_{\theta} = \frac{I_0 \cos(\omega t - \varphi)}{2 \pi r}$$

Hence time averaged power flux (along the z axis) = $\frac{1}{2} V_0 I_0 \cos \varphi$

On using $\langle \cos \omega t \cos (\omega t - \varphi) \rangle = \frac{1}{2} \cos \varphi$.

4.210 Let \vec{n} be along the z axis. Then

$$S_{1n} = E_{1x} H_{1y} - E_{1y} H_{1x}$$

and

$$S_{2n} = E_{2x} H_{2y} - E_{2y} H_{2x}$$

Using the boundary condition $E_{1t} = E_{2t}$, $H_{1t} = H_{2t}$ at the boundary ($t = x$ or y) we see that

$$S_{1n} = S_{2n}.$$

4.211 $P \cdot \alpha |\dot{\vec{p}}|^2$ when

$$\vec{p} = \sum e_i \vec{r}_i = \sum \frac{e_i}{m_i} m_i \vec{r}_i = \frac{e}{m} \sum m_i \vec{r}_i$$

if $\frac{e_i}{m_i} = \frac{e}{m} = \text{fixed}$

But $\frac{d^2}{dt^2} \sum m_i \vec{r}_i = 0$ for a closed system

Hence $P = 0$.

$$4.212 P = \frac{1}{4\pi\epsilon_0} \frac{2(\dot{\vec{p}})^2}{3c^3}$$

Thus $\langle P \rangle = \frac{1}{4\pi\epsilon_0} \frac{2}{3c^3} (e\omega^2 a)^2 \times \frac{1}{2} = \frac{e^2 \omega^4 a^2}{12\pi\epsilon_0 c^3} = 5.1 \times 10^{-15} \text{ W}$.

4.213 Here

$$\dot{\vec{p}} = \frac{e}{m} \times \text{force} = \frac{e^2 q}{m R^2} \frac{1}{4\pi\epsilon_0}.$$

Thus $P = \frac{1}{(4\pi\epsilon_0)^3} \left(\frac{e^2 q}{m R^2} \right)^2 \frac{2}{3c^3}$.

4.214 Most of the radiation occurs when the moving particle is closest to the stationary particle. In that region, we can write

$$R^2 = b^2 + v^2 t^2$$

and apply the previous problem's formula

Thus $\Delta W = \frac{1}{(4\pi\epsilon_0)^3} \frac{2}{3c^3} \int_{-\infty}^{\infty} \left(\frac{qe^2}{m} \right)^2 \frac{dt}{(b^2 + v^2 t^2)^2}$

(the integral can be taken between $\pm \infty$ with little error.)

Now
$$\int_{-\infty}^{\infty} \frac{dt}{(b^2 + v^2 t^2)^2} = \frac{1}{v} \int_{-\infty}^{\infty} \frac{dx}{(b^2 + x^2)^2} = \frac{\pi}{2 v b^3}.$$

Hence,
$$\Delta W = \frac{1}{(4 \pi \epsilon_0)^3} \frac{\pi q^2 e^4}{3 c^3 m^2 v b^3}.$$

4.215 For the semicircular path on the right

$$\frac{m v^2}{R} = B e v \quad \text{or} \quad v = \frac{B e R}{m}.$$

Thus K.E. = $T = \frac{1}{2} m v^2 = \frac{B^2 e^2 R^2}{2 m}.$

Power radiated = $\frac{1}{4 \pi \epsilon_0} \frac{2}{3 c^3} \left(\frac{e v^2}{R} \right)^2$

Hence energy radiated = ΔW

$$= \frac{1}{4 \pi \epsilon_0} \frac{2}{3 c^3} \left(\frac{B^2 e^3 R}{m^2} \right)^2 \cdot \frac{\pi R}{B e R} m = \frac{B^3 e^5 R^2}{6 \epsilon_0 m^3 c^3}$$

So
$$\frac{\Delta W}{T} = \frac{B e^3}{3 \epsilon_0 c^3 m^2} = 2.06 \times 10^{-18}.$$

(neglecting the change in v due to radiation, correct if $\Delta W/T \ll 1$).

4.216 $R = \frac{m v}{e B}.$

Then
$$P = \frac{1}{4 \pi \epsilon_0} \frac{2}{3 c^3} \left(\frac{e v^2}{R} \right)^2 = \frac{1}{4 \pi \epsilon_0} \frac{2}{3 c^3} \left(\frac{e^2 B v}{m} \right)^2$$

$$= \frac{1}{3 \pi \epsilon_0 c^3} \left(\frac{B^2 e^4}{m^3} \right) T$$

This is the radiated power so

$$\frac{dT}{dt} = - \frac{B^2 e^4}{3 \pi \epsilon_0 m^3 c^3} T$$

Integrating, $T = T_0 e^{-t/\tau}$

$$\tau = \frac{3 \pi \epsilon_0 m^3 c^3}{B^2 e^4}$$

τ is $(1836)^3 \approx 10^{10}$ times less for an electron than for a proton so electrons radiate away their energy much faster in a magnetic field.

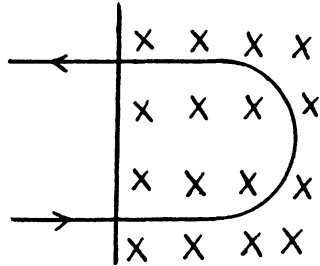

4.217 P is a fixed point at a distance l from the equilibrium position of the particle. Because $l \gg a$, to first order in $\frac{a}{l}$ the distance between P and the instantaneous position of the particle is still l . For the first case $y = 0$ so $t = T/4$

The corresponding retarded time is $t' = \frac{T}{4} - \frac{l}{c}$

$$\text{Now} \quad \ddot{y}(t') = -\omega^2 a \cos \omega \left(\frac{T}{4} - \frac{l}{c} \right) = -\omega^2 a \sin \frac{\omega l}{c}$$

For the second case $y = a$ at $t = 0$ so at the retarded time $t' = -\frac{\omega l}{c}$

$$\text{Thus} \quad \ddot{y}(t') = -\omega^2 a \cos \frac{\omega l}{c}$$

The radiation fluxes in the two cases are proportional to $(\ddot{y}(t'))^2$ so

$$\frac{S_1}{S_2} = \tan^2 \frac{\omega l}{c} = 3.06 \text{ on substitution.}$$

Note : The radiation received at P at time t depends on the acceleration of the charge at the retarded time.

4.218 Along the circle $x = R \sin \omega t$, $y = R \cos \omega t$

where $\omega = \frac{v}{R}$. If t is the parameter in $x(t), y(t)$ and t' is the observer time then

$$t' = t + \frac{l - x(t)}{c}$$

where we have neglected the effect of the y -coordinate which is of second order. The observed coordinate are

$$x'(t') = x(t), \quad y'(t') = y(t)$$

$$\text{Then} \quad \frac{dy'}{dt'} = \frac{dy}{dt'} = \frac{dt}{dt'} \frac{dy}{dt} = \frac{-\omega R \sin \omega t}{1 - \frac{\omega R}{c} \cos \omega t} = \frac{-\omega x}{1 - \frac{\omega y}{c}} = \frac{-v x/R}{1 - \frac{v y}{c R}}$$

$$\text{and} \quad \frac{d^2 y'}{dt'^2} = \frac{dt}{dt'} \frac{d}{dt} \left(\frac{-v x/R}{1 - \frac{v y}{c R}} \right)$$

$$= \frac{1}{1 - \frac{v y}{c R}} \left\{ \frac{-\frac{v^2}{R^2} y}{1 - \frac{v y}{c R}} + \frac{\frac{v x}{R} \left(\frac{v^2}{c R^2} x \right)}{\left(1 - \frac{v y}{c R} \right)^2} \right\} = \frac{\frac{v^2}{R} \left(\frac{v}{c} - \frac{y}{R} \right)}{\left(1 - \frac{v y}{c R} \right)^3}$$

This is the observed acceleration.

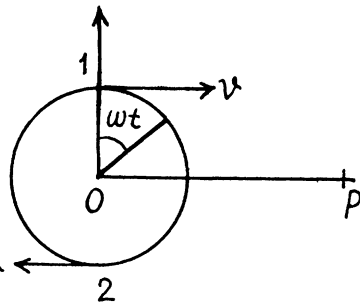

(b) Energy flow density of EM radiation S is proportional to the square of the y - projection of the observed acceleration of the particle (i.e. $\frac{d^2 y'}{dt'^2}$).

Thus

$$\frac{S_1}{S_2} = \left[\frac{\left(\frac{v}{c} - 1\right)}{\left(1 - \frac{v}{c}\right)^3} / \frac{\left(\frac{v}{c} + 1\right)}{\left(1 + \frac{v}{c}\right)^3} \right]^2 = \frac{\left(1 + \frac{v}{c}\right)^4}{\left(1 - \frac{v}{c}\right)^4}.$$

4.219 We know that $S_0(r) \propto \frac{1}{r^2}$

At other angles $S(r, \theta) \propto \sin^2 \theta$

Thus $S(r, \theta) = S_0(r) \sin^2 \theta = S_0 \sin^2 \theta$

Average power radiated

$$= S_0 \times 4\pi r^2 \times \frac{2}{3} = \frac{8\pi}{3} S_0 r^2$$

(Average of $\sin^2 \theta$ over whole sphere is $\frac{2}{3}$)

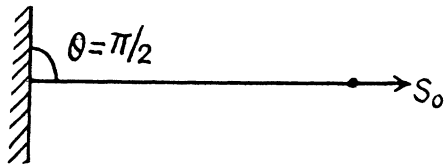

4.220 From the previous problem.

$$P_0 = \frac{8\pi S_0 r^2}{3}$$

or

$$S_0 = \frac{3P_0}{8\pi r^2}$$

Thus

$$\langle w \rangle = \frac{S_0}{c} = \frac{3P_0}{8\pi c r^2}$$

(Poynting flux vector is the energy contained in a box of unit cross section and length c).

4.221 The rotating dipole has moments

$$p_x = p \cos \omega t, \quad p_y = p \sin \omega t$$

Thus

$$P = \frac{1}{4\pi \epsilon_0} \frac{2}{3c^3} \omega^4 p^2 = \frac{p^2 \omega^4}{6\pi \epsilon_0 c^3}.$$

4.222 If the electric field of the wave is

$$\vec{E} = \vec{E}_0 \cos \omega t$$

then this induces a dipole moment whose second derivative is

$$\ddot{p} = \frac{e^2 \vec{E}_0}{m} \cos \omega t$$

Hence radiated mean power $\langle P \rangle = \frac{1}{4\pi \epsilon_0} \frac{2}{3c^3} \left(\frac{e^2 E_0}{m} \right)^2 \times \frac{1}{2}$

On the other hand the mean Poynting flux of the incident radiation is

$$\langle S_{inc} \rangle = \sqrt{\frac{\epsilon_0}{\mu_0}} \times \frac{1}{2} E_0^2$$

Thus

$$\begin{aligned} \frac{P}{\langle S_{inc} \rangle} &= \frac{1}{4\pi\epsilon_0} \cdot \frac{2}{3} (\epsilon_0\mu_0)^{3/2} \left(\frac{e^2}{m}\right)^2 \times \sqrt{\frac{\mu_0}{\epsilon_0}} \\ &= \frac{\mu_0^2}{6\pi} \left(\frac{e^2}{m}\right)^2 \end{aligned}$$

4.223 For the elastically bound electron

$$m \ddot{\vec{r}} + m \omega_0^2 \vec{r} = e \vec{E}_0 \cos \omega t$$

This equation has the particular integral

(i.e. neglecting the part which does not have the frequency of the impressed force)

$$\vec{r} = \frac{e \vec{E}_0}{m} \frac{\cos \omega t}{\omega_0^2 - \omega^2} \quad \text{so and} \quad \ddot{\vec{p}} = - \frac{e^2 \vec{E}_0 \omega^2}{(\omega_0^2 - \omega^2) m} \cos \omega t$$

Hence P = mean radiated power

$$= \frac{1}{4\pi\epsilon_0} \frac{2}{3c^3} \left(\frac{e^2 \omega^2}{m(\omega_0^2 - \omega^2)} \right)^2 \frac{1}{2} E_0^2$$

The mean incident poynting flux is

$$\langle S_{inc} \rangle = \sqrt{\frac{\epsilon_0}{\mu_0}} \frac{1}{2} E_0^2$$

Thus

$$\frac{P}{\langle S_{inc} \rangle} = \frac{\mu_0^2}{6\pi} \left(\frac{e^2}{m}\right)^2 \frac{\omega^4}{(\omega_0^2 - \omega^2)^2}$$

4.224 Let r = radius of the ball

R = distance between the ball & the Sun ($r \ll R$).

M = mass of the Sun

γ = gravitational constant

Then

$$\frac{\gamma M}{R^2} \frac{4\pi}{3} r^3 \rho = \frac{P}{4\pi R^2} \pi r^2 \cdot \frac{1}{c}$$

(the factor $\frac{1}{c}$ converts the energy received on the right into momentum received. Then the right hand side is the momentum received per unit time and must equal the negative of the impressed force for equilibrium).

Thus

$$r = \frac{3P}{16\pi\gamma M c \rho} = 0.606 \mu \text{ m.}$$



PART FIVE

OPTICS

5.1 PHOTOMETRY AND GEOMETRICAL OPTICS

5.1 (a) The relative spectral response $V(\lambda)$ shown in Fig. (5.11) of the book is so defined that $A/V(\lambda)$ is the energy flux of light of wave length λ needed to produce a unit luminous flux at that wavelength. (A is the conversion factor defined in the book.)

At $\lambda = 0.51 \mu\text{m}$, we read from the figure

$$V(\lambda) = 0.50 \text{ so}$$

energy flux corresponding to a luminous flux of 1 lumen = $\frac{1.6}{0.50} = 3.2 \text{ mW}$

At $\lambda = 0.64 \mu\text{m}$, we read

$$V(\lambda) = 0.17$$

and energy flux corresponding to a luminous flux of 1 lumen = $\frac{1.6}{.17} = 9.4 \text{ mW}$

(b) Here $d\Phi_e(\lambda) = \frac{\Phi_e}{\lambda_2 - \lambda_1} d\lambda$, $\lambda_1 \leq \lambda \leq \lambda_2$

since energy is distributed uniformly. Then

$$\Phi = \int_{\lambda_1}^{\lambda_2} V(\lambda) d\Phi_e(\lambda)/A = \frac{\Phi_e}{A(\lambda_2 - \lambda_1)} \int_{\lambda_1}^{\lambda_2} V(\lambda) d\lambda$$

since $V(\lambda)$ is assumed to vary linearly in the interval $\lambda_1 \leq \lambda \leq \lambda_2$, we have

$$\frac{1}{\lambda_2 - \lambda_1} \int_{\lambda_1}^{\lambda_2} V(\lambda) d\lambda = \frac{1}{2} (V(\lambda_1) + V(\lambda_2))$$

Thus
$$\Phi = \frac{\Phi_e}{2A} (V(\lambda_1) + V(\lambda_2))$$

Using
$$V(0.58 \mu\text{m}) = 0.85$$

$$V(0.63 \mu\text{m}) = 0.25$$

Thus
$$\Phi = \frac{\Phi_e}{2 \times 1.6} \times 1.1 = 1.55 \text{ lumen.}$$

5.2 We have $\Phi_e = \frac{\Phi A}{V(\lambda)}$

But
$$\Phi_e = \frac{1}{2} \sqrt{\frac{\epsilon_0}{\mu_0}} E_m^2 \times \frac{4\pi r^2}{\text{area}} \quad \text{or} \quad E_m^2 = \frac{\Phi A}{2\pi r^2 V(\lambda)} \sqrt{\frac{\mu_0}{\epsilon_0}}$$

↓
mean energy
flux vector

For $\lambda = 0.59 \mu\text{m}$ $V(\lambda) = 0.74$ Thus
 $E_m = 1.14 \text{ V/m}$

Also $H_m = \sqrt{\frac{\epsilon_0}{\mu_0}} E_m = 3.02 \text{ mA/m}$

5.3 (a) Mean illuminance

$$= \frac{\text{Total luminous flux incident}}{\text{Total area illuminated}}$$

Now, to calculate the total luminous flux incident on the sphere, we note that the illuminance at the point of normal incidence is E_0 . Thus the incident flux is $E_0 \cdot \pi R^2$. Thus

$$\text{Mean illuminance} = \frac{\pi R^2 \cdot E_0}{2\pi R^2}$$

or $\langle E \rangle = \frac{1}{2} E_0$.

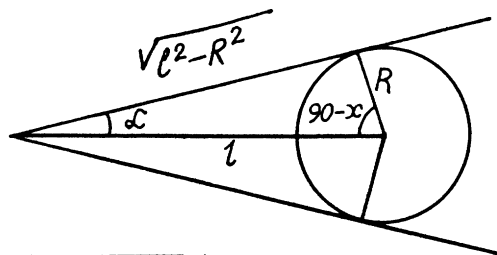

(b) The sphere subtends a solid angle

$$2\pi(1 - \cos \alpha) = 2\pi \left(1 - \frac{\sqrt{l^2 - R^2}}{l}\right)$$

at the point source and therefore receives a total flux of

$$2\pi I \left(1 - \frac{\sqrt{l^2 - R^2}}{l}\right)$$

$90 - \alpha$

The area irradiated is : $2\pi R^2 \int_0^{90-\alpha} \sin \theta d\theta = 2\pi R^2(1 - \sin \alpha) = 2\pi R^2 \left(1 - \frac{R}{l}\right)$

Thus
$$\langle E \rangle = \frac{I}{R^2} \frac{1 - \sqrt{1 - (R/l)^2}}{1 - \frac{R}{l}}$$

Substituting we get $\langle E \rangle = 50 \text{ lux}$.

- 5.4 Luminance L is the light energy emitted per unit area of the emitting surface in a given direction per unit solid angle divided by $\cos \theta$. Luminosity M is simply energy emitted per unit area.

Thus

$$M = \int L \cdot \cos \theta \cdot d\Omega$$

where the integration must be in the forward hemisphere of the emitting surface (assuming light is being emitted in only one direction say outward direction of the surface.) But

$$L = L_0 \cos \theta$$

$$\text{Thus } M = \int L_0 \cos^2 \theta \cdot d\Omega = 2\pi \int_0^{\pi/2} L_0 \cos^2 \theta \sin \theta d\theta = \frac{2}{3} \pi L_0$$

- 5.5 (a) For a Lambert source $L = \text{Const}$

The flux emitted into the cone is

$$\Phi = L \Delta S \cos \alpha d\Omega$$

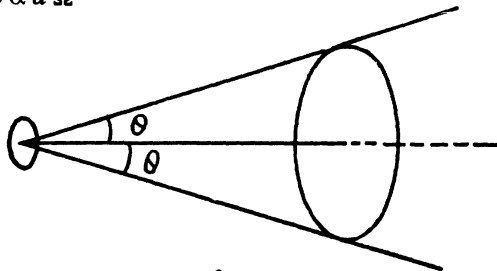

$$\begin{aligned} &= L \Delta S \int_0^{\theta} 2\pi \cos \alpha \sin \alpha d\alpha \\ &= L \Delta S \pi (1 - \cos^2 \theta) = \pi L \Delta S \sin^2 \theta \end{aligned}$$

- (b) The luminosity is obtained from the previous formula for $\theta = 90^\circ$

$$M = \frac{\Phi(\theta = 90^\circ)}{\Delta S} = \pi L$$

- 5.6 The equivalent luminous intensity in the direction OP is

$$L S \cos \theta$$

and the illuminance at P is

$$\begin{aligned} \frac{L S \cos \theta}{(R^2 + h^2)} \cos \theta &= \frac{L S h^2}{(R^2 + h^2)^2} \\ &= \frac{L S}{\left(\frac{R^2}{h} + h\right)^2} = \frac{L S}{\left[\left(\frac{R}{\sqrt{h}} - \sqrt{h}\right)^2 + 2R\right]^2} \end{aligned}$$

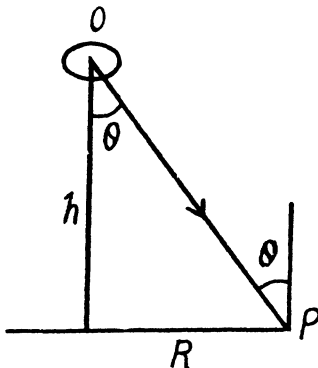

This is maximum when $R = h$
and the maximum illuminance is

$$\frac{LS}{4R^2} = \frac{1.6 \times 10^2}{4} = 40 \text{ lux}$$

5.7 The illuminance at P is

$$E_P = \frac{I(\theta)}{(x^2 + h^2)} \cos \theta = \frac{I(\theta) \cos^3 \theta}{h^2}$$

since this is constant at all x , we must have

$$I(\theta) \cos^3 \theta = \text{const} = I_0$$

$$\text{or } I(\theta) = I_0 / \cos^3 \theta$$

The luminous flux reaching the table is

$$\Phi = \pi R^2 \times \frac{I_0}{h^2} = 314 \text{ lumen}$$

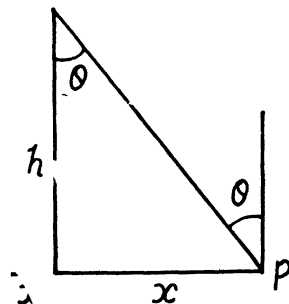

5.8 The illuminated area acts as a Lambert source of luminosity $M = \pi L$ where

$$MS = \rho ES = \text{total reflected light}$$

Thus, the luminance

$$L = \frac{\rho E}{\pi}$$

The equivalent luminous intensity in the direction making an angle θ from the vertical is

$$LS \cos \theta = \frac{\rho ES}{\pi} \cos \theta$$

and the illuminance at the point P is

$$\frac{\rho ES}{\pi} \cos \theta \sin \theta / R^2 \operatorname{cosec}^2 \theta = \frac{\rho ES}{\pi R^2} \cos \theta \sin^3 \theta$$

This is maximum when

$$\frac{d}{d\theta} (\cos \theta \sin^3 \theta) = -\sin^4 \theta + 3 \sin^2 \theta \cos^2 \theta = 0$$

$$\text{or } \tan^2 \theta = 3 \Rightarrow \tan \theta = \sqrt{3}$$

Then the maximum illuminance is

$$\frac{3\sqrt{3}}{16\pi} \frac{\rho ES}{R^2}$$

This illuminance is obtained at a distance $R \cot \theta = R/\sqrt{3}$ from the ceiling. Substitution gives the value

$$0.21 \text{ lux}$$

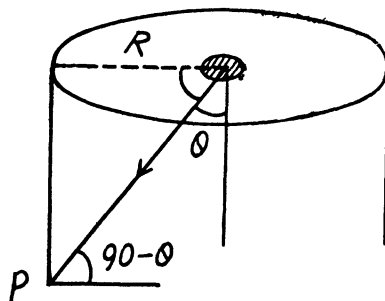

- 5.9 From the definition of luminance, the energy emitted in the radial direction by an element dS of the surface of the dome is

$$d\Phi = L dS d\Omega$$

Here $L = \text{constant}$. The solid angle $d\Omega$ is given by

$$d\Omega = \frac{dA \cos \theta}{R^2}$$

where dA is the area of an element on the plane illuminated by the radial light. Then

$$d\Phi = \frac{L dS dA}{R^2} \cos \theta$$

The illuminance at O is then

$$E = \int \frac{d\Phi}{dA} = \int_0^{\pi/2} \frac{L}{R^2} 2\pi R^2 \sin \theta d\theta \cos \theta = 2\pi L \int_0^1 x dx = \pi L$$

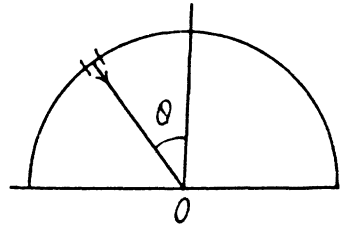

- 5.10 Consider an element of area dS at point P . It emits light of flux

$$\begin{aligned} d\Phi &= L dS d\Omega \cos \theta \\ &= L dS \frac{dA}{h^2 \sec^2 \theta} \cdot \cos^2 \theta \\ &= \frac{L dS dA}{h^2} \cos^4 \theta \end{aligned}$$

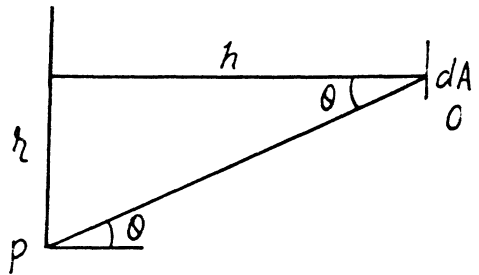

in the direction of the surface element dA at O .

The total illuminance at O is then

$$E = \int \frac{L dS}{h^2} \cos^4 \theta$$

But

$$\begin{aligned} dS &= 2\pi r dr = 2\pi h \tan \theta d(h \tan \theta) \\ &= 2\pi h^2 \sec^2 \theta \tan \theta d\theta \end{aligned}$$

Substitution gives

$$E = 2\pi L \int_0^{\pi/2} \sin \theta \cos \theta d\theta = \pi L$$

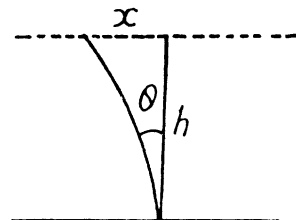

- 5.11 Consider an angular element of area

$$2\pi x dx = 2\pi h^2 \tan \theta \sec^2 \theta d\theta$$

Light emitted from this ring is

$$d\Phi = L d\Omega (2\pi h^2 \tan \theta \sec^2 \theta d\theta) \cdot \cos \theta$$

Now
$$d\Omega = \frac{dA \cos \theta}{h^2 \sec^2 \theta}$$

where dA = an element of area of the table just below the centre of the illuminant.

Then the illuminance at the element dA will be

$$E_0 = \int_{\theta=0}^{\theta=\alpha} 2\pi L \sin \theta \cos \theta d\theta$$

where
$$\sin \alpha = \frac{R}{\sqrt{h^2 + R^2}}$$
. Finally using luminosity $M = \pi L$

$$E_0 = M \sin^2 \alpha = M \frac{R^2}{h^2 + R^2}$$

or
$$M = E_0 \left(1 + \frac{h^2}{R^2} \right) = 700 \text{ lm/m}^2 \cdot \left(1 \text{ lx} = 1 \frac{\text{lm}}{\text{m}^2} \text{ dimensionally} \right).$$

5.12 See the figure below. The light emitted by an element of the illuminant towards the point O under consideration is

$$d\Phi = L dS d\Omega \cos(\alpha + \beta)$$

The element dS has the area

$$dS = 2\pi R^2 \sin \alpha d\alpha$$

The distance

$$OA = [h^2 + R^2 - 2hR \cos \alpha]^{1/2}$$

we also have

$$\frac{OA}{\sin \alpha} = \frac{h}{\sin(\alpha + \beta)} = \frac{R}{\sin \beta}$$

From the diagram

$$\cos(\alpha + \beta) = \frac{h \cos \alpha - R}{OA}$$

$$\cos \beta = \frac{h - R \cos \alpha}{OA}$$

If we imagine a small area $d\Sigma$ at O then

$$\frac{d\Sigma \cos \beta}{OA^2} = d\Omega$$

Hence, the illuminance at O is

$$\int \frac{d\Phi}{d\Sigma} = \int L 2\pi R^2 \sin \alpha d\alpha \frac{(h \cos \alpha - R)(h - R \cos \alpha)}{(OA)^4}$$

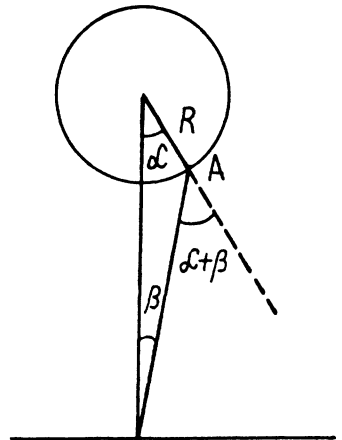

The limit of α is $\alpha = 0$ to that value for which $\alpha + \beta = 90^\circ$, for then light is emitted tangentially. Thus

$$\alpha_{\max} = \cos^{-1} \frac{R}{h}.$$

Thus

$$E = \int_0^{\cos^{-1} \frac{R}{h}} L \cdot 2 \pi R^2 \sin \alpha \, d\alpha \frac{(h - R \cos \alpha)(h \cos \alpha - R)}{(h^2 + R^2 - 2hR \cos \alpha)^2}$$

we put

$$y = h^2 + R^2 - 2hR \cos \alpha$$

So,

$$dy = 2hR \sin \alpha \, d\alpha$$

$$\begin{aligned} E &= \int_{(h-R)^2}^{h^2-R^2} L \cdot 2 \pi R^2 \frac{dy}{2hR} \frac{\left(h - \frac{h^2 + R^2 - y}{2h}\right) \left(\frac{h^2 + R^2 - y}{2R} - R\right)}{y^2} \\ &= \frac{L \cdot 2 \pi R^2}{8h^2 R^2} \int_{(h-R)^2}^{h^2-R^2} \frac{(h^2 - R^2 + y)(h^2 - R^2 - y)}{y^2} dy \\ &= \frac{\pi L}{4h^2} \int_{(h-R)^2}^{h^2-R^2} \left[\frac{(h^2 - R^2)^2}{y^2} - 1 \right] dy = \frac{\pi L}{4h^2} \left[-\frac{(h^2 - R^2)^2}{y} - y \right]_{(h-R)^2}^{h^2-R^2} \\ &= \frac{\pi L}{4h^2} \left[(h+R)^2 - (h^2 - R^2) - (h^2 - R^2) + (h-R)^2 \right] \\ &= \frac{\pi L}{4h^2} \left[2h^2 + 2R^2 - 2h^2 + 2R^2 \right] = \frac{\pi L R^2}{h^2} \end{aligned}$$

Substitution gives :

$$E = 25 \cdot 1 \text{ lux}$$

5.13 We see from the diagram that because of the law of reflection, the component of the incident unit vector \vec{e} along \vec{n} changes sign on reflection while the component \parallel to the mirror remains unchanged.

Writing $\vec{e} = \vec{e}_{\parallel} + \vec{e}_{\perp}$

where $\vec{e}_{\perp} = \vec{n}(\vec{e} \cdot \vec{n})$

$$\vec{e}_{\parallel} = \vec{e} - \vec{n}(\vec{e} \cdot \vec{n})$$

we see that the reflected unit vector is

$$\vec{e}' = \vec{e}_{\parallel} - \vec{e}_{\perp} = \vec{e} - 2\vec{n}(\vec{e} \cdot \vec{n})$$

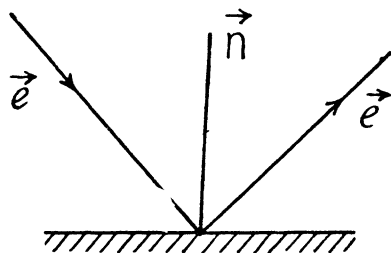

5.14 We choose the unit vectors perpendicular to the mirror as the x, y, z axes in space. Then after reflection from the mirror with normal along x axis

$$\vec{e}' = \vec{e} - 2 \hat{i} (\hat{i} \cdot \vec{e}) = -e_x \hat{i} + e_y \hat{j} + e_z \hat{k}$$

where $\hat{i}, \hat{j}, \hat{k}$ are the basic unit vectors. After a second reflection from the 2nd mirror say along y axis.

$$\vec{e}'' = \vec{e}' - 2 \hat{j} (\hat{j} \cdot \vec{e}') = -e_x \hat{i} - e_y \hat{j} + e_z \hat{k}$$

Finally after the third reflection

$$\vec{e}''' = -e_x \hat{i} - e_y \hat{j} - e_z \hat{k} = -\vec{e}$$

5.15 Let PQ be the surface of water and n be the R.I. of water. Let AO is the shaft of light with incident angle θ_1 and OB and OC are the reflected and refracted light rays at angles

θ_1 and θ_2 respectively (Fig.). From the figure $\theta_2 = \frac{\pi}{2} - \theta_1$

From the law of refraction at the interface PQ

$$n = \frac{\sin \theta_1}{\sin \theta_2} = \frac{\sin \theta_1}{\sin \left(\frac{\pi}{2} - \theta_1 \right)}$$

$$\text{or, } n = \frac{\sin \theta_1}{\cos \theta_1} = \tan \theta_1$$

Hence $\theta_1 = \tan^{-1} n$

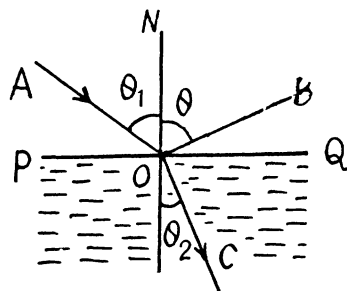

5.16 Let two optical mediums of R.I. n_1 and n_2 respectively be such that $n_1 > n_2$. In the case when angle of incidence is θ_{1cr} (Fig.), from the law of refraction

$$n_1 \sin \theta_{1cr} = n_2 \quad (1)$$

In the case, when the angle of incidence is θ_1 , from the law of refraction at the interface of mediums 1 and 2.

$$n_1 \sin \theta_1 = n_2 \sin \theta_2$$

But in accordance with the problem $\theta_2 = (\pi/2 - \theta_1)$

so,

$$n_1 \sin \theta_1 = n_2 \cos \theta_1 \quad (2)$$

Dividing Eqn (1) by (2)

$$\frac{\sin \theta_{1cr}}{\sin \theta_1} = \frac{1}{\cos \theta_1}$$

$$\text{or, } \eta = \frac{1}{\cos \theta_1}, \text{ so } \cos \theta_1 = \frac{1}{\eta} \text{ and } \sin \theta_1 = \frac{\sqrt{\eta^2 - 1}}{\eta} \quad (3)$$

$$\text{But } \frac{n_1}{n_2} = \frac{\cos \theta_1}{\sin \theta_1}$$

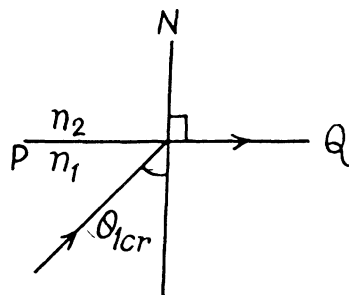

So,
$$\frac{n_1}{n_2} = \frac{1}{\eta} \frac{\eta}{\sqrt{\eta^2 - 1}} \quad (\text{Using 3})$$

Thus
$$\frac{n_1}{n_2} = \frac{1}{\sqrt{\eta^2 - 1}}$$

5.17 From the Fig. the sought lateral shift

$$\begin{aligned} x &= OM \sin(\theta - \beta) \\ &= d \sec \beta \sin(\theta - \beta) \\ &= d \sec \beta (\sin \theta \cos \beta - \cos \theta \sin \beta) \\ &= d (\sin \theta - \cos \theta \tan \beta) \end{aligned}$$

But from the law of refraction

$$\sin \theta = n \sin \beta \quad \text{or,} \quad \sin \beta = \frac{\sin \theta}{n}$$

So,
$$\cos \beta = \frac{\sqrt{n^2 - \sin^2 \theta}}{n} \quad \text{and} \quad \tan \beta = \frac{\sin \theta}{\sqrt{n^2 - \sin^2 \theta}}$$

Thus
$$\begin{aligned} x &= d (\sin \theta - \cos \theta \tan \beta) = d \left(\sin \theta - \cos \theta \frac{\sin \theta}{\sqrt{n^2 - \sin^2 \theta}} \right) \\ &= d \sin \theta \left[1 - \sqrt{\frac{1 - \sin^2 \theta}{n^2 - \sin^2 \theta}} \right] \end{aligned}$$

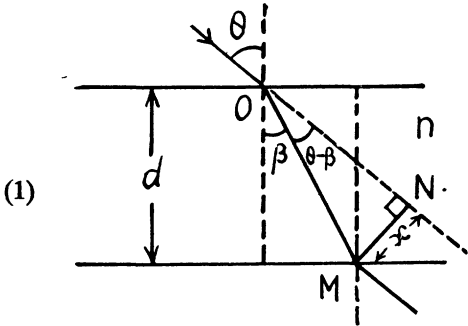

5.18 From the Fig.

$$\sin d\alpha = \frac{MP}{OM} = \frac{MN \cos \alpha}{h \sec(\alpha + d\alpha)}$$

As $d\alpha$ is very small, so

$$d\alpha \approx \frac{MN \cos \alpha}{h \sec \alpha} = \frac{MN \cos^2 \alpha}{h} \quad (1)$$

Similarly

$$d\theta = \frac{MN \cos^2 \theta}{h'} \quad (2)$$

From Eqns (1) and (2)

$$\frac{d\alpha}{d\theta} = \frac{h' \cos^2 \alpha}{h \cos^2 \theta} \quad \text{or,} \quad h' = \frac{h \cos^2 \theta}{\cos^2 \alpha} \frac{d\alpha}{d\theta} \quad (3)$$

From the law of refraction

$$n \sin \alpha = \sin \theta \quad (A)$$

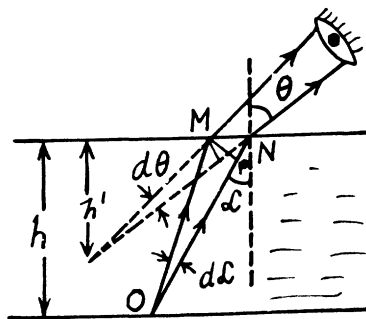

$$\sin \alpha = \frac{\sin \theta}{n}, \text{ so, } \cos \alpha = \sqrt{\frac{n^2 - \sin^2 \theta}{n^2}} \quad (\text{B})$$

Differentiating Eqn.(A)

$$n \cos \alpha d\alpha = \cos \theta d\theta \quad \text{or,} \quad \frac{d\alpha}{d\theta} = \frac{\cos \theta}{n \cos \alpha} \quad (4)$$

Using (4) in (3), we get

$$h' = \frac{h \cos^3 \theta}{n \cos^3 \alpha} \quad (5)$$

$$\text{Hence } h' = \frac{h \cos^3 \theta}{n \left(\frac{n^2 - \sin^2 \theta}{n^2} \right)^{3/2}} = \frac{n^2 h \cos^3 \theta}{(n^2 - \sin^2 \theta)^{3/2}} \quad [\text{Using Eqn.(B)}]$$

5.19 The figure shows the passage of a monochromatic ray through the given prism, placed in air medium.

From the figure, we have

$$\theta = \beta_1 + \beta_2 \quad (\text{A})$$

$$\text{and } \alpha = (\alpha_1 + \alpha_2) - (\beta_1 + \beta_2)$$

$$\alpha = (\alpha_1 + \alpha_2) - \theta \quad (1)$$

From the Snell's law

$$\sin \alpha_1 = n \sin \beta_1$$

$$\text{or} \quad \alpha_1 = n \beta_1 \quad (\text{for small angles}) \quad (2)$$

$$\text{and} \quad \sin \alpha_2 = n \sin \beta_2$$

$$\text{or,} \quad \alpha_2 = n \beta_2 \quad (\text{for small angles}) \quad (3)$$

From Eqns (1), (2) and (3), we get

$$\alpha = n(\beta_1 + \beta_2) - \theta$$

$$\text{So,} \quad \alpha = n(\theta) - \theta = (n - 1)\theta \quad [\text{Using Eqn.A}]$$

5.20 (a) In the general case, for the passage of a monochromatic ray through a prism as shown in the figure of the soln. of 5.19,

$$\alpha = (\alpha_1 + \alpha_2) - \theta \quad (1)$$

And from the Snell's law,

$$\sin \alpha_1 = n \sin \beta_1 \quad \text{or} \quad \alpha_1 = \sin^{-1}(n \sin \beta_1) \quad (2)$$

$$\text{Similarly } \alpha_2 = \sin^{-1}(n \sin \beta_2) = \sin^{-1}[n \sin(\theta - \beta_1)] \quad (\text{As } \theta = \beta_1 + \beta_2)$$

Using (2) in (1)

$$\alpha = \left[\sin^{-1}(n \sin \beta_1) + \sin^{-1}(n \sin(\theta - \beta_1)) \right] - \theta$$

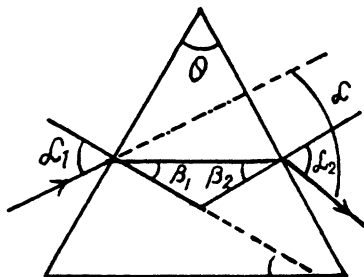

For α to be minimum, $\frac{d\alpha}{d\beta_1} = 0$

$$\text{or, } \frac{n \cos \beta_1}{\sqrt{1 - n^2 \sin^2 \beta_1}} - \frac{n \cos (\theta - \beta_1)}{\sqrt{1 - n^2 \sin^2 (\theta - \beta_1)}} = 0$$

$$\text{or, } \frac{\cos^2 \beta_1}{(1 - n^2 \sin^2 \beta_1)} = \frac{\cos^2 (\theta - \beta_1)}{1 - n^2 \sin^2 (\theta - \beta_1)}$$

$$\text{or, } \cos^2 \beta_1 (1 - n^2 \sin^2 (\theta - \beta_1)) = \cos^2 (\theta - \beta_1) (1 - n^2 \sin^2 \beta_1)$$

$$\text{or, } (1 - \sin^2 \beta_1) (1 - n^2 \sin^2 (\theta - \beta_1)) = (1 - \sin^2 (\theta - \beta_1)) (1 - n^2 \sin^2 \beta_1)$$

$$\begin{aligned} \text{or, } & 1 - n^2 \sin^2 (\theta - \beta_1) - \sin^2 \beta_1 + \sin^2 \beta_1 n^2 \sin^2 (\theta - \beta_1) \\ & = 1 - n^2 \sin^2 \beta_1 - \sin^2 (\theta - \beta_1) + \sin^2 \beta_1 n^2 \sin^2 (\theta - \beta_1) \end{aligned}$$

$$\text{or, } \sin^2 (\theta - \beta_1) - n^2 \sin^2 (\theta - \beta_1) = \sin^2 \beta_1 (1 - n^2)$$

$$\text{or, } \sin^2 (\theta - \beta_1) (1 - n^2) = \sin^2 \beta_1 (1 - n^2)$$

$$\text{or, } \theta - \beta_1 = \beta_1 \quad \text{or} \quad \beta_1 = \theta/2$$

$$\text{But } \beta_1 + \beta_2 = \theta, \quad \text{so, } \beta_2 = \theta/2 = \beta_1$$

which is the case of symmetric passage of ray.

In the case of symmetric passage of ray

$$\alpha_1 = \alpha_2 = \alpha' \quad (\text{say})$$

$$\text{and } \beta_1 = \beta_2 = \beta = \theta/2$$

Thus the total deviation

$$\alpha = (\alpha_1 + \alpha_2) - \theta$$

$$\alpha = 2\alpha' - \theta \quad \text{or} \quad \alpha' = \frac{\alpha + \theta}{2} \quad (1)$$

But from the Snell's law $\sin \alpha = n \sin \beta$

$$\text{So, } \sin \frac{\alpha + \theta}{2} = n \sin \frac{\theta}{2}$$

5.21 In this case we have

$$\sin \frac{\alpha + \theta}{2} = n \sin \frac{\theta}{2} \quad (\text{see soln. of 5.20})$$

In our problem $\alpha = \theta$

$$\text{So, } \sin \theta = n \sin (\theta/2) \quad \text{or} \quad 2 \sin (\theta/2) \cos (\theta/2) = n \sin (\theta/2)$$

$$\text{Hence } \cos (\theta/2) = \frac{n}{2} \quad \text{or} \quad \theta = 2 \cos^{-1} (n/2) = 83^\circ, \quad \text{where } n = 1.5$$

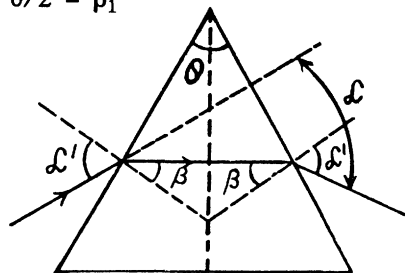

5.22 In the case of minimum deviation

$$\sin \frac{\alpha + \theta}{2} = n \sin \frac{\theta}{2}$$

$$\text{So, } \alpha = 2 \sin^{-1} \left\{ n \sin \frac{\theta}{2} \right\} - \theta = 37^\circ, \text{ for } n = 1.5$$

Passage of ray for grazing incidence and grazing emergence is the condition for maximum deviation (Fig.). From Fig.

$$\alpha = \pi - \theta = \pi - 2 \theta_{cr}$$

(where θ_{cr} is the critical angle)

$$\text{So, } \alpha = \pi - 2 \sin^{-1}(1/n) = 58^\circ, \\ \text{for } n = 1.5 = \text{R.I. of glass.}$$

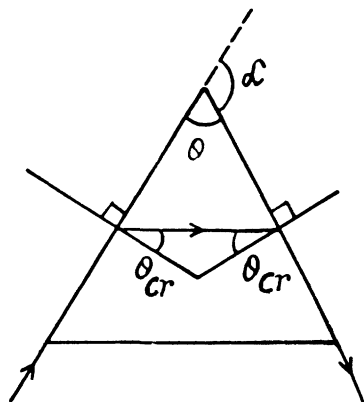

5.23 The least deflection angle is given by the formula,

$\delta = 2\alpha - \theta$, where α is the angle of incidence at first surface and θ is the prism angle.

Also from Snell's law, $n_1 \sin \alpha = n_2 \sin (\theta/2)$, as the angle of refraction at first surface is equal to half the angle of prism for least deflection

$$\text{so, } \sin \alpha = \frac{n_2}{n_1} \sin (\theta/2) = \frac{1.5}{1.33} \sin 30^\circ = .5639$$

$$\text{or, } \alpha = \sin^{-1}(.5639) = 34.3259^\circ$$

Substituting in the above (1), we get, $\delta = 8.65^\circ$

5.24 From the Cauchy's formula, and also experimentally the R.I. of a medium depends upon the wavelength of the monochromatic ray i.e. $n = f(\lambda)$. In the case of least deviation of a monochromatic ray the passage a prism, we have:

$$n \sin \frac{\theta}{2} = \sin \frac{\alpha + \theta}{2} \quad (1)$$

The above equation tales us that we have $n = n(\alpha)$, so we may write

$$\Delta n = \frac{dn}{d\alpha} \Delta \alpha \quad (2)$$

From Eqn. (1)

$$dn \sin \frac{\theta}{2} = \frac{1}{2} \cos \frac{\alpha + \theta}{2} d\alpha$$

$$\text{or, } \frac{dn}{d\alpha} = \frac{\cos \frac{\alpha + \theta}{2}}{2 \sin \frac{\theta}{2}} \quad (3)$$

From Eqns (2) and (3)

$$\Delta n = \frac{\cos \frac{\alpha + \theta}{2}}{2 \sin \frac{\theta}{2}} \Delta \alpha$$

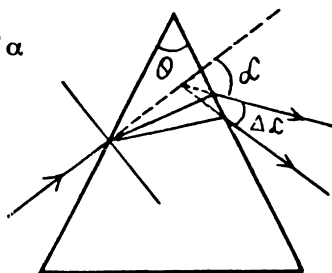

$$\text{or, } \Delta n = \frac{\sqrt{1 - \sin^2\left(\frac{\alpha + \theta}{2}\right)}}{2 \sin \frac{\theta}{2}} \Delta \alpha = \frac{\sqrt{1 - n^2 \sin^2 \frac{\theta}{2}}}{2 \sin \frac{\theta}{2}} \Delta \alpha \quad (\text{Using Eqn. 1.})$$

$$\text{Thus } \Delta \alpha = \frac{2 \sin \frac{\theta}{2}}{\sqrt{1 - n^2 \sin^2 \frac{\theta}{2}}} \Delta n = 0.44$$

5.25 Fermat's principle : " The actual path of propagation of light (trajectory of a light ray) is the path which can be followed by light with in the lest time, in comparison with all other hypothetical paths between the same two points. "

"Above statement is the original wordings of Fermat (A famous French scientist of 17th century)"

Deduction of the law of refraction from Fermat's principle :

Let the plane S be the interface between medium 1 and medium 2 with the refractive indices $n_1 = c/v_1$ and $n_2 = c/v_2$ Fig. (a). Assume, as usual, that $n_1 < n_2$. Two points are given- one above the plane S (point A), the other under plane S (point B). The various distances are :

$AA_1 = h_1$, $BB_1 = h_2$, $A_1B_1 = l$. We must find the path from A to B which can be covered by light faster than it can cover any other hypothetical path. Clearly, this path must consist of two straight lines, viz, AO in medium 1 and OB in medium 2; the point O in the plane S has to be found.

First of all, it follows from Fermat's principle that the point O must lie on the intersection of S and a plane P , which is perpendicular to S and passes through A and B .

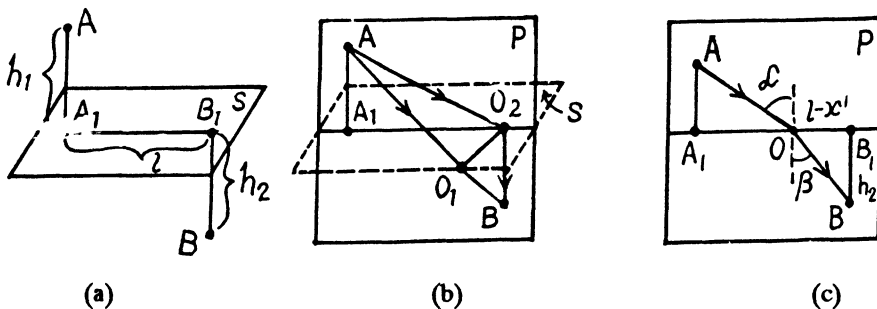

Indeed, let us assume that this point does not lie in the plane P , let this be point O_1 in Fig. (b). Drop the perpendicular O_1O_2 from O_1 onto P . Since $AO_2 < AO_1$ and $BO_2 < BO_1$, it is clear that the time required to traverse AO_2B is less than that needed to cover the path AO_1B . Thus, using Fermat's principle, we see that the first law of refraction is observed : the incident and the refracted rays lie in the same plane as the perpendicular to the interface at the point

where the ray is refracted. This plane is the plane P in Fig. (b); it is called the plane of incidence.

Now let us consider light rays in the plane of incidence Fig. (c). Designate A_1O as x and $OB_1 = l - x$. The time it takes a ray to travel from A to O and then from O to B is

$$T = \frac{AO}{v_1} + \frac{OB}{v_2} = \frac{\sqrt{h_1^2 + x^2}}{v_1} + \frac{\sqrt{h_2^2 + (l-x)^2}}{v_2} \quad (1)$$

The time depends on the value of x . According to Fermat's principle, the value of x must minimize the time T . At this value of x the derivative dT/dx equals zero :

$$\frac{dT}{dx} = \frac{x}{v_1 \sqrt{h_1^2 + x^2}} - \frac{l-x}{v_2 \sqrt{h_2^2 + (l-x)^2}} = 0. \quad (2)$$

Now,

$$\frac{x}{\sqrt{h_1^2 + x^2}} = \sin \alpha, \text{ and } \frac{l-x}{\sqrt{h_2^2 + (l-x)^2}} = \sin \beta,$$

Consequently,

$$\frac{\sin \alpha}{v_1} - \frac{\sin \beta}{v_2} = 0, \text{ or } \frac{\sin \alpha}{\sin \beta} = \frac{v_1}{v_2}$$

$$\text{So, } \frac{\sin \alpha}{\sin \beta} = \frac{c/n_1}{c/n_2} = \frac{n_2}{n_1}$$

Note : Fermat himself could not use Eqn. 2. as mathematical analysis was developed later by Newton and Leibniz. To deduce the law of the refraction of light, Fermat used his own maximum and minimum method of calculus, which, in fact, corresponded to the subsequently developed method of finding the minimum (maximum) of a function by differentiating it and equating the derivative to zero.

- 5.26 (a)** Look for a point O' on the axis such that $O'P'$ and $O'P$ make equal angles with $O'O$. This determines the position of the mirror. Draw a ray from P parallel to the axis. This must on reflection pass through F . The intersection of the reflected ray with principal axis determines the focus.

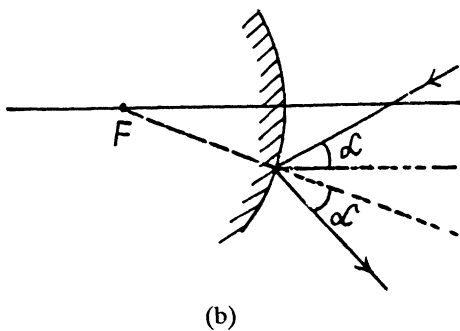
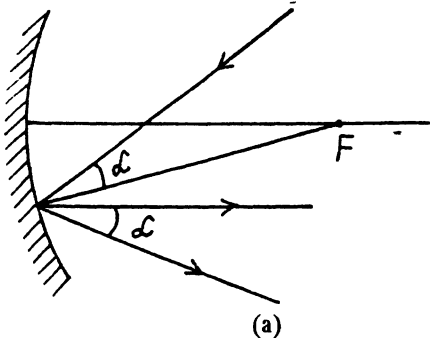

- (b) Suppose P is the object and P' is the image. Then the mirror is convex because the image is virtual, erect & diminished. Look for a point X (between P & P') on the axis such that PX and $P'X$ make equal angle with the axis.

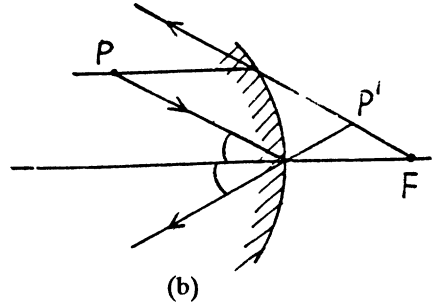
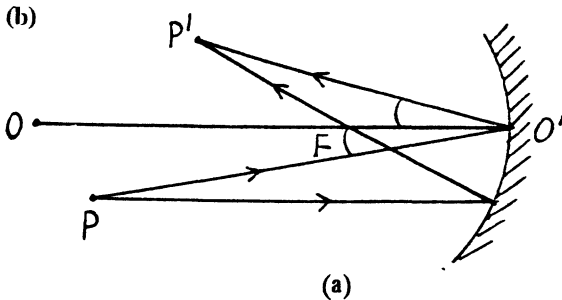

- 5.27 (a) From the mirror formula,

$$\frac{1}{s'} + \frac{1}{s} = \frac{1}{f} \quad \text{we get} \quad f = \frac{s's}{s'+s} \quad (1)$$

In accordance with the problem $s - s' = l \quad \frac{s'}{s} = \beta$,

From these two relations, we get : $s = \frac{l}{1-\beta}$, $s' = -\frac{l\beta}{1+\beta}$

Substituting it in the Eqn. (1),

$$f = \frac{\beta \left(\frac{l}{1-\beta} \right)^2}{l \left(\frac{1-\beta}{1-\beta} \right)} = \frac{l\beta}{(1-\beta^2)} = -10 \text{ cm}$$

- (b) Again we have, $\frac{1}{s'} + \frac{1}{s} = \frac{1}{f}$ or, $\frac{s}{s'} + 1 = \frac{s}{f}$

or, $\frac{1}{\beta_1} = \frac{s}{f} - 1 = \frac{s-f}{f}$

or, $\beta_1 = \frac{f}{s-f} \quad (2)$

Now, it is clear from the above equation, that for smaller β , s must be large, so the object is displaced away from the mirror in second position.

i.e. $\beta_2 = \frac{f}{s+l-f} \quad (3)$

Eliminating s from the Eqn. (2) and (3), we get,

$$f = \frac{l\beta_1\beta_2}{(\beta_2 - \beta_1)} = -2.5 \text{ cm}.$$

5.28 For a concave mirror as usual $\frac{1}{s'} + \frac{1}{s} = \frac{1}{f}$ so $s' = \frac{sf}{s-f}$

(In coordinate convention $s = -s$ is negative & $f = -|f|$ is also negative.)

If A is the area of the mirror (assumed small) and the object is on the principal axis, then the light incident on the mirror per second is $I_0 \frac{A}{s^2}$.

This follows from the definition of luminous intensity as light emitted per second per unit solid angle in a given direction and the fact that $\frac{A}{s^2}$ is the solid angle subtended by the mirror at the source. Of this a fraction ρ is reflected so if I is the luminous intensity of the image, then $I \frac{A}{s'^2} = \rho I_0 \frac{A}{s^2}$

Hence
$$I = \rho I_0 \left(\frac{|f|}{|f| - s} \right)^2$$

(Because our convention makes f -ve for a concave mirror, we have to write $|f|$.)

Substitution gives
$$I = 2.0 \times 10^3 \text{ cd.}$$

5.29 For O_1 to be the image, the optical paths of all rays $OA O_1$ must be equal upto terms of leading order in h . Thus

$$n_1 OA + n_2 A O_1 = \text{constant}$$

But, $OP = |s|$, $O_1 P = |s'|$ and so

$$OA = \sqrt{h^2 + (|s| + \delta)^2} \approx |s| + \delta + \frac{h^2}{2|s|}$$

$$O_1 A = \sqrt{h^2 + (|s'| - \delta)^2} \approx |s'| - \delta + \frac{h^2}{2|s'|}$$

(neglecting products $h^2 \delta$). Then

$$n_1 |s| + n_2 |s'| + n_1 \delta - n_2 \delta + \frac{h^2}{2} \left(\frac{n_1}{|s|} + \frac{n_2}{|s'|} \right) = \text{Const.}$$

$$\text{Now } (r - \delta)^2 + h^2 = r^2$$

$$\text{or } h^2 = 2r\delta \quad \text{or } \delta = \frac{h^2}{2r}$$

Here $r = CP$.

$$\text{Hence } n_1 |s| + n_2 |s'| + \frac{h^2}{2} \left\{ \frac{n_1 - n_2}{r} + \frac{n_1}{|s|} + \frac{n_2}{|s'|} \right\} = \text{Constant}$$

Since this must hold for all h , we have

$$\frac{n_2}{|s'|} + \frac{n_1}{|s|} = \frac{n_2 - n_1}{r}$$

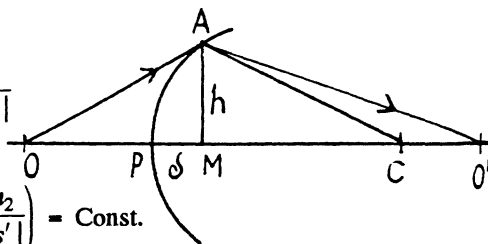

From our sign convention, $s' > 0$, $s < 0$ so we get

$$\frac{n_2}{s'} - \frac{n_1}{s} = \frac{n_2 - n_1}{r}$$

5.30 All rays focusing at a point must have traversed the same optical path. Thus

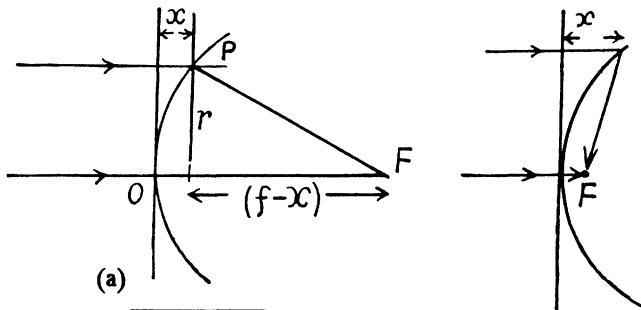

$$x + n\sqrt{r^2 + (f-x)^2} = nf \quad \text{or} \quad (nf-x)^2 = n^2 r^2 + n^2 (f-x)^2$$

$$\begin{aligned} \text{or,} \quad n^2 r^2 &= (nf-x)^2 - [n(f-x)]^2 = (nf-x+nf-nx)(nf-x-nf+nx) \\ &= x(n-1)(2nf-(n+1)x) \\ &= 2n(n-1)fx - (n+1)(n-1)x^2 \end{aligned}$$

$$\text{Thus,} \quad (n+1)(n-1)x^2 - 2n(n-1)fx + n^2 r^2 = 0$$

$$\text{so,} \quad x = \frac{n(n-1)f \pm \sqrt{n^2(n-1)^2 f^2 - n^2 r^2 (n+1)(n-1)}}{(n+1)(n-1)}$$

$$= \frac{nf}{n+1} \left[1 \pm \sqrt{1 - \frac{n+1}{n-1} \frac{r^2}{f^2}} \right]$$

Ray must move forward so $x < f$, for + sign $x > f$ for small r , so -sign.

(Also $x \rightarrow 0$ as $r \rightarrow 0$)

($x > f$ means ray turning back in the direction of incidence. (see Fig.)

$$\text{Hence} \quad x = \frac{nf}{n+1} \left[1 - \sqrt{1 - \frac{n+1}{n-1} \frac{r^2}{f^2}} \right]$$

For the maximum value of r ,

$$\sqrt{1 - \frac{n+1}{n-1} \frac{r^2}{f^2}} = 0 \quad (\text{A})$$

because the expression under the radical sign must be non-negative, which gives the maximum value of r .

$$\text{Hence from Eqn. (A),} \quad r_{\max} = f \sqrt{(n-1)/(n+1)}$$

5.31 As the given lens has significant thickness, the thin lens, formula cannot be used.

For refraction at the front surface from the formula $\frac{n'}{s'} - \frac{n}{s} = \frac{n' - n}{R}$

$$\frac{1.5}{s'} - \frac{1}{-20} = \frac{1.5 - 1}{5}$$

On simplifying we get, $s' = 30$ cm.

Thus the image I' produced by the front surface behaves as a virtual source for the rear surface at distance 25 cm from it, because the thickness of the lens is 5 cm. Again from the refraction formula at curve surface

$$\frac{n'}{s'} - \frac{n}{s} = \frac{n' - n}{R}$$

$$\frac{1}{s'} - \frac{1.5}{25} = \frac{1 - 1.5}{-5}$$

On simplifying, $s' = +6.25$ cm

Thus we get a real image I at a distance 6.25 cm beyond the rear surface (Fig.).

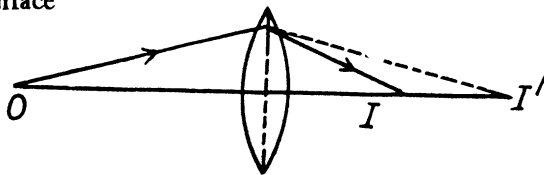

- 5.32 (a) The formation of the image of a source S , placed at a distance u from the pole of the convex surface of plano-convex lens of thickness d is shown in the figure.

On applying the formula for refraction through spherical surface, we get

$$\frac{n}{s'} - \frac{1}{s} = (n - 1)/R, \text{ (here } n_2 = n \text{ and } n_1 = 1)$$

$$\text{or, } \frac{n}{d} - \frac{1}{s} = (n - 1)/R \quad \text{or, } \frac{1}{s} = \frac{n}{d} - \frac{(n - 1)}{R}$$

$$\text{or, } \frac{s'}{s} = s' \left\{ \frac{n}{d} - \frac{(n - 1)}{R} \right\}$$

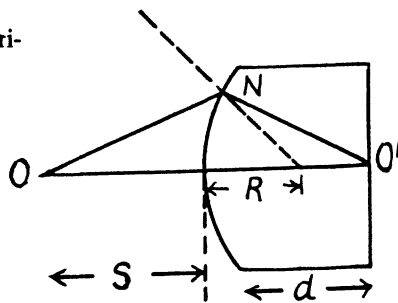

But in this case optical path of the light, corresponding to the distance v in the medium is v/n , so the magnification produced will be,

$$\beta = \frac{s'}{ns} = \frac{s'}{n} \left\{ \frac{n}{d} - \frac{(n - 1)}{R} \right\} = \frac{d}{n} \left\{ \frac{n}{d} - \frac{(n - 1)}{R} \right\} = 1 - \frac{d(n - 1)}{nR}$$

Substituting the values, we get magnification $\beta = -0.20$.

- (b) If the transverse area of the object is A (assumed small), the area of the image is $\beta^2 A$.

We shall assume that $\frac{\pi D^2}{4} > A$. Then light falling on the lens is : $LA \frac{\pi D^2}{4s^2}$

from the definition of luminance (See Eqn. (5.1c) of the book; here

$\cos \theta \approx 1$ if $D^2 \ll s^2$ and $d\Omega = \frac{\pi D^2/4}{s^2}$). Then the illuminance of the image is

$$L A \frac{\pi D^2/4}{s^2} / \beta^2 A = L n^2 \pi D^2/4d^2$$

Substitution gives 42 1x.

5.33 (a) Optical power of a thin lens of R.I. n in a medium with R.I. n_0 is given by :

$$\Phi = (n - n_0) \left(\frac{1}{R_1} - \frac{1}{R_2} \right) \quad (\text{A})$$

From Eqn.(A), when the lens is placed in air :

$$\Phi_0 = (n - 1) \left(\frac{1}{R_1} - \frac{1}{R_2} \right) \quad (1)$$

Similarly from Eqn.(A), when the lens is placed in liquid :

$$\Phi = (n - n_0) \left(\frac{1}{R_1} - \frac{1}{R_2} \right) \quad (2)$$

Thus from Eqns (1) and (2)

$$\Phi = \frac{n - n_0}{n - 1} \Phi_0 = 2D$$

The second focal length, is given by

$f' = \frac{n'}{\Phi}$, where n' is the R.I. of the medium in which it is placed.

$$f' = \frac{n_0}{\Phi} = 85 \text{ cm}$$

(b) Optical power of a thin lens of R.I. n placed in a medium of R.I. n_0 is given by :

$$\Phi = (n - n_0) \left(\frac{1}{R_1} - \frac{1}{R_2} \right) \quad (\text{A})$$

For a biconvex lens placed in air medium from Eqn. (A)

$$\Phi_0 = (n - 1) \left(\frac{1}{R} - \frac{1}{-R} \right) = \frac{2(n - 1)}{R} \quad (1)$$

where R is the radius of each curve surface of the lens

Optical power of a spherical refractive surface is given by :

$$\Phi = \frac{n' - n}{R} \quad (\text{B})$$

For the rear surface of the lens which divides air and glass medium

$$\Phi_0 = \frac{n - 1}{R} \text{ (Here } n \text{ is the R.I. (2) of glass)}$$

Similarly for the front surface which divides water and glass medium

$$\Phi_l = \frac{n - n_0}{-R} = \frac{n - n_0}{R} \quad (3)$$

Hence the optical power of the given optical system

$$\Phi = \Phi_a + \Phi_l = \frac{n-1}{R} + \frac{n-n_0}{R} = \frac{2n-n_0-1}{R} \quad (4)$$

From Eqns (1) and (4)

$$\frac{\Phi}{\Phi_0} = \frac{2n-n_0-1}{2(n-1)} \quad \text{So} \quad \Phi = \frac{(2n-n_0-1)}{2(n-1)} \Phi_0$$

Focal length in air, $f = \frac{1}{\Phi} = 15 \text{ cm}$

and focal length in water = $\frac{n_0}{\Phi} = 20 \text{ cm}$ for $n_0 = \frac{4}{3}$.

- 5.34 (a) Clearly the media on the sides are different. The front focus F is the position of the object (virtual or real) for which the image is formed at infinity. The rear focus F' is the position of the image (virtual or real) of the object at infinity. (a) Figures 5.7 (a) & (b). This geometrical construction ensures that the second of the equations (5.1g) is obeyed.

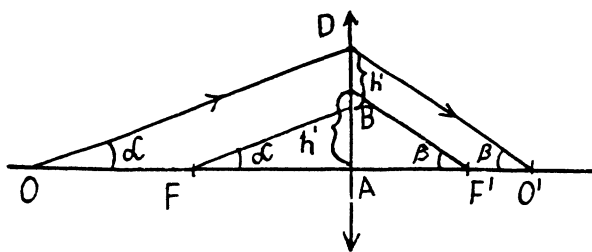

(a) Convex lens

(b) Figure 5.5 (a) & (b) with lens

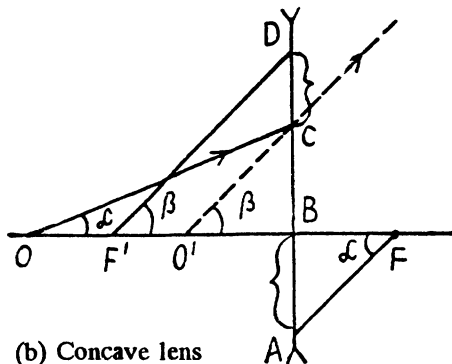

(b) Concave lens

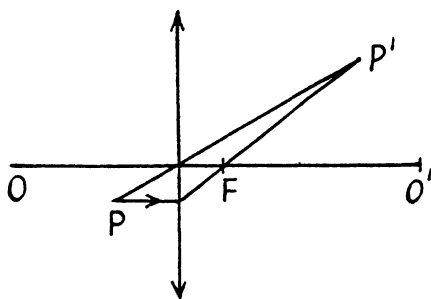

(a) Convex lens

(P is the object)

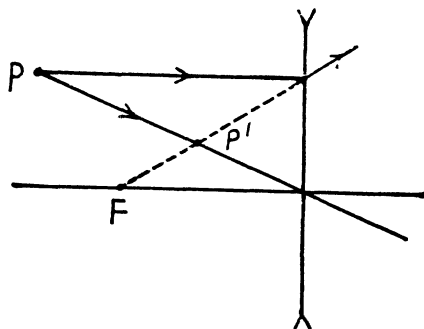

(b) Concave lens

(c) Figure (5.8) (a) & (b).

Clearly, the important case is that when the rays (1) & (2) are not symmetric about the principal axis, otherwise the figure can be completed by reflection in the principal axis. Knowing one path we know the path of all rays connecting the two points. For a different object. We proceed as shown below, we use the fact that a ray incident at a given height above the optic centre suffers a definite deviation.

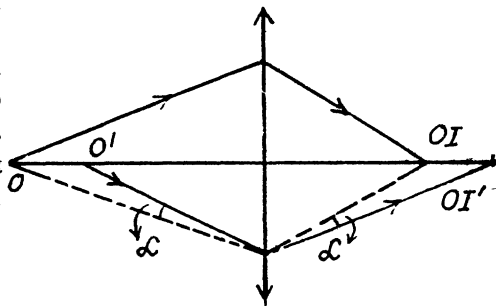

The concave lens can be discussed similarly.

5.35 Since the image is formed on the screen, it is real, so for a converging lens object is in the incident side.

Let s_1 and s_2 be the magnitudes of the object distance in the first and second case respectively. We have the lens formula

$$\frac{1}{s'} - \frac{1}{s} = \frac{1}{f} \quad (1)$$

In the first case from Eqn. (1)

$$\frac{1}{(+l)} - \frac{1}{(-s_1)} = \frac{1}{f} \quad \text{or, } s_1 = \frac{f(l)}{l-f} = 26.31 \text{ cm.}$$

Similarly from Eqn.(1) in the second case

$$\frac{1}{(l-\Delta l)} - \frac{1}{(-s_2)} = \frac{1}{f} \quad \text{or, } s_2 = \frac{l f}{(l-\Delta l)-f} = 26.36 \text{ cm.}$$

Thus the sought distance $\Delta x = s_2 - s_1 = 0.5 \text{ mm} \approx \Delta l f^2 / (l - f^2)$

5.36 The distance between the object and the image is l . Let x = distance between the object and the lens. Then, since the image is real, we have in our convention, $u = -x$, $v = l - x$

$$\text{so} \quad \frac{1}{x} + \frac{1}{l-x} = \frac{1}{f}$$

$$\text{or} \quad x(l-x) = lf \quad \text{or } x^2 - xl + lf = 0$$

Solving we get the roots

$$x = \frac{1}{2} \left[l \pm \sqrt{l^2 - 4lf} \right]$$

(We must have $l > 4f$ for real roots.)

(a) If the distance between the two positions of the lens is Δl , then clearly $\Delta l = x_2 - x_1$ = difference between roots = $\sqrt{l^2 - 4lf}$

$$\text{so} \quad f = \frac{l^2 - \Delta l^2}{4l} = 20 \text{ cm.}$$

- (b) The two roots are conjugate in the sense that if one gives the object distance the other gives the corresponding image distance (in both cases). Thus the magnifications are

$$-\frac{l + \sqrt{l^2 - 4lf}}{l - \sqrt{l^2 - 4lf}} \text{ (enlarged) and } -\frac{l - \sqrt{l^2 - 4lf}}{l + \sqrt{l^2 - 4lf}} \text{ (diminished).}$$

The ratio of these magnification being η we have

$$\frac{l - \sqrt{l^2 - 4lf}}{l - \sqrt{l^2 - 4lf}} = \sqrt{\eta} \quad \text{or} \quad \frac{\sqrt{l^2 - 4lf}}{l} = \frac{\sqrt{\eta} - 1}{\sqrt{\eta} + 1}$$

or

$$1 - \frac{4f}{l} = \left(\frac{\sqrt{\eta} - 1}{\sqrt{\eta} + 1} \right)^2 = 1 - 4 \frac{\sqrt{\eta}}{(1 + \sqrt{\eta})^2}$$

Hence

$$f = l \frac{\sqrt{\eta}}{(1 + \sqrt{\eta})^2} = 20 \text{ cm.}$$

- 5.37 We know from the previous problem that the two magnifications are reciprocals of each other ($\beta' \beta'' = 1$). If h is the size of the object then $h' = \beta' h$ and

$$h'' = \beta'' h$$

Hence

$$h = \sqrt{h' h''}.$$

- 5.38 Refer to problem 5.32 (b). If A is the area of the object, then provided the angular diameter of the object at the lens is much smaller than other relevant angles like $\frac{D}{f}$ we calculate the

light falling on the lens as $LA \frac{\pi D^2}{4 s^2}$

where u^2 is the object distance squared. If β is the transverse magnification ($\beta = \frac{s'}{u}$) then the area of the image is $\beta^2 A$. Hence the illuminance of the image (also taking account of the light lost in the lens)

$$E = (1 - \alpha) LA \frac{\pi D^2}{4 s^2} \frac{1}{\beta^2 A} = \frac{(1 - \alpha) \pi D^2 L}{4 f^2}$$

since $s' = f$ for a distant object. Substitution gives $E = 15 \text{ lx}$.

- 5.39 (a) If s = object distance, s' = average distance, L = luminance of the source, ΔS = area of the source assumed to be a plane surface held normal to the principal axis, then we find for the flux $\Delta \Phi$ incident on the lens

$$\Delta \Phi = \int L \Delta S \cos \theta d\Omega$$

$$\approx L \Delta S \int_0^{\infty} \cos \theta 2\pi \sin \theta d\theta = L \Delta S \pi \sin^2 \alpha = L \Delta S \frac{\pi D^2}{4 s^2}$$

Here we are assuming $D \ll s$, and ignoring the variation of L since α is small

Then if L' is the luminance of the image, and $\Delta S' = \left(\frac{S'}{S}\right)^2 \Delta S$ is the area of the image then similarly

$$L' \Delta S' \frac{D^2}{4 s'^2} \pi = L' \Delta S \frac{D^2}{4 s^2} \pi = L \Delta S \frac{D^2}{4 s^2} \pi$$

or $L' = L$ irrespective of D .

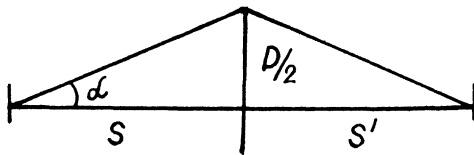

- (b) In this case the image on the white screen from a Lambert source. Then if its luminance is L_0 its luminosity will be the πL_0 and

$$\pi L_0 \frac{s'^2}{s^2} \Delta S = L \Delta S \frac{D^2}{4 s^2} \pi$$

or $L_0 \propto D^2$

since s' depends on f, s but not on D .

- 5.40** Focal length of the converging lens, when it is submerged in water of R.I. n_0 (say) :

$$\frac{1}{f_1} = \left(\frac{n_1}{n_0} - 1\right) \left(\frac{1}{R} - \frac{1}{R}\right), \frac{2(n_1 - n_0)}{n_0 R} \quad (1)$$

Similarly, the focal length of diverging lens in water.

$$\frac{1}{f_2} = \left(\frac{n_2}{n_0} - 1\right) \left(\frac{1}{-R} - \frac{1}{R}\right) = \frac{-2(n_2 - n_0)}{n_0 R} \quad (2)$$

Now, when they are put together in the water, the focal length of the system,

$$\begin{aligned} \frac{1}{f} &= \frac{1}{f_1} + \frac{1}{f_2} \\ &= \frac{2(n_1 - n_2)}{n_0 R} - \frac{2(n_2 - n_0)}{n_0 R} = \frac{2(n_1 - n_2)}{n_0 R} \end{aligned}$$

or,

$$f = \frac{-n_0 R}{2(n_1 - n_2)} = 35 \text{ cm}$$

- 5.41** C is the centre of curvature of the silvered surface and O is the effective centre of the equivalent mirror in the sense that an object at O forms a coincident image. From the figure, using the formula for refraction at a spherical surface, we have

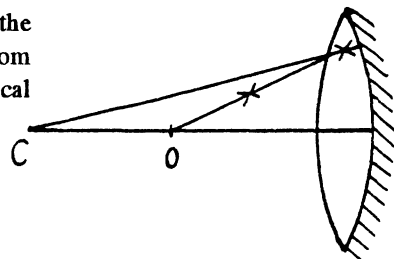

$$\frac{n}{-R} - \frac{1}{2f} = \frac{n - 1}{R} \quad \text{or} \quad f = \frac{-R}{2(2n - 1)}$$

(In our convention f is $-ve$).

Substitution gives $f = -10 \text{ cm}$.

- 5.42 (a) Path of a ray, as it passes through the lens system is as shown below.

Focal length of all the three lenses,

$$f = \frac{1}{10} \text{ m} = 10 \text{ cm, neglecting their signs.}$$

Applying lens formula for the first lens, considering a ray coming from infinity,

$$\frac{1}{s'} - \frac{1}{\infty} = \frac{1}{f} \quad \text{or, } s' = f = 10 \text{ cm,}$$

and so the position of the image is 5 cm to the right of the second lens, when only the first one is present, but the ray again gets refracted while passing through the second, so,

$$\frac{1}{s'} - \frac{1}{5} = \frac{1}{f} = \frac{1}{-10}$$

or, $s' = 10 \text{ cm}$, which is now 5 cm left to the third lens so for this lens,

$$\frac{1}{s''} - \frac{1}{5} = \frac{1}{10} \quad \text{or } \frac{1}{s''} = \frac{3}{10}$$

or,

$$s'' = 10/3 = 3.33 \text{ cm. from the last lens.}$$

(b) This means that if the object is $x \text{ cm}$ to be left of the first lens on the axis OO' then the image is $x \text{ cm}$ on to the right of the 3rd (last) lens. Call the lenses 1,2,3 from the left and let O be the object, O_1 its image by the first lens, O_2 the image of O_1 by the 2nd lens and O_3 , the image of O_2 by the third lens.

O_1 and O_2 must be symmetrically located with respect to the lens L_2 and since this lens is concave, O_1 must be at a distance $2|f_2|$ to be the right of L_2 and O_2 must be $2|f_2|$ to be the left of L_2 . One can check that this satisfies lens equation for the third lens L_3

$$u = -(2|f_2| + 5) = -25 \text{ cm.}$$

$$s' = x, \quad f_3 = 10 \text{ cm.}$$

Hence
$$\frac{1}{x} + \frac{1}{25} = \frac{1}{10} \text{ so } x = 16.67 \text{ cm.}$$

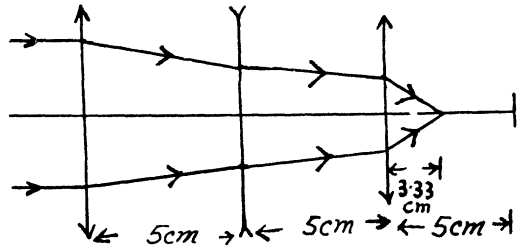

(a)

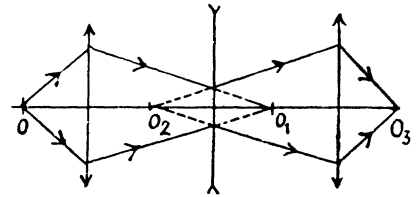

(b)

- 5.43 (a) Angular magnification for Galilean telescope in normal adjustment is given as.

$$\Gamma = f_o/f_e$$

or,

$$10 = f_o/f_e \quad \text{or } f_o = 10 f_e$$

(1)

The length of the telescope in this case.

$$l = f_o - f_e = 45 \text{ cm. given,}$$

So, using (1), we get,

$$f_e = +5 \text{ and } f_o = +50 \text{ cm.}$$

(b) Using lens formula for the objective,

$$\frac{1}{s'_o} + \frac{1}{s_o} = \frac{1}{f_o} \text{ or, } s'_o = \frac{s_o f_o}{s_o + f_o} = 50.5 \text{ cm}$$

From the figure, it is clear that,

$s'_o = l' + f_e$ where l' is the new tube length.

$$\text{or, } l' = s'_o - f_e = 50.5 - 5 = 45.5 \text{ cm.}$$

So, the displacement of ocular is,

$$\Delta l = l' - l = 45.5 - 45 = 0.5 \text{ cm}$$

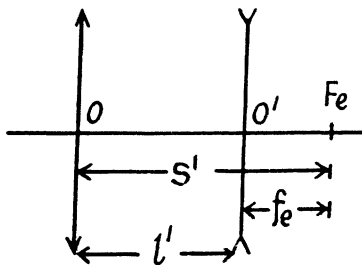

- 5.44 In the Keplerian telescope, in normal adjustment, the distance between the objective and eyepiece is $f_o + f_e$. The image of the mounting produced by the eyepiece is formed at a distance v to the right where

$$\frac{1}{s'} - \frac{1}{s} = \frac{1}{f_e}$$

But

$$s = -(f_o + f_e),$$

so

$$\frac{1}{s'} = \frac{1}{f_e} - \frac{1}{f_o + f_e} = \frac{f_o}{f_e(f_o + f_e)}$$

The linear magnification produced by the eyepiece of the mounting is, in magnitude,

$$|\beta| = \left| \frac{s'}{s} \right| = \frac{f_e}{f_o}$$

This equals $\frac{d}{D}$ according to the problem so

$$\Gamma = \frac{f_o}{f_e} = \frac{D}{d}.$$

- 5.45 It is clear from the figure that a parallel beam of light, originally of intensity I_0 has, on emerging from the telescope, an intensity.

$$I = I_0 \left(\frac{f_o}{f_e} \right)^2$$

because it is concentrated over a section whose diameter is f_e/f_o of the diameter of the cross section of the incident beam.

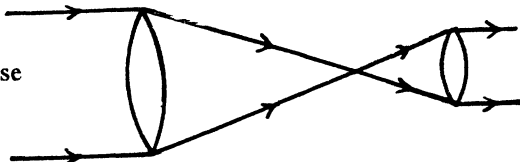

Thus
$$\eta = \left(\frac{f_0}{f_e} \right)^2$$

So
$$\Gamma = \frac{f_0}{f_e} = \sqrt{\eta}$$

Now
$$\Gamma = \frac{\tan \Psi'}{\tan \Psi} = \frac{\Psi'}{\Psi}$$

Hence $\Psi = \Psi'/\sqrt{\eta} = 0.6'$ on substitution.

- 5.46** When a glass lens is immersed in water its focal length increases approximately four times. We check this as follows as :

$$\frac{1}{f_a'} = (n - 1) \left(\frac{1}{R_1} - \frac{1}{R_2} \right)$$

$$\frac{1}{f_w} = \left(\frac{n}{n_0} - 1 \right) \left(\frac{1}{R_1} - \frac{1}{R_2} \right) = \frac{\frac{n}{n_0} - 1}{n - 1} \cdot \frac{1}{f_a} = \frac{n - n_0}{n_0(n - 1)} \frac{1}{f_a}$$

Now back to the problem. Originally in air

$$\Gamma = \frac{f_0}{f_e} = 15 \quad \text{so} \quad l = f_0 + f_e = f_e (\Gamma + 1)$$

In water,
$$f_e' = \frac{n_0(n - 1)}{n - n_0} f_e$$

and the focal length of the replaced objective is given by the condition

$$f_0' + f_e' = l = (\Gamma + 1) f_e$$

or
$$f_0' = (\Gamma + 1) f_e - f_e'$$

Hence
$$\Gamma' = \frac{f_0'}{f_e'} = (\Gamma + 1) \frac{n - n_0}{n_0(n - 1)} - 1$$

Substitution gives ($n = 1.5$, $n_0 = 1.33$), $\Gamma' = 3.09$

- 5.47** If L is the luminance of the object, A is its area, s = distance of the object then light falling on the objective is

$$\frac{L \pi D^2}{4 s^2} A$$

The area of the image formed by the telescope (assuming that the image coincides with the object) is $\Gamma^2 A$ and the area of the final image on the retina is

$$= \left(\frac{f}{s} \right)^2 \Gamma^2 A$$

Where f = focal length of the eye lens. Thus the illuminance of the image on the retina (when the object is observed through the telescope) is

$$\frac{L \pi D^2 A}{4 u^2 \left(\frac{L}{s}\right)^2 \Gamma^2 A} = \frac{L \pi D^2}{4 f^2 \Gamma^2}$$

When the object is viewed directly, the illuminance is, similarly, $\frac{L \pi d_0^2}{4 f^2}$

We want
$$\frac{L \pi D^2}{4 f^2 \Gamma^2} \geq \frac{L \pi d_0^2}{4 f^2}$$

So, $\Gamma \leq \frac{D}{d_0} = 20$ on substitution of the values.

5.48 Obviously, $f_o = +1$ cm and $f_e = +5$ cm

Now, we know that, magnification of a microscope,

$$\Gamma = \left(\frac{s'_o}{f_o} - 1\right) \frac{D}{f_e}, \text{ for distinct vision}$$

or,
$$50 = \left(\frac{s'_o}{1} - 1\right) \frac{25}{5} \text{ or, } v_o = 11 \text{ cm.}$$

Since distance between objective and ocular has increased by 2 cm, hence it will cause the increase of tube length by 2cm.

so,
$$s'_o = s'_o + 2 = 13$$

and hence, :
$$\Gamma' = \left(\frac{s'_o}{f_o} - 1\right) \frac{D}{f_e} = 60$$

5.49 It is implied in the problem that final image of the object is at infinity (otherwise light coming out of the eyepiece will not have a definite diameter).

(a) We see that $s'_o 2 \beta = |s_0| 2 \alpha$, then

$$\beta = \frac{|s_0|}{s'_o} \alpha$$

Then, from the figure

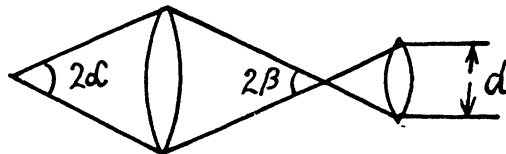

$$d = 2 f_e \beta = 2 f_e \alpha / \frac{s'_o}{|s_0|}$$

But when the final image is at infinity, the magnification Γ in a microscope is given by

$$\Gamma = \frac{s'_o}{|s_0|} \cdot \frac{l}{f_e} \text{ (} l = \text{least distance of distinct vision) So } d = 2 l \alpha / \Gamma$$

So $d = d_0$ when $\Gamma = \Gamma_0 = \frac{2 l \alpha}{d_0} = 15$ on putting the values.

(b) If Γ is the magnification produced by the microscope, then the area of the image produced on the retina (when we observe an object through a microscope) is : $\Gamma^2 \left(\frac{f}{s}\right)^2 A$

Where u = distance of the image produced by the microscope from the eye lens, f = focal length of the eye lens and A = area of the object. If Φ = luminous flux reaching the objective from the object and $d \leq d_0$ so that the entire flux is admitted into the eye), then the illuminance of the final image on the retina

$$= \frac{\Phi}{\Gamma^2 (f/s)^2 A}$$

But if $d \geq d_0^2$, then only a fraction $(d_0/d)^2$ of light is admitted into the eye and the illuminance becomes

$$\frac{\Phi}{A \left(\frac{f}{s}\right)^2 \Gamma^2} \left(\frac{d_0}{d}\right)^2 = \frac{\Phi d_0^2}{A \left(\frac{f}{s}\right)^2 (2l\alpha)^2}$$

independent of Γ . The condition for this is then

$$d \geq d_0 \quad \text{or} \quad \Gamma \leq \Gamma_0 = 15.$$

5.50 The primary and secondary focal length of a thick lens are given as,

$$f = -(n/\Phi) \{1 - (d/n') \Phi_2\}$$

and

$$f' = + (n''/\Phi) \{1 - (d/n') \Phi_1\},$$

where Φ is the lens power n , n' and n'' are the refractive indices of first medium, lens material and the second medium beyond the lens. Φ_1 and Φ_2 are the powers of first and second spherical surface of the lens.

Here,

$$n = 1, \text{ for lens, } n' = n, \text{ for air}$$

and

$$n'' = n_0, \text{ for water.}$$

So,

$$\left. \begin{aligned} f &= -1/\Phi_1 \\ \text{and } f' &= +n_0/\Phi \end{aligned} \right\}, \text{ as } d \approx 0, \quad (1)$$

Now, power of a thin lens,

$$\Phi = \Phi_1 + \Phi_2,$$

where,

$$\Phi_1 = \frac{(n-1)}{R}$$

and

$$\Phi_2 = \frac{(n_0-n)}{-R}$$

So,

$$\Phi = (2n - n_0 - 1)/R \quad (2)$$

From equations (1) and (2), we get,

$$f = \frac{-R}{(2n - n_0 - 1)} = -11.2 \text{ cm}$$

and
$$f = \frac{n_0 R}{(2n - n_0 - 1)} = +14.9 \text{ cm.}$$

Since the distance between the primary principal point and primary nodal point is given as,

So, in this case,
$$x = f \left\{ \frac{(n'' - n)}{n''} \right\}$$

$$x = (n_0/\Phi) (n_0 - 1)/n_0 = (n_0 - 1)/\Phi$$

$$= \frac{n_0}{\Phi} - \frac{1}{\Phi} = f + f = 3.7 \text{ cm.}$$

5.51 See the answersheet of problem book.

5.52 (a) Draw $P'X$ parallel to the axis OO' and let PF intersect it at X . That determines the principal point H . As the medium on both sides of the system is the same, the principal point coincides with the nodal point. Draw a ray parallel to PH through P' . That determines H' . Draw a ray PX' parallel to the axis and join $P'X'$. That gives F' .

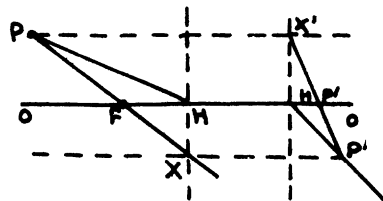

(a)

(b) We let H stand for the principal point (on the axis). Determine H' by drawing a ray $P'H'$ passing through P' and parallel to PH . One ray (conjugate to SH) can be obtained from this. To get the other ray one needs to know F or F' . This is easy because P and P' are known. Finally we get S' .

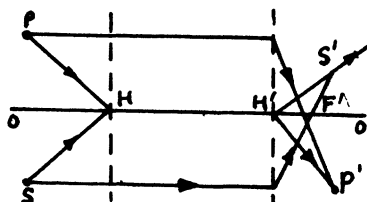

(b)

(c) From the incident ray we determine Q . A line parallel to OO' through Q determines Q' and hence H' . H and H' are then also the nodal points. A ray parallel to the incident ray through H will emerge parallel to itself through H' . That determines F' . Similarly a ray parallel to the emergent ray through H determines F .

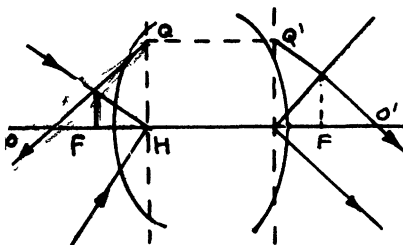

(c)

5.53 Here we do not assume that the media on the two sides of the system are the same.

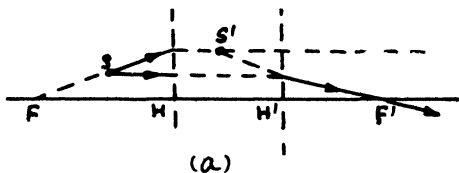

(a)

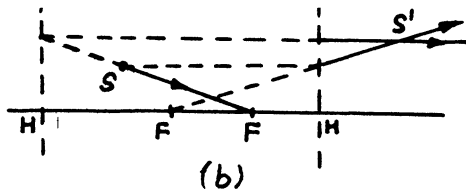

(b)

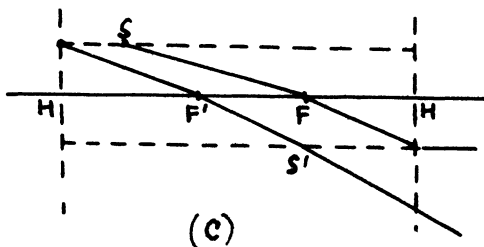

(c)

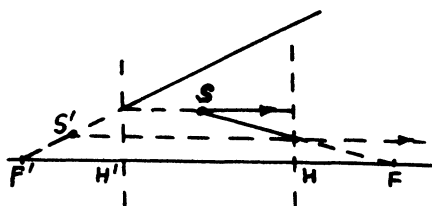

(d)

5.54 (a) Optical power of the system of combination of two lenses,

$$\Phi = \Phi_1 + \Phi_2 - d \Phi_1 \Phi_2$$

on putting the values,

$$\Phi = 4 \text{ D}$$

or,

$$f = \frac{1}{\Phi} = 25 \text{ cm}$$

Now, the position of primary principal plane with respect to the vertex of converging lens,

$$X = \frac{d \Phi_2}{\Phi} = 10 \text{ cm}$$

Similarly, the distance of secondary principal plane with respect to the vertex of diverging lens.

$$X' = -\frac{d \Phi_1}{\Phi} = -10 \text{ cm, i.e. } 10 \text{ cm left to it.}$$

(b) The distance between the rear principal focal point F' and the vertex of converging lens,

$$l = d + \left(\frac{1}{\Phi}\right)(-d \Phi_1) = \frac{\Phi d}{\Phi} + \left(\frac{-d \Phi_1}{\Phi}\right)$$

and

$$f/l = \left(\frac{1}{\Phi}\right) / \left(\frac{\Phi d}{\Phi} - \frac{d \Phi_1}{\Phi}\right), \text{ as } f = \frac{1}{\Phi}$$

$$= 1/d \Phi - d \Phi_1$$

$$= 1/d(\Phi_1 + \Phi_2 - d \Phi_1 \Phi_2) - d \Phi_1 = 1/d \Phi_2 - d^2 \Phi_1 \Phi_2$$

Now, if f/l is maximum for certain value of d then l/f will be minimum for the same value of d . And for minimum l/f ,

$$d(l/f)/dd = \Phi_2 - 2d \Phi_1 \Phi_2 = 0$$

or,

$$d = \Phi_2 / 2 \Phi_1 \Phi_2$$

or,

$$d = 1/2 \Phi_1 = 5 \text{ cm}$$

So, the required maximum ratio of $f/l = 4/3$.

5.55 The optical power of first convex surface is,

$$\Phi = \frac{P(n-1)}{R_1} = 5 \text{ D, as } R_1 = 10 \text{ cm}$$

and the optical power of second concave surface is,

$$\Phi_2 = \frac{(1-n)}{R_2} = -10 \text{ D}$$

So, the optical power of the system,

$$\Phi = \Phi_1 + \Phi_2 - \frac{d}{n} \Phi_1 \Phi_2 = -4D$$

Now, the distance of the primary principal plane from the vertex of convex surface is given as,

$$\begin{aligned} x &= \left(\frac{1}{\Phi}\right) \left(\frac{d}{n}\right) \Phi_2, \text{ here } n_1 = 1 \text{ and } n_2 = n. \\ &= \frac{d \Phi_2}{\Phi n} = 5 \text{ cm} \end{aligned}$$

and the distance of secondary principal plane from the vertex of second concave surface,

$$x' = -\left(\frac{1}{\Phi}\right) \left(\frac{d}{n}\right) \Phi_1 = -\frac{d \Phi_1}{\Phi n} = 2.5 \text{ cm}$$

5.56 The optical power of the system of two thin lenses placed in air is given as,

$$\Phi = \Phi_1 + \Phi_2 - d \Phi_1 \Phi_2$$

or, $\frac{1}{f} = \frac{1}{f_1} + \frac{1}{f_2} - \frac{d}{f_1 f_2}$, where f is the equivalent focal length

So,
$$\frac{1}{f} = \frac{f_2 + f_1 - d}{f_1 f_2}$$

or,
$$f = \frac{f_1 f_2}{f_1 + f_2 - d} \quad (1)$$

This equivalent focal length of the system of two lenses is measured from the primary principal plane.

As clear from the figure, the distance of the primary principal plane from the optical centre of the first is

$$O_1 H = x = + (n/\Phi) (d/n') \Phi_1$$

$$= \frac{d \Phi_1}{\Phi}, \text{ as } n = n' = 1, \text{ for air.}$$

$$= \frac{d f}{f_1}$$

$$= \left(\frac{d}{f_1}\right) \left(\frac{f_1 f_2}{f_1 + f_2 - d}\right)$$

$$= \frac{d f_2}{f_1 + f_2 - d}$$

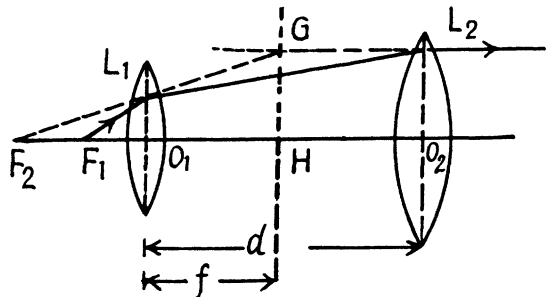

Now, if we place the equivalent lens at the primary principal plane of the lens system, it will provide the same transverse magnification as the system. So, the distance of equivalent lens from the vertex of the first lens is,

$$x = \frac{d f_2}{f_1 + f_2 - d}$$

5.57 The plane mirror forms the image of the lens, and water, filled in the space between the two, behind the mirror, as shown in the figure.

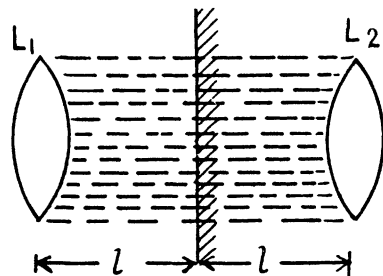

So, the whole optical system is equivalent to two similar lenses, separated by a distance $2l$ and thus, the power of this system,

$$\Phi = \Phi_1 + \Phi_2 - \frac{d \Phi_1 \Phi_2}{n_0}, \text{ where } \Phi_1 = \Phi_2 = \Phi'_1$$

= optical power of individual lens and n_0 = R.I. of water.

Now, Φ' = optical power of first convex surface + optical power of second concave surface.

$$= \frac{(n-1)}{R} + \frac{n_0-n}{R}, \text{ } n \text{ is the refractive index of glass.}$$

$$\frac{(2n - n_0 - 1)}{R} \quad (1)$$

and so, the optical power of whole system,

$$\Phi = 2\Phi' - \frac{2d\Phi'^2}{n_0} = 3.0 \text{ D, substituting the values.}$$

5.58 (a) A telescope in normal adjustment is a zero power combination of lenses. Thus we require

$$\Phi = 0 = \Phi_1 + \Phi_2 - \frac{d}{n} \Phi_1 \Phi_2$$

$$\text{But } \Phi_1 = \text{Power of the convex surface} = \frac{n-1}{R_0 + \Delta R}$$

$$\Phi_2 = \text{Power of the concave surface} = -\frac{n-1}{R_0}$$

$$\text{Thus, } 0 = \frac{(n-1)\Delta R}{R_0(R_0 + \Delta R)} + \frac{d}{n} \frac{(n-1)^2}{R_0(R_0 + \Delta R)}$$

$$\text{So } d = \frac{n\Delta R}{n-1} = 4.5 \text{ cm. on putting the values.}$$

$$\begin{aligned} \text{(b) Here, } \Phi = -1 &= \frac{.5}{.1} - \frac{.5}{.075} + \frac{d}{1.5} \times \frac{.5 \times .5}{.1 \times .075} \\ &= 5 - \frac{20}{3} + \frac{d \times 2}{3} \times \frac{5 \times 20}{3} = -\frac{5}{3} + \frac{200d}{9} \\ &= \frac{200d}{9} = \frac{2}{3} \text{ or } d = (3/100) \text{ m} = 3 \text{ cm.} \end{aligned}$$

5.59 (a) The power of the lens is (as in the previous problem)

$$\Phi = \frac{n-1}{R} - \frac{n-1}{R} - \frac{d}{n} \left(\frac{n-1}{R} \right) \left(-\frac{n-1}{R} \right) = \frac{d(n-1)^2}{nR^2} > 0.$$

The principal planes are located on the side of the convex surface at a distance d from each other, with the front principal plane being removed from the convex surface of the lens by a distance $R/(n-1)$.

$$\begin{aligned} \text{(b) Here } \Phi &= -\frac{n-1}{R_1} + \frac{n+1}{R_2} + \frac{R_2 - R_1}{n} \frac{(n-1)^2}{R_1 R_2} \\ &= \frac{(n-1)(R_2 - R_1)}{R_2 R_1} \left[-1 + \frac{n-1}{n} \right] \\ &= -\frac{n-1}{n} \left(\frac{1}{R_1} - \frac{1}{R_2} \right) < 0 \end{aligned}$$

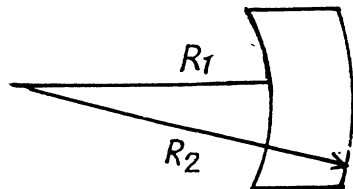

Both principal planes pass through the common centre of curvature of the surfaces of the lens.

5.60 Let the optical powers of the first and second surfaces of the ball of radius R_1 be Φ_1' and Φ_1'' , then

$$\Phi_1' = (n-1)/R_1 \quad \text{and} \quad \Phi_1'' = (1-n)/(-R_1) = \frac{(n-1)}{R_1}$$

This ball may be treated as a thick spherical lens of thickness $2R_1$. So the optical power of this sphere is,

$$\Phi = \Phi_1' - \frac{2R_1 \Phi_1' \Phi_1''}{n} = 2(n-1)/nR_1 \quad (1)$$

Similarly, the optical power of second ball,

$$\Phi_2 = 2(n-1)/nR_2$$

If the distance between the centres of these balls be d . Then the optical power of whole system,

$$\begin{aligned} \Phi &= \Phi_1 + \Phi_2 - d \Phi_1 \Phi_2 \\ &= \frac{2(n-1)}{nR_1} + \frac{2(n-1)}{nR_2} - \frac{4d(n-1)^2}{n^2 R_1 R_2} \\ &= \frac{2(n-1)}{nR_1 R_2} \left[(R_1 + R_2) - \frac{2d(n-1)}{n} \right]. \end{aligned}$$

Now, since this system serves as telescope, the optical power of the system must be equal to zero.

$$(R_1 + R_2) = \frac{2d(n-1)}{n}, \quad \text{as} \quad \frac{2(n-1)}{nR_1 R_2} \neq 0.$$

or,

$$d = \frac{n(R_1 + R_2)}{2(n-1)} = 9 \text{ cm}.$$

Since the diameter D of the objective is $2R_1$ and that of the eye-piece is $d = 2R_2$

So, the magnification,

$$\Gamma = D/d = \frac{2R_1}{2R_2} = R_1 R_2 = 5.$$

5.61 Optical powers of the two surfaces of the lens are

$$\Phi_1 = (n-1)/R \quad \text{and} \quad \Phi_2 = (1-n)/-R = \frac{n-1}{R}$$

So, the power of the lens of thickness d ,

$$\Phi' = \Phi_1 + \Phi_2 - \frac{d\Phi_1\Phi_2}{n} = \frac{n-1}{R} + \frac{n-1}{R} - \frac{d(n-1)^2/R^2}{n^2} = \frac{n^2-1}{nR}$$

and optical power of the combination of these two thick lenses,

$$\Phi = \Phi' + \Phi' = 2\Phi' = \frac{2(n^2-1)}{nR}$$

So, power of this system in air is, $\Phi_0 = \frac{\Phi}{n} = \frac{2(n^2-1)}{n^2R} = 37 \text{ D}$.

5.62 We consider a ray QPR in a medium of gradually varying refractive index n . At P , the gradient of n is a vector with the given direction while is nearly the same at neighbouring points Q, R . The arc length QR is ds . We apply Snell's formula $n \sin \theta = \text{constant}$ where θ is to be measured from the direction ∇n . The refractive indices at Q, R whose mid point is P are

$$\eta \pm \frac{1}{2} |\nabla \eta| d\theta \cos \theta$$

$$\begin{aligned} \text{so} \quad & (\eta - \frac{1}{2} |\nabla n| d\theta \cos \theta) (\sin \theta + \frac{1}{2} \cos \theta d\theta) \\ & = (\eta + \frac{1}{2} |\nabla n| d\theta \cos \theta) (\sin \theta - \frac{1}{2} \cos \theta d\theta) \quad \text{or} \quad n \cos \theta d\theta = |\nabla n| ds \cos \theta \sin \theta \end{aligned}$$

$$\text{(we have used here } \sin(\theta \pm \frac{1}{2} d\theta) = \sin \theta \pm \frac{1}{2} \cos \theta d\theta \text{)}$$

Now using the definition of the radius of curvature $\frac{1}{\rho} = \frac{d\theta}{ds}$

$$\frac{1}{\rho} = \frac{1}{\eta} |\nabla n| \sin \theta$$

The quantity $|\nabla n| \sin \theta$ can be called $\frac{\delta n}{\delta N}$ i.e. the derivative of n along the normal N to

the ray. Then
$$\frac{1}{\rho} = \frac{\delta}{\delta N} \ln n.$$

5.63 From the above problem

$$\frac{1}{\rho} = \frac{1}{n} \hat{p} \cdot \vec{\nabla} n \approx \hat{p} \cdot \nabla n \approx |\nabla n| = 3 \times 10^{-8} \text{ m}^{-1}$$

(since $\hat{p} \parallel \vec{\nabla} n$ both being vertical). So $\rho = 3.3 \times 10^7 \text{ m}$

For the ray of light to propagate all the way round the earth we must have

$$\rho = R = 6400 \text{ km} = 6.4 \times 10^6 \text{ m}$$

$$\text{Thus } |\nabla n| = 1.6 \times 10^{-7} \text{ m}^{-1}$$

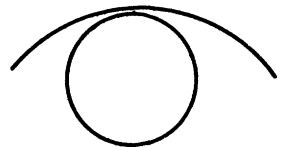

5.2 INTERFERENCE OF LIGHT

5.64 (a) In this case the net vibration is given by

$$x = a_1 \cos \omega t + a_2 \cos (\omega t + \delta)$$

where δ is the phase difference between the two vibrations which varies rapidly and randomly in the interval $(0, 2\pi)$. (This is what is meant by incoherence.)

Then $x = (a_1 + a_2 \cos \delta) \cos \omega t + a_2 \sin \delta \sin \omega t$

The total energy will be taken to be proportional to the time average of the square of the displacement.

$$\text{Thus } E = \langle (a_1 + a_2 \cos \delta)^2 + a_2^2 \sin^2 \delta \rangle = a_1^2 + a_2^2$$

as $\langle \cos \delta \rangle = 0$ and we have put $\langle \cos^2 \omega t \rangle = \langle \sin^2 \omega t \rangle = \frac{1}{2}$ and has been absorbed in the overall constant of proportionality.

In the same units the energies of the two oscillations are a_1^2 and a_2^2 respectively so the proposition is proved.

(b) Here $\vec{r} = a_1 \cos \omega t \hat{i} + a_2 \cos (\omega t + \delta) \hat{j}$

and the mean square displacement is $\propto a_1^2 + a_2^2$

if δ is fixed but arbitrary. Then as in (a) we see that $E = E_1 + E_2$.

5.65 It is easier to do it analytically.

$$\xi_1 = a \cos \omega t, \quad \xi_2 = 2a \sin \omega t$$

$$\xi_3 = \frac{3}{2} a \left(\cos \frac{\pi}{3} \cos \omega t - \sin \frac{\pi}{3} \sin \omega t \right)$$

Resultant vibration is

$$\xi = \frac{7a}{4} \cos \omega t + a \left(2 - \frac{3\sqrt{3}}{4} \right) \sin \omega t$$

This has an amplitude $= \frac{a}{4} \sqrt{49 + (8 - 3\sqrt{3})^2} = 1.89 a$

5.66 We use the method of complex amplitudes. Then the amplitudes are

$$A_1 = a, \quad A_2 = a e^{i\varphi}, \quad \dots \quad A_N = a e^{i(N-1)\varphi}$$

and the resultant complex amplitude is

$$\begin{aligned} A &= A_1 + A_2 + \dots + A_N = a (1 + e^{i\varphi} + e^{2i\varphi} + \dots + e^{i(N-1)\varphi}) \\ &= a \frac{1 - e^{iN\varphi}}{1 - e^{i\varphi}} \end{aligned}$$

The corresponding ordinary amplitude is

$$|A| = a \left| \frac{1 - e^{iN\varphi}}{1 - e^{i\varphi}} \right| = a \left[\frac{1 - e^{iN\varphi}}{1 - e^{i\varphi}} \times \frac{1 - e^{-iN\varphi}}{1 - e^{-i\varphi}} \right]^{1/2}$$

$$= a \left[\frac{2 - 2 \cos N\varphi}{2 - 2 \cos \varphi} \right]^{1/2} = a \frac{\sin \frac{N\varphi}{2}}{\sin \frac{\varphi}{2}}$$

- 5.67 (a) With dipole moment $\perp r$ to plane there is no variation with θ of individual radiation amplitude. Then the intensity variation is due to interference only.

In the direction given by angle θ the phase difference is

$$\frac{2\pi}{\lambda} (d \cos \theta) + \varphi = 2k\pi \quad \text{for maxima}$$

Thus $d \cos \theta = \left(k - \frac{\varphi}{2\pi} \right) \lambda$

$$k = 0, \pm 1, \pm 2, \dots$$

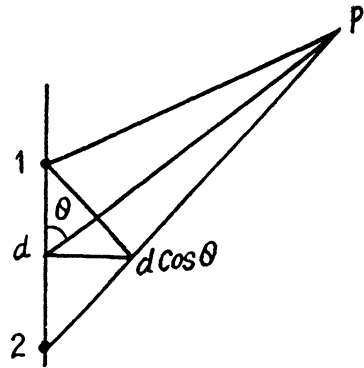

We have added φ to $\frac{2\pi}{\lambda} d \cos \theta$ because the extra path that the wave from 2 has to travel in going to P (as compared to 1) makes it lag more than it already is (due to φ).

- (b) Maximum for $\theta = \pi$ gives $-d = \left(k - \frac{\varphi}{2\pi} \right) \lambda$

Minimum for $\theta = 0$ gives $d = \left(k' - \frac{\varphi}{2\pi} + \frac{1}{2} \right) \lambda$

Adding we get $\left(k + k' - \frac{\varphi}{\pi} + \frac{1}{2} \right) \lambda = 0$

This can be true only if $k' = -k, \varphi = \frac{\pi}{2}$

since $0 < \varphi < \pi$

Then $-d = \left(k - \frac{1}{4} \right) \lambda$

Here $k = 0, -1, -2, -3, \dots$

(Otherwise R.H.S. will become +ve).

Putting $k = -\bar{k}, \bar{k} = 0, +1, +2, +3, \dots$

$$d = \left(\bar{k} + \frac{1}{4} \right) \lambda.$$

5.68 If $\Delta \phi$ is the phase difference between neighbouring radiators then for a maximum in the direction θ we must have

$$\frac{2\pi}{\lambda} d \cos \theta + \Delta \phi = 2\pi k$$

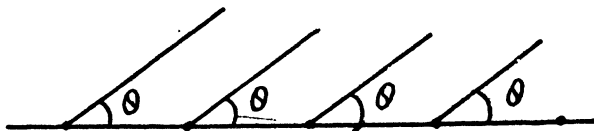

For scanning $\theta = \omega t + \beta$

Thus
$$\frac{d}{\lambda} \cos (\omega t + \beta) + \frac{\Delta \phi}{2\pi} = k$$

or
$$\Delta \phi = 2\pi \left[k - \frac{d}{\lambda} \cos (\omega t + \beta) \right]$$

To get the answer of the book, put $\beta = \alpha - \pi/2$.

5.69 From the general formula

$$\Delta x = \frac{l\lambda}{d}$$

we find that

$$\frac{\Delta x}{\eta} = \frac{l\lambda}{d + 2\Delta h}$$

since d increases to $d + 2\Delta h$ when the source is moved away from the mirror plane by Δh .

Thus $\eta d = d + 2\Delta h$ or $d = 2\Delta h / (\eta - 1)$

Finally
$$\lambda = \frac{2\Delta h \Delta x}{(\eta - 1)l} = 0.6 \mu\text{m}.$$

5.70 We can think of the two coherent plane waves as emitted from two coherent point sources very far away. Then

$$\Delta x = \frac{l\lambda}{d} = \frac{\lambda}{d/l}$$

But

$$\frac{d}{l} = \psi \text{ (if } \psi \ll 1 \text{)}$$

so

$$\Delta x = \frac{\lambda}{\psi}.$$

5.71 (a) Here $S' S'' = d = 2r\alpha$

$$\text{Then } \Delta x = \frac{(b+r)\lambda}{2\alpha}$$

Putting $b = 1.3$ metre, $r = .1$ metre

$$\lambda = 0.55 \mu\text{m}, \alpha = 12' = \frac{1}{5 \times 57} \text{ radian}$$

we get $\Delta x = 1.1$ mm

$$\text{Number of possible maxima} = \frac{2b\alpha}{\Delta x} + 1 = 8.3 + 1 \approx 9$$

($2b\alpha$ is the length of the spot on the screen which gets light after reflection from both mirror. We add 1 above to take account of the fact that in a distance Δx there are two maxima).

- (b) When the slit moves by δl along the arc of radius r the incident ray on the mirror rotates by $\frac{\delta l}{r}$; this is also the rotation of the reflected ray. There is then a shift of the fringe of magnitude.

$$b \frac{\delta l}{r} = 13 \text{ mm.}$$

- (c) If the width of the slit is δ then we can imagine the slit to consist of two narrow slits with separation δ . The fringe pattern due to the wide slit is the superposition of the pattern due to these two narrow slits. The full pattern will not be sharp at all if the pattern due to the two narrow slits are $\frac{1}{2} \Delta x$ apart because then the maxima due to one will fill the minima due to the other. Thus we demand that

$$\frac{b \delta_{\max}}{r} = \frac{1}{2} \Delta x = \frac{(b+r)\lambda}{4r\alpha}$$

or

$$\delta_{\max} = \left(1 + \frac{r}{b}\right) \frac{\lambda}{4\alpha} = 42 \mu\text{m.}$$

5.72 To get this case we must let $r \rightarrow \infty$ in the formula for Δx of the last example.

So

$$\Delta x = \frac{(b+r)\lambda}{2\alpha r} \rightarrow \frac{\lambda}{2\alpha}.$$

(A plane wave is like light emitted from a point source at ∞).

Then

$$\lambda = 2\alpha \Delta x = 0.64 \mu\text{m.}$$

5.73

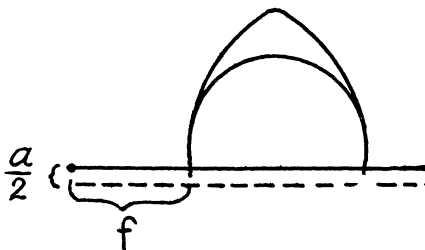

- (a) We show the upper half of the lens. The emergent light is at an angle $\frac{a}{2f}$ from the axis. Thus the divergence angle of the two incident light beams is

$$\psi = \frac{a}{f}$$

When they interfere the fringes produced have a width

$$\Delta x = \frac{\lambda}{\psi} = \frac{f\lambda}{a} = 0.15 \text{ mm.}$$

The patch on the screen illuminated by both light has a width $b\psi$ and this contains

$$\frac{b\psi}{\Delta x} = \frac{b a^2}{f^2 \lambda} \text{ fringes} = 13 \text{ fringes}$$

(if we ignore 1 in comparison on to $\frac{b\psi}{\Delta x}$ (if 5.71 (a))

(b) We follow the logic of (5.71 c). From one edge of the slit to the other edge the distance is of magnitude δ (i.e. $\frac{a}{2}$ to $\frac{a}{2} + \delta$).

If we imagine the edge to shift by this distance, the angle $\psi/2$ will increase by $\frac{\Delta\psi}{2} = \frac{\delta}{2f}$

and the light will shift $\pm b \frac{\delta}{2f}$

The fringe pattern will therefore shift by $\frac{\delta \cdot b}{f}$

Equating this to $\frac{\Delta x}{2} = \frac{f\lambda}{2a}$ we get $\delta_{\max} = \frac{f^2 \lambda}{2ab} = 37.5 \mu \text{ m.}$

5.74 $\Delta x = \frac{l\lambda}{d}$

$$l = a + b$$

$$d = 2(n-1)\theta a$$

$$\delta = (n-1)\theta$$

$$d = 2\delta \cdot a$$

$$n = \text{R.I. of glass}$$

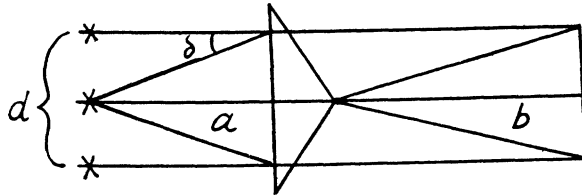

Thus

$$\lambda = \frac{2(n-1)\theta a \Delta x}{a+b} = 0.64 \mu \text{ m.}$$

5.75 It will be assumed that the space between the biprism and the glass plate filled with benzene constitutes complementary prisms as shown.

Then the two prisms being oppositely placed, the net deviation produced by them is

$$\delta = (n-1)\theta - (n'-1)\theta = (n-n')\theta$$

Hence as in the previous problem

$$d = 2a\delta = 2a\theta(n-n')$$

So

$$\Delta x = \frac{(a+b)\lambda}{2a\theta(n-n')}$$

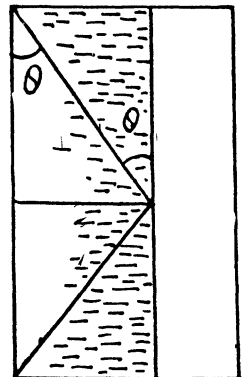

For plane incident wave we let $a \rightarrow \infty$

$$\text{so } \Delta x = \frac{\lambda}{2\theta(n-n')} = 0.2 \text{ mm.}$$

5.76 Extra phase difference introduced by the glass plate is

$$\frac{2\pi}{\lambda}(n-1)h$$

This will cause a shift equal to $(n-1)\frac{h}{\lambda}$ fringe widths

$$\text{i.e. by } (n-1)\frac{h}{\lambda} \times \frac{l\lambda}{d} = \frac{(n-1)hl}{d} = 2 \text{ mm.}$$

The fringes move down if the lower slit is covered by the plate to compensate for the extra phase shift introduced by the plate.

$$\text{5.77 No. of fringes shifted} = (n' - n)\frac{l}{\lambda} = N$$

$$\text{so } n' = n + \frac{N\lambda}{l} = 1.000377.$$

5.78 (a) Suppose the vector \vec{E} , \vec{E}' , \vec{E}'' correspond to the incident, reflected and the transmitted wave. Due to the continuity of the tangential component of the electric field across the interface, it follows that

$$E_{\tau} + E'_{\tau} = E''_{\tau} \quad (1)$$

where the subscript τ means tangential.

The energy flux density is $\vec{E} \times \vec{H} = \vec{S}$.

Since

$$H\sqrt{\mu\mu_0} = E\sqrt{\epsilon\epsilon_0}$$

$$H = E\sqrt{\frac{\epsilon_0}{\mu_0}}\sqrt{\epsilon/\mu} = n\sqrt{\frac{\epsilon_0}{\mu_0}}E$$

Now $S \sim nE^2$ and since the light is incident normally

$$n_1 E_{\tau}^2 = n_1 E_{\tau}'^2 + n_2 E_{\tau}''^2 \quad (2)$$

or

$$n_1 (E_{\tau}^2 - E_{\tau}'^2) = n_2 E_{\tau}''^2$$

so

$$n_1 (E_{\tau} - E_{\tau}') = n_2 E_{\tau}'' \quad (3)$$

so

$$E_{\tau}'' = \frac{2n_1}{n_1 + n_2} E_{\tau}$$

Since E_{τ}'' and E_{τ} have the same sign, there is no phase change involved in this case.

(b) From (1) & (3)

$$(n_2 + n_1)E_{\tau}' + (n_2 - n_1)E_{\tau} = 0$$

or

$$E_{\tau}' = \frac{n_1 - n_2}{n_1 + n_2} E_{\tau}.$$

If $n_2 > n_1$, then E_r' & E_r have opposite signs. Thus the reflected wave has an abrupt change of phase by π if $n_2 > n_1$ i.e. on reflection from the interface between two media when light is incident from the rarer to denser medium.

5.79

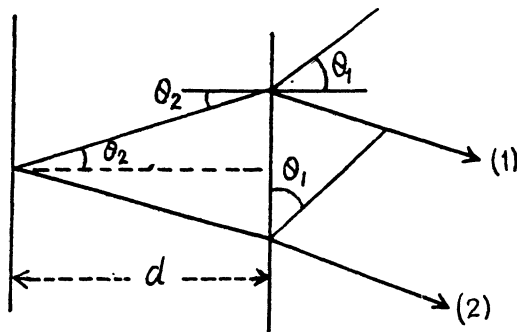

Path difference between (1) & (2) is

$$2 n d \sec \theta_2 - 2 d \tan \theta_2 \sin \theta_1$$

$$= 2 d \frac{n - \frac{\sin^2 \theta_1}{n}}{\sqrt{1 - \frac{\sin^2 \theta_1}{n^2}}} = 2 d \sqrt{n^2 - \sin^2 \theta_1}$$

For bright fringes this must equal $\left(k + \frac{1}{2}\right) \lambda$ where $\frac{1}{2}$ comes from the phase change of π for (1).

Here

$$k = 0, 1, 2, \dots$$

Thus

$$4 d \sqrt{n^2 - \sin^2 \theta_1} = (2k + 1) \lambda$$

or

$$d = \frac{\lambda(1 + 2k)}{4 \sqrt{n^2 - \sin^2 \theta_1}} = 0.14(1 + 2k) \mu \text{ m} \dots$$

5.80 Given

$$2 d \sqrt{n^2 - 1/4} = \left(k + \frac{1}{2}\right) \times 0.64 \mu \text{ m} \quad (\text{bright fringe})$$

$$2 d \sqrt{n^2 - 1/4} = k' \times 0.40 \mu \text{ m} \quad (\text{dark fringe})$$

where k, k' are integers.

$$\text{Thus} \quad 64 \left(k + \frac{1}{2}\right) = 40 k' \quad \text{or} \quad 4(2k + 1) = 5k'$$

This means, for the smallest integer solutions

$$k = 2, k' = 4$$

Hence

$$d = \frac{4 \times 0.40}{2 \sqrt{n^2 - 1/4}} = 0.65 \mu \text{ m} \dots$$

5.81 When the glass surface is coated with a material of R.I. $n' = \sqrt{n}$ ($n =$ R.I. of glass) of appropriate thickness, reflection is zero because of interference between various multiply reflected waves. We show this below.

Let a wave of unit amplitude be normally incident from the left. The reflected amplitude is $-r$ where

$$r = \frac{\sqrt{n} - 1}{\sqrt{n} + 1}$$

Its phase is $-ve$ so we write the reflected wave as $-r$. The transmitted wave has amplitude t

$$t = \frac{2}{1 + \sqrt{n}}$$

This wave is reflected at the second face and has amplitude $-tr$

$$\left(\text{because } \frac{n - \sqrt{n}}{n + \sqrt{n}} = \frac{\sqrt{n} - 1}{\sqrt{n} + 1} \right)$$

The emergent wave has amplitude $-tr'$.

We prove below that $-tr' = 1 - r^2$. There is also a reflected part of amplitude $trr' = -tr^2$, where r' is the reflection coefficient for a ray incident from the coating towards air. After reflection from the second face a wave of amplitude

$$+tr'r^3 = +(1 - r^2)r^3$$

emerges. Let δ be the phase of the wave after traversing the coating both ways.

Then the complete reflected wave is

$$\begin{aligned} & -r - (1 - r^2)r e^{i\delta} + (1 - r^2)r^3 e^{2i\delta} \\ & \quad - (1 - r^2)r^5 e^{3i\delta} \dots \dots \\ & = -r - (1 - r^2)r e^{i\delta} \frac{1}{1 + r^2 e^{i\delta}} \\ & = -r \left[1 + r^2 e^{i\delta} + (1 - r^2) e^{i\delta} \right] \frac{1}{1 + r^2 e^{i\delta}} \\ & = -r \frac{1 + e^{i\delta}}{1 + r^2 e^{i\delta}} \end{aligned}$$

This vanishes if $\delta = (2k + 1)\pi$. But

$$\delta = \frac{2\pi}{\lambda} 2\sqrt{n} d \text{ so}$$

$$d = \frac{\lambda}{4\sqrt{n}} (2k + 1)$$

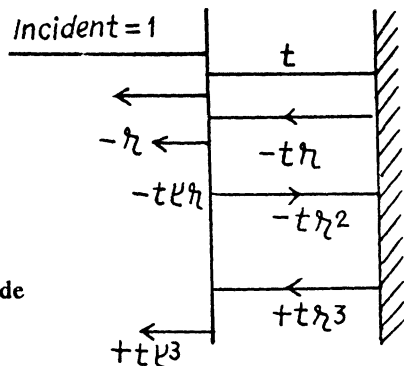

We now deduce $tt' = 1 - r^2$ and $r' = +r$. This follows from the principle of reversibility of light path as shown in the figure below.

$$\begin{aligned} tt' + r^2 &= 1 \\ -rt + r't &= 0 \\ \therefore tt' &= 1 - r^2 \\ r' &= +r. \end{aligned}$$

($-r$ is the reflection ratio for the wave entering a denser medium).

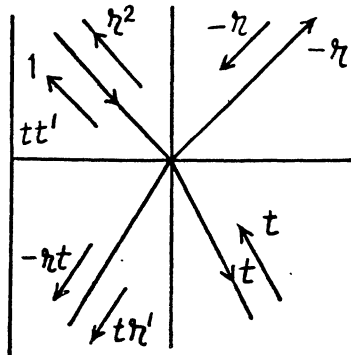

5.82 We have the condition for maxima

$$2d\sqrt{n^2 - \sin^2 \theta_1} = \left(k + \frac{1}{2}\right)\lambda$$

This must hold for angle $\theta \pm \frac{\delta \theta}{2}$ with successive values of k . Thus

$$2d\sqrt{n^2 - \sin^2 \left(\theta + \frac{\delta \theta}{2}\right)} = \left(k - \frac{1}{2}\right)\lambda$$

$$2d\sqrt{n^2 - \sin^2 \left(\theta - \frac{\delta \theta}{2}\right)} = \left(k + \frac{1}{2}\right)\lambda$$

Thus

$$\begin{aligned} \lambda &= 2d \left\{ \sqrt{n^2 - \sin^2 \theta + \delta \theta \sin \theta \cos \theta} \right. \\ &\quad \left. - \sqrt{n^2 - \sin^2 \theta - \delta \theta \sin \theta \cos \theta} \right\} \\ &= 2d \frac{\delta \theta \sin \theta \cos \theta}{\sqrt{n^2 - \sin^2 \theta}} \end{aligned}$$

Thus

$$d = \frac{\sqrt{n^2 - \sin^2 \theta} \lambda}{\sin 2\theta \delta \theta} = 15.2 \mu\text{m}$$

5.83 For small angles θ we write for dark fringes

$$2d\sqrt{n^2 - \sin^2 \theta} = 2d\left(n - \frac{\sin^2 \theta}{2n}\right) = (k+0)\lambda$$

For the first dark fringe $\theta = 0$ and

$$2dn = (k_0 + 0)\lambda$$

For the i^{th} dark fringe

$$2d\left(n - \frac{\sin^2 \theta_i}{2n}\right) = (k_0 - i + 1)\lambda$$

or

$$\sin^2 \theta_i = \frac{n\lambda}{d} (i - 1) = \frac{r_i^2}{4l^2}$$

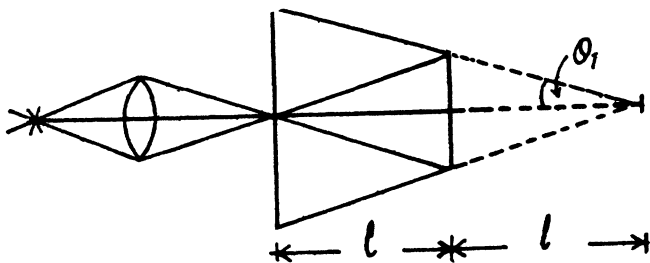

Finally

$$\frac{n\lambda}{d}(i-k) = \frac{r_i^2 - r_k^2}{4l^2}$$

so

$$\lambda = \frac{d(r_i^2 - r_k^2)}{4l^2 n(i-k)}$$

5.84 We have the usual equation for maxima

$$2h_k \alpha \sqrt{n^2 - \sin^2 \theta_1} = \left(k + \frac{1}{2}\right) \lambda$$

Here h_k = distance of the fringe from top

$h_k \alpha = d_k$ = thickness of the film

Thus on the screen placed at right angles to the reflected light

$$\begin{aligned} \Delta x &= (h_k - h_{k-1}) \cos \theta_1 \\ &= \frac{\lambda \cos \theta_1}{2\alpha \sqrt{n^2 - \sin^2 \theta_1}} \end{aligned}$$

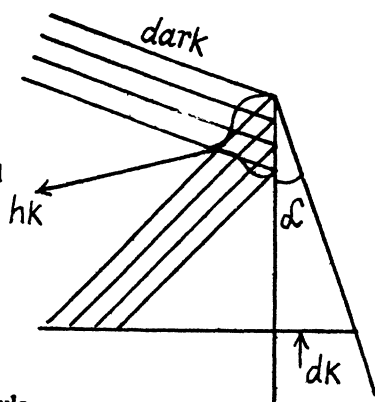

5.85 (a) For normal incidence we have using the above formula

$$\Delta x = \frac{\lambda}{2n\alpha}$$

so

$$\alpha = \frac{\lambda}{2n\Delta x} = 3' \text{ on putting the values}$$

(b) In a distance l on the wedge there are $N = \frac{l}{\Delta x}$ fringes.

If the fringes disappear there, it must be due to the fact that the maxima due to the component of wavelength λ coincide with the minima due to the component of wavelength $\lambda + \Delta\lambda$. Thus

$$N\lambda = \left(N - \frac{1}{2}\right)(\lambda + \Delta\lambda) \text{ or } \Delta\lambda = \frac{\lambda}{2N}$$

so

$$\frac{\Delta\lambda}{\lambda} = \frac{1}{2N} = \frac{\Delta x}{2l} = \frac{0.21}{30} = 0.007.$$

The answer given in the book is off by a factor 2.

5.86 We have

$$r^2 = \frac{1}{2} k \lambda R$$

So for k differing by 1 ($\Delta k = 1$)

$$2r \Delta r = \frac{1}{2} \Delta k \lambda R = \frac{1}{2} \lambda R$$

or
$$\Delta r = \frac{\lambda R}{4r}.$$

5.87 The path traversed in air film of the wave constituting the k^{th} ring is

$$\frac{r^2}{R} = \frac{1}{2} k \lambda$$

when the lens is moved a distance Δh the ring radius changes to r' and the path length becomes

$$\frac{r'^2}{R} + 2 \Delta h = \frac{1}{2} k \lambda$$

Thus

$$r' = \sqrt{r^2 - 2R \Delta h} = 1.5 \text{ mm}.$$

5.88 In this case the path difference is $\frac{r^2 - r_0^2}{R}$ for $r > r_0$ and zero for $r \leq r_0$.

This must equal $(k - 1/2) \lambda$ (where $k = 6$ for the sixth bright ring.)

$$\text{Thus } r = \sqrt{r_0^2 + \left(k - \frac{1}{2}\right) \lambda R} = 3.8 \text{ mm}$$

5.89 From the formula for Newton's rings we derive for dark rings

$$\frac{d_1^2}{4} = k_1 R \lambda, \quad \frac{d_2^2}{4} = k_2 R \lambda$$

so
$$\frac{d_2^2 - d_1^2}{4(k_2 - k_1)R} = \lambda$$

Substituting the values, $\lambda = 0.5 \mu\text{m}$.

5.90 Path difference between waves reflected by the two convex surfaces is

$$r^2 \left(\frac{1}{R_1} + \frac{1}{R_2} \right)$$

Taking account of the phase change at the 2nd surface we write the condition of bright rings as

$$r^2 \left(\frac{1}{R_1} + \frac{1}{R_2} \right) = \frac{2k+1}{2} \lambda$$

$k = 4$ for the fifth bright ring.

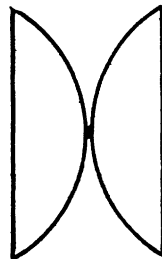

Thus
$$\frac{1}{R_1} + \frac{1}{R_2} = \frac{9}{2} \lambda \cdot \frac{4}{d^2} = \frac{18 \lambda}{d^2}$$

Now
$$\frac{1}{f_1} = (n-1) \frac{1}{R_1}, \quad \frac{1}{f_2} = (n-1) \frac{1}{R_2}$$

so
$$\frac{1}{f} = \frac{1}{f_1} + \frac{1}{f_2} = (n-1) \frac{18 \lambda}{d^2} = \Phi = 2.40 \text{ D}$$

Here $n = \text{R.I. of glass} = 1.5$.

5.91 Here $\Phi = (n-1) \left(\frac{2}{R_1} - \frac{2}{R_2} \right)$

so
$$\frac{1}{R_1} - \frac{1}{R_2} = \frac{\Phi}{2(n-1)}$$

As in the previous example, for the dark rings we have

$$r_k^2 \left(\frac{1}{R_1} - \frac{1}{R_2} \right) = \frac{\Phi}{2(n-1)} r_k^2 = k \lambda$$

$k = 0$ is dark spot; excluding it, we take $k = 10$ here.

Then
$$r = \sqrt{\frac{20 \lambda (n-1)}{\Phi}} = 3.49 \text{ mm.}$$

(b) Path difference in water film will be

$$n_0 \bar{r}^2 \left(\frac{1}{R_1} - \frac{1}{R_2} \right)$$

where \bar{r} = new radius of the ring. Thus

$$n_0 \bar{r}^2 = r^2$$

or

$$\bar{r} = r / \sqrt{n_0} = 3.03 \text{ mm.}$$

Where $n_0 = \text{R.I. of water} = 1.33$.

5.92 The condition for minima are

$$\frac{r^2}{R} n_2 = \left(k + \frac{1}{2} \right) \lambda,$$

(There occur phase changes at both surfaces on reflection, hence minima when path difference is half integer multiple of λ).

In this case $k = 4$ for the fifth dark ring

(Counting from $k = 0$ for the first dark ring).

Thus, we can write

$$r = \sqrt{(2K-1) \lambda R / 2 n_2}, \quad K = 5$$

Substituting we get $r = 1.17 \text{ mm.}$

5.93 Sharpness of the fringe pattern is the worst when the maxima and minima intermingle :-

$$n_1 \lambda_1 = \left(n_1 - \frac{1}{2} \right) \lambda_2$$

or putting

$$\lambda_1 = \lambda, \lambda_2 = \lambda + \Delta \lambda$$

we get

$$n_1 \Delta \lambda = \frac{\lambda}{2}$$

or

$$n_1 = \frac{\lambda}{2 \Delta \lambda} = \frac{\lambda_1}{2(\lambda_2 - \lambda_1)} = 140.$$

5.94 Interference pattern vanishes when the maxima due to one wavelength mingle with the minima due to the other. Thus

$$2 \Delta h = k \lambda_2 = (k+1) \lambda_1$$

where Δh = displacement of the mirror between the sharpest patterns of rings

Thus

$$k(\lambda_2 - \lambda_1) = \lambda_1$$

or

$$k = \frac{\lambda_1}{\lambda_2 - \lambda_1}$$

So

$$\Delta h = \frac{\lambda_1 \lambda_2}{2(\lambda_2 - \lambda_1)} = \frac{\lambda^2}{2 \Delta \lambda} = .29 \text{ mm}.$$

5.95 The path difference between (1) & (2) can be seen to be

$$\begin{aligned} \Delta &= 2d \sec \theta - 2d \tan \theta \sin \theta \\ &= 2d \cos \theta = k \lambda \end{aligned}$$

for maxima. Here k = half-integer.

The order of interference decreases as θ increases i.e. as the radius of the rings increases.

(b) Differentiating

$$2d \sin \theta \delta \theta = \lambda$$

on putting $\delta k = -1$. Thus

$$\delta \theta = \frac{\lambda}{2d \sin \theta}$$

$\delta \theta$ decreases as θ increases.

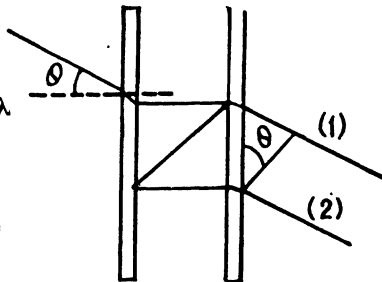

5.96 (a) We have $k_{\max} = \frac{2d}{\lambda}$ for $\theta = 0 = 10^5$.

(b) We must have

$$2d \cos \theta = k \lambda = (k-1)(\lambda + \Delta \lambda)$$

Thus $\frac{1}{k} = \frac{\lambda}{2d}$ and $\Delta \lambda = \frac{\lambda}{k} = \frac{\lambda^2}{2d} = 5 \text{ pm}$. on putting the values.

5.3 DIFFRACTION OF LIGHT

5.97 The radius of the periphery of the N^{th} Fresnel zone is

$$r_N = \sqrt{N b \lambda}$$

Then by conservation of energy

$$I_0 \pi (\sqrt{N b \lambda})^2 = \int_0^{\infty} 2 \pi r dr I(r)$$

Here r is the distance from the point P .

Thus

$$I_0 = \frac{2}{N b \lambda} \int_0^{\infty} r dr I(r).$$

5.98 By definition

$$r_k^2 = k \frac{a b \lambda}{a + b}$$

for the periphery of the k^{th} zone. Then

$$a r_k^2 + b r_k^2 = k a b \lambda$$

So

$$b = \frac{a r_k^2}{k a \lambda - r_k^2} = \frac{a r^2}{k a \lambda - r^2} = 2 \text{ metre.}$$

on putting the values. (It is given that $r = r_k$ for $k = 3$).

5.99 Suppose maximum intensity is obtained when the aperture contains k zones. Then a minimum will be obtained for $k + 1$ zones. Another maximum will be obtained for $k + 2$ zones. Hence

$$r_1^2 = k \lambda \frac{a b}{a + b}$$

$$r_2^2 = (k + 2) \lambda \frac{a b}{a + b}$$

Thus

$$\lambda = \frac{a + b}{2 a b} (r_2^2 - r_1^2) = 0.598 \mu \text{m}$$

On putting the values.

5.100 (a) When the aperture is equal to the first Fresnel Zone :-

The amplitude is A_1 and should be compared with the amplitude $\frac{A}{2}$ when the aperture is very wide. If I_0 is the intensity in the second case the intensity in the first case will be $4 I_0$.

When the aperture is equal to the internal half of the first zone :- Suppose A_{in} and A_{out} are the amplitudes due to the two halves of the first Fresnel zone. Clearly A_{in} and A_{out}

differ in phase by $\frac{\pi}{2}$ because only half the Fresnel zone is involved. Also in magnitude

$|A_{in}| = |A_{out}|$. Then

$$A_1^2 = 2 |A_{in}|^2 \quad \text{so} \quad |A_{in}|^2 = \frac{A_1^2}{2}$$

Hence following the argument of the first case. $I_{in} = 2 I_0$

- (b) The aperture was made equal to the first Fresnel zone and then half of it was closed along a diameter. In this case the amplitude of vibration is $\frac{A_1}{2}$. Thus

$$I = I_0.$$

- 5.101 (a) Suppose the disc does not obstruct light at all. Then

$$A_{disc} + A_{remainder} = \frac{1}{2} A_{disc}$$

(because the disc covers the first Fresnel zone only).

$$\text{So } A_{remainder} = -\frac{1}{2} A_{disc}$$

Hence the amplitude when half of the disc is removed along a diameter

$$= \frac{1}{2} A_{disc} + A_{remainder} = \frac{1}{2} A_{disc} - \frac{1}{2} A_{disc} = 0$$

Hence $I = 0$.

- (b) In this case

$$\begin{aligned} A &= \frac{1}{2} A_{external} + A_{remainder} \\ &= \frac{1}{2} A_{external} - \frac{1}{2} A_{disc} \end{aligned}$$

We write

$$A_{disc} = A_{in} + i A_{out}$$

where A_{in} (A_{out}) stands for $A_{internal}$ ($A_{external}$). The factor i takes account of the $\frac{\pi}{2}$ phase difference between two halves of the first Fresnel zone. Thus

$$A = -\frac{1}{2} A_{in} \quad \text{and} \quad I = \frac{1}{4} A_{in}^2$$

On the other hand

$$I_0 = \frac{1}{4} (A_{in}^2 + A_{out}^2) = \frac{1}{2} A_{in}^2$$

so

$$I = \frac{1}{2} I_0.$$

- 5.102 When the screen is fully transparent, the amplitude of vibrations is $\frac{1}{2} A_1$ (with intensity

$$I_0 = \frac{1}{4} A_1^2).$$

- (a) (1) In this case $A = \frac{3}{4} \left(\frac{1}{2} A_1 \right)$ so squaring $I = \frac{9}{16} I_0$

(2) In this case $\frac{1}{2}$ of the plane is blocked out so

$$A = \frac{1}{2} \left(\frac{1}{2} A_1 \right) \quad \text{and} \quad I = \frac{1}{4} I_0$$

(3) In this case $A = \frac{1}{4} (A_1 / 2)$ and $I = \frac{1}{16} I_0$.

(4) In this case $A = \frac{1}{2} \left(\frac{1}{2} A_1 \right)$ again and $I = \frac{1}{4} I_0$ so $I_4 = \frac{I}{2}$

In general we get $I(\varphi) = I_0 \left(1 - \left(\frac{\varphi}{2\pi} \right) \right)^2$

where φ is the total angle blocked out by the screen.

(b) (5) Here $A = \frac{3}{4} \left(\frac{1}{2} A_1 \right) + \frac{1}{4} A_1$

A_1 being the contribution of the first Fresnel zone.

Thus $A = \frac{5}{8} A_1$ and $I = \frac{25}{16} I_0$

(6) $A = \frac{1}{2} \left(\frac{1}{2} A_1 \right) + \frac{1}{2} A_1 = \frac{3}{4} A_1$ and $I = \frac{9}{4} I_0$

(7) $A = \frac{1}{4} \left(\frac{1}{2} A_1 \right) + \frac{3}{4} A_1 = \frac{7}{8} A_1$ and $I = \frac{49}{16} I_0$

(8) $A = \frac{1}{2} \left(\frac{1}{2} A_1 \right) + \frac{1}{2} A_1 = \frac{3}{4} A_1$ and $I = \frac{9}{4} I_0$ ($I_8 = I_6$)

In 5 to 8 the first term in the expression for the amplitude is the contribution of the plane part and the second term gives the expression for the Fresnel zone part. In general in (5) to

(8) $I = I_0 \left(1 + \left(\frac{\varphi}{2\pi} \right) \right)^2$ when φ is the angle covered by the screen.

5.103 We would require the contribution to the amplitude of a wave at a point from half a Fresnel zone. For this we proceed directly from the Fresnel Huyghens principle. The complex amplitude is written as

$$E = \int K(\varphi) \frac{a_0}{r} e^{-ikr} dS$$

Here $K(\varphi)$ is a factor which depends on the angle φ between a normal \vec{n} to the area dS and the direction from dS to the point P and r is the distance from the element dS to P .

We see that for the first Fresnel zone

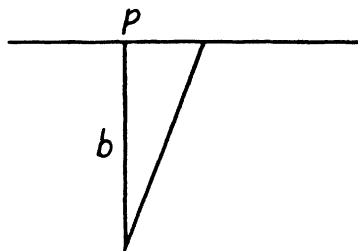

$$E = \frac{a_0}{b} \int_0^{\sqrt{b\lambda}} e^{-ikb - ik\rho^2/2b} 2\pi\rho d\rho \quad (K(\varphi) = 1)$$

(using $r = b + \frac{\rho^2}{2b}$ (for $\sqrt{\rho^2 + b^2}$))

For the first Fresnel zone $r = b + \lambda/2$ so $r^2 = b^2 + b\lambda$ and $\rho^2 = b\lambda$.

Thus

$$\begin{aligned} E &= \frac{a_0}{b} e^{-ikb} 2\pi \int_0^{\frac{b\lambda}{2}} e^{-i\frac{kx}{b}} dx \\ &= \frac{a_0}{b} 2\pi e^{-ikb} \frac{e^{-ik\lambda/2} - 1}{-ik/b} \\ &= \frac{a_0}{k} 2\pi i e^{-ikb} (-2) = -\frac{4\pi}{k} i a_0 e^{-ikb} = A_1 \end{aligned}$$

For the next half zone

$$\begin{aligned} E &= \frac{a_0}{b} e^{-ikb} 2\pi \int_{\frac{b\lambda}{2}}^{\frac{3b\lambda}{4}} e^{-ikx/b} dx \\ &= \frac{a_0}{k} 2\pi i e^{-ikb} \left(e^{-i\frac{3k\lambda}{4}} - e^{-ik\lambda/2} \right) \\ &= \frac{a_0}{k} 2\pi i e^{-ikb} (+1+i) = -\frac{A_1(1+i)}{2} \end{aligned}$$

If we calculate the contribution of the full 2nd Fresnel zone we will get $-A_1$. If we take account of the factors $K(\varphi)$ and $\frac{1}{r}$ which decrease monotonically we expect the contribution to change to $-A_2$. Thus we write for the contribution of the half zones in the 2nd Fresnel zone as

$$-\frac{A_2(1+i)}{2} \quad \text{and} \quad -\frac{A_2(1-i)}{2}$$

The part lying in the recess has an extra phase difference equal to $-\delta = -\frac{2\pi}{\lambda}(n-1)h$. Thus the full amplitude is (note that the correct form is e^{-ikr})

$$\begin{aligned} &\left(A_1 - \frac{A_2}{2}(1+i) \right) e^{+i\delta} - \frac{A_2}{2}(1-i) + A_3 - A_4 + \dots \\ &= \left(\frac{A_1}{2}(1-i) \right) e^{+i\delta} - \frac{A_2}{2}(1-i) + \frac{A_3}{2} \end{aligned}$$

$$= \left(\frac{A_1}{2} (1-i) \right) e^{+i\delta} + i \frac{A_1}{2} \quad (\text{as } A_2 = A_3 = A_1) \text{ and } A_3 - A_4 + A_5 \dots = \frac{A_3}{2}.$$

The corresponding intensity is

$$\begin{aligned} I &= \frac{A_1^2}{4} \left[(1-i) e^{+i\delta} + \frac{i}{e} \right] \left[(1+i) e^{-i\delta} - i \right] \\ &= I_0 [3 - 2 \cos \delta + 2 \sin \delta] = I_0 \left[3 + 2\sqrt{2} \sin \left(\delta - \frac{\pi}{4} \right) \right] \end{aligned}$$

(a) For maximum intensity $\sin \left(\delta - \frac{\pi}{4} \right) = +1$

or $\delta - \frac{\pi}{4} = 2k\pi + \frac{\pi}{2}, k = 0, 1, 2, \dots$

$$\delta = 2k\pi + \frac{3\pi}{4} = \frac{2\pi}{\lambda} (n-1)h$$

so
$$h = \frac{\lambda}{n-1} \left(k + \frac{3}{8} \right)$$

(b) For minimum intensity

$$\sin \left(\delta - \frac{\pi}{4} \right) = -1$$

$$\delta - \frac{\pi}{4} = 2k\pi + \frac{3\pi}{2} \quad \text{or} \quad \delta = 2k\pi + \frac{7\pi}{4}$$

so
$$h = \frac{\lambda}{n-1} \left(k + \frac{7\pi}{8} \right)$$

(c) For $I = I_0, \cos \delta = 0$ } or $\left\{ \begin{array}{l} \sin \delta = 0 \\ \sin \delta = -1 \end{array} \right.$

Thus
$$\delta = 2k\pi \quad h = \frac{k\lambda}{n-1}$$

or
$$\delta = 2k\pi + \frac{3\pi}{2}, \quad h = \frac{\lambda}{n-1} \left(k + \frac{3\pi}{4} \right)$$

5.104 The contribution to the wave amplitude of the inner half-zone is

$$\begin{aligned} & \frac{2\pi a_0 e^{-ikb}}{b} \int_0^{\sqrt{b\lambda/2}} e^{-ik\rho^2/2b} \rho d\rho \\ &= \frac{2\pi a_0 e^{-ikb}}{b} \int_0^{b\lambda/4} e^{-ikx/b} dx \\ &= \frac{2\pi a_0 e^{-ikb}}{b} (e^{-ik\lambda/4} - 1) \times \frac{1}{-ik} \end{aligned}$$

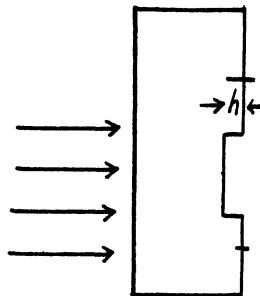

$$= \frac{2\pi i a_0 e^{-ikb}}{k} (-i-1) = +\frac{A_1}{2}(1+i)$$

With phase factor this becomes $\frac{A_1}{2}(1+i)e^{i\delta}$ where $\delta = \frac{2\pi}{\lambda}(n-1)h$. The contribution of the remaining aperture is $\frac{A_1}{2}(1-i)$

(so that the sum of the two parts when $\delta = 0$ is A_1)

Thus the complete amplitude is

$$\frac{A_1}{2}(1+i)e^{i\delta} + \frac{A_1}{2}(1-i)$$

and the intensity is

$$\begin{aligned} I &= I_0 [(1+i)e^{i\delta} + (1-i)] [(1-i)e^{-i\delta} + (1+i)] \\ &= I_0 [2 + 2 + (1-i)^2 e^{-i\delta} + (1+i)^2 e^{i\delta}] \\ &= I_0 [4 - 2ie^{-i\delta} + 2ie^{i\delta}] = I_0 (4 - 4 \sin \delta) \end{aligned}$$

Here $I_0 = \frac{A_1^2}{4}$ is the intensity of the incident light which is the same as the intensity due to an aperture of infinite extent (and no recess). Now

I is maximum when $\sin \delta = -1$

$$\text{or} \quad \delta = 2k\pi + \frac{3\pi}{2}$$

$$\text{so} \quad h = \frac{\lambda}{n-1} \left(k + \frac{3}{4} \right) \quad \text{and (b)} \quad I_{\max} = 8I_0.$$

5.105 We follow the argument of 5.103. we find that the contribution of the first Fresnel zone is

$$A_1 = -\frac{4\pi i}{k} a_0 e^{-ikb}$$

For the next half zone it is $-\frac{A_2}{2}(1+i)$

(The contribution of the remaining part of the 2nd Fresnel zone will be $-\frac{A_2}{2}(1-i)$)

If the disc has a thickness h , the extra phase difference suffered by the light wave in passing through the disc will be

$$\delta = \frac{2\pi}{\lambda} (n-1)h.$$

Thus the amplitude at P will be

$$\begin{aligned} E_P &= \left(A_1 - \frac{A_2}{2}(1+i) \right) e^{-i\delta} - \frac{A_2}{2}(1-i) + A_3 - A_4 - A_5 + \dots \\ &= \left(\frac{A_1(1-i)}{2} \right) e^{-i\delta} + \frac{iA_1}{2} = \frac{A_1}{2} [(1-i)e^{-i\delta} + i] \end{aligned}$$

The corresponding intensity will be

$$I = I_0 (3 - 2 \cos \delta - 2 \sin \delta) = I_0 \left(3 - 2\sqrt{2} \sin \left(\delta + \frac{\pi}{4} \right) \right)$$

The intensity will be a maximum when

$$\sin \left(\delta + \frac{\pi}{4} \right) = -1$$

or
$$\delta + \frac{\pi}{4} = 2k\pi + \frac{3\pi}{2}$$

i.e.
$$\delta = \left(k + \frac{5}{8} \right) \cdot 2\pi$$

so
$$h = \frac{\lambda}{n-1} \left(k + \frac{5}{8} \right), k = 0, 1, 2, \dots$$

Note :- It is not clear why $k = 2$ for h_{\min} . The normal choice will be $k = 0$. If we take $k = 0$ we get $h_{\min} = 0.59 \mu\text{m}$.

5.106 Here the focal point acts as a virtual source of light. This means that we can take spherical waves converging towards F . Let us divide these waves into Fresnel zones just after they emerge from the stop.

$$r^2 = f^2 - (f-h)^2 = (b-m\lambda/2)^2 - (b-h)^2$$

Here r is the radius of the m^{th} fresnel zone and h is the distance to the left of the foot of the perpendicular. Thus

$$r^2 = 2fh = -bm\lambda + 2bh$$

So
$$h = bm\lambda/2(b-f)$$

and
$$r^2 = fbm\lambda/(b-f).$$

The intensity maxima are observed when an odd number of Fresnel zones are exposed by the stop. Thus

$$r_k = \sqrt{\frac{kbf\lambda}{b-f}} \quad \text{where } k = 1, 3, 5, \dots$$

5.107 For the radius of the periphery of the k^{th} zone we have

$$r_k = \sqrt{k\lambda \frac{ab}{a+b}} = \sqrt{k\lambda b} \quad \text{if } a = \infty.$$

If the aperture diameter is reduced η times it will produce a similar diffraction pattern (reduced η times) if the radii of the Fresnel zones are also η times less. Thus

$$r'_k = r_k/\eta$$

$$\text{This requires } b' = b/\eta^2.$$

5.108 (a) If a point source is placed before an opaque ball, the diffraction pattern consists of a bright spot inside a dark disc followed by fringes. The bright spot is on the line joining the point source and the centre of the ball. When the object is a finite source of transverse

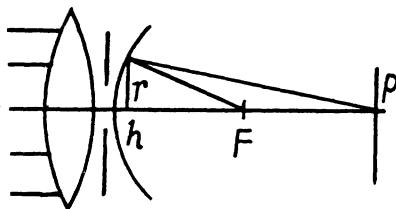

dimension y , every point of the source has its corresponding image on the line joining that point and the centre of the ball. Thus the transverse dimension of the image is given by

$$y' = \frac{b}{a} y = 9 \text{ mm.}$$

- (b) The minimum height of the irregularities covering the surface of the ball at random, at which the ball obstructs light is, according to the note at the end of the problem, comparable with the width of the Fresnel zone along which the edge of opaque screen passes.

So
$$h_{\min} = \Delta r$$

To find Δr we note that

$$r^2 = \frac{k\lambda ab}{a+b}$$

or
$$2r\Delta r = D\Delta r = \frac{\lambda ab}{a+b} \Delta k$$

Where D = diameter of the disc (= diameter of the last Fresnel zone) and $\Delta k = 1$

Thus
$$h_{\min} = \frac{\lambda ab}{D(a+b)} = 0.099 \text{ mm.}$$

- 5.109** In a zone plate an undarkened circular disc is followed by a number of alternately undarkened and darkened rings. For the proper case, these correspond to 1st, 2nd, 3rd..... Fresnel zones.

Let r_1 = radius of the central undarkened circle. Then for this to be first Fresnel zone in the present case, we must have

$$SL + LI - SI = \lambda/2$$

Thus if r_1 is the radius of the periphery of the first zone

$$\sqrt{a^2 + r_1^2} + \sqrt{b^2 + r_1^2} - (a+b) = \frac{\lambda}{2}$$

or
$$\frac{r_1^2}{2} \left(\frac{1}{a} + \frac{1}{b} \right) = \frac{\lambda}{2} \quad \text{or} \quad \frac{1}{a} + \frac{1}{b} = \frac{1}{r_1^2/\lambda}$$

It is clear that the plate is acting as a lens of focal length

$$f_1 = \frac{r_1^2}{\lambda} = \frac{ab}{a+b} = .6 \text{ metre.}$$

This is the principle focal length.

Other maxima are obtained when

$$SL + LI - SI = 3\frac{\lambda}{2}, 5\frac{\lambda}{2}, \dots$$

These focal lengths are also
$$\frac{r_1^2}{3\lambda}, \frac{r_1^2}{5\lambda}, \dots$$

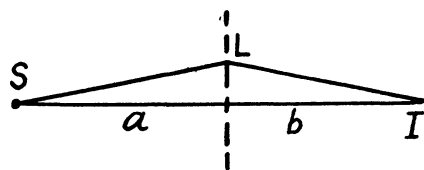

5.110 Just below the edge the amplitude of the wave is given by

$$A = \frac{1}{2}(A_1 - A_2 + A_3 - A_4 + \dots) e^{-i\delta}$$

$$+ \frac{1}{2}(A_1 - A_2 + A_3 - A_4 + \dots)$$

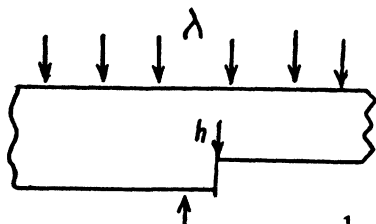

Here the quantity in the brackets is the contribution of various Fresnel zones; the factor $\frac{1}{2}$ is to take account of the division of the plate into two parts by the ledge; the phase factor δ is given by

$$\delta = \frac{2\pi}{\lambda} h(n-1)$$

and takes into account the extra length traversed by the waves on the left.

Using
$$A_1 - A_2 + A_3 - A_4 + \dots \approx \frac{A_1}{2}$$

we get
$$A = \frac{A_1}{4}(1 + e^{i\delta})$$

and the corresponding intensity is

$$I = I_0 \frac{1 + \cos \delta}{2}, \quad \text{where } I_0 \propto \left(\frac{A_1}{2}\right)^2$$

(a) This is minimum when

$$\cos \delta = -1$$

So

$$\delta = (2k+1)\pi$$

and

$$h = (2k+1) \frac{\lambda}{2(n-1)}, \quad k = 0, 1, 2, \dots$$

using $n = 1.5$, $\lambda = 0.60 \mu m$

$$h = 0.60(2k+1) \mu m.$$

(b) $I = I_0/2$ when $\cos \delta = 0$

or

$$\delta = k\pi + \frac{\pi}{2} = (2k+1) \frac{\pi}{2}$$

Thus in this case

$$h = 0.30(2k+1) \mu m.$$

5.111 (a) From the Cornu's spiral, the intensity of the first maximum is given as

$$I_{\max,1} = 1.37 I_0$$

and the intensity of the first minimum is given by

$$I_{\min} = 0.78 I_0$$

so the required ratio is

$$\frac{I_{\max}}{I_{\min}} = 1.76$$

(b) The value of the distance x is related to the parameter v in Fresnel's integral by

$$v = x \sqrt{\frac{2}{b\lambda}}.$$

For the first two maxima the distances x_1, x_2 are related to the parameters v_1, v_2 by

$$x_1 = \sqrt{\frac{b\lambda}{2}} v_1, \quad x_2 = \sqrt{\frac{b\lambda}{2}} v_2$$

Thus
$$(v_2 - v_1) \sqrt{\frac{b\lambda}{2}} = x_2 - x_1 = \Delta x$$

or
$$\lambda = \frac{2}{b} \left(\frac{\Delta x}{v_2 - v_1} \right)^2$$

From the Cornu's spiral the positions of the maxima are

$$v_1 = 1.22, \quad v_2 = 2.34, \quad v_3 = 3.08 \text{ etc}$$

Thus
$$\lambda = \frac{2}{b} \left(\frac{\Delta x}{1.12} \right)^2 = 0.63 \mu\text{m}.$$

5.112 We shall use the equation written down in 5.103, the Fresnel-Huyghens formula.

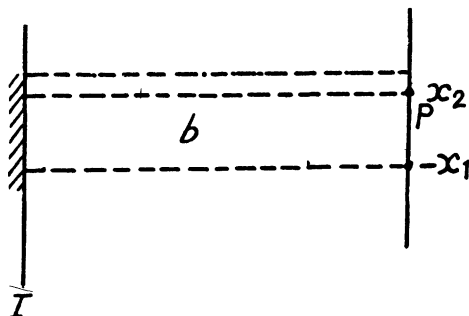

Suppose we want to find the intensity at P which is such that the coordinates of the edges (x -coordinates) with respect to P are x_2 and $-x_1$. Then, the amplitude at P is

$$E = \int K(\varphi) \frac{a_0}{r} e^{-ikr} dS$$

We write $dS = dx dy$, y is to be integrated from $-\infty + 0$ to $+\infty$. We write

$$r = b + \frac{x^2 + y^2}{2b} \tag{1}$$

(r is the distance of the element of surface on I from P . It is $\sqrt{b^2 + x^2 + y^2}$ and hence approximately (1)). We then get

$$E = A_0(b) \left[\int_{x_2}^{\infty} e^{-ikx^2/2b} dx + \int_{-\infty}^{-x_1} e^{-ikx^2/2b} dx \right]$$

$$= A'_0(b) \left[\int_{v_2}^{\infty} e^{-i\frac{\pi u^2}{2}} du + \int_{-\infty}^{-v_1} e^{-i\pi u^2/2} du \right]$$

where $v_2 = \sqrt{\frac{2}{b\lambda}} x_2$, $v_1 = \sqrt{\frac{2}{b\lambda}} x_1$

The intensity is the square of the amplitude. In our case, at the centre

$$v_1 = v_2 = \sqrt{\frac{2}{b\lambda}} \cdot \frac{a}{2} = \sqrt{\frac{a^2}{2b\lambda}} = 0.64$$

(a = width of the strip = 0.7 mm, b = 100 cm, λ = 0.60 μ m)

At, say, the lower edge $v_1 = 0$, $v_2 = 1.28$

Thus

$$\frac{I_{\text{centre}}}{I_{\text{edge}}} = \frac{\left| \int_{0.64}^{\infty} e^{-i\pi u^2/2} du + \int_{-\infty}^{-0.64} e^{-i\pi u^2/2} du \right|^2}{\left| \int_{1.28}^{\infty} e^{-i\pi u^2/2} du + \int_{-\infty}^0 e^{-i\pi u^2/2} du \right|^2} = 4 \frac{\left(\frac{1}{2} - C(0.64) \right)^2 + \left(\frac{1}{2} - S(0.64) \right)^2}{(1 - C(1.28))^2 + (1 - S(1.28))^2}$$

where $C(v) = \int_0^v \cos \frac{\pi u^2}{2} du$

$$S(v) = \int_0^v \sin \frac{\pi u^2}{2} du$$

Rough evaluation of the integrals using cornu's spiral gives

$$\frac{I_{\text{centre}}}{I_{\text{edge}}} \approx 2.4$$

$$\text{(We have used } \int_0^{\infty} \cos \frac{\pi u^2}{2} du = \int_0^{\infty} \sin \frac{\pi u^2}{2} du = \frac{1}{2}$$

$$C(0.64) = 0.62, S(0.64) = 0.15$$

$$C(1.28) = 0.65, S(1.28) = 0.67$$

5.113 If the aperture has width h then the parameters $(v, -v)$

associated with $\left(\frac{h}{2}, -\frac{h}{2}\right)$ are given by

$$v = \frac{h}{2} \sqrt{\frac{2}{b\lambda}} = h/\sqrt{2b\lambda}$$

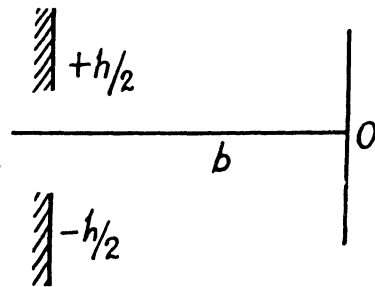

The intensity of light at O on the screen is obtained as the square of the amplitude A of the wave at O which is

$$A \sim \text{const} \int_{-v}^v e^{-i\pi u^2/2} du$$

Thus

$$I = 2I_0 ((C(v))^2 + (S(v))^2)$$

where $C(v)$ and $S(v)$ have been defined above and I_0 is the intensity at O due to an infinitely wide ($v = \infty$) aperture for then

$$I = 2I_0 \left(\left(\frac{1}{2}\right)^2 + \left(\frac{1}{2}\right)^2 \right) = 2I_0 \times \frac{1}{2} = I_0.$$

By definition v corresponds to the first minimum of the intensity. This means

$$v = v_1 \approx .90$$

when we increase h to $h + \Delta h$, the corresponding $v_2 = \frac{h + \Delta h}{\sqrt{2b\lambda}}$ relates to the second

minimum of intensity. From the cornu's spiral $v_2 \approx 2.75$

Thus

$$\Delta h = \sqrt{2b\lambda} (v_2 - v_1) = 0.85 \sqrt{2b\lambda}$$

or

$$\lambda = \left(\frac{\Delta h}{0.85}\right)^2 \frac{1}{2b} = \left(\frac{0.70}{0.85}\right)^2 \frac{1}{2 \times 0.6} \mu\text{m} = 0.565 \mu\text{m}$$

5.114 Let a = width of the recess and

$$v = \frac{a}{2} \sqrt{\frac{2}{b\lambda}} = \frac{a}{\sqrt{2b\lambda}} = \frac{0.6}{\sqrt{2 \times 0.77 \times 0.65}} = 0.60$$

be the parameter along Cornu's spiral corresponding to the half-width of the recess.

The amplitude of the diffracted wave is given by

$$\sim \text{const} \left[e^{i\delta} \int_{-v}^v e^{-i\pi u^2/2} du + \int_v^\infty e^{-i\pi u^2/2} du + \int_{-\infty}^{-v} e^{-i\pi u^2/2} du \right]$$

where $\delta = \frac{2\pi}{\lambda} (n-1)h$

is the extra phase due to the recess. (Actually an extra phase $e^{-i\delta}$ appears outside the recess. When we take it out and absorb it in the constant we get the expression written).

Thus the amplitude is

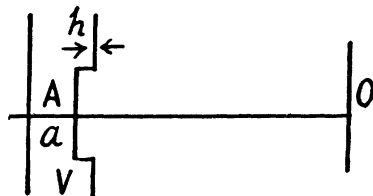

$$\sim \text{const} \left[(C(v) - iS(v)) e^{i\delta} + \left(\frac{1}{2} - C(v) \right) - i \left(\frac{1}{2} - S(v) \right) \right]$$

From the Cornu's spiral, the coordinates corresponding to the parameter $v = 0.60$ are

$$C(v) = 0.57, S(v) = 0.13$$

so the intensity at O is proportional to

$$\begin{aligned} & \left| \left[(0.57 - 0.13i) e^{i\delta} - 0.07 - i0.37 \right] \right|^2 \\ &= (0.57^2 + 0.13^2) + 0.07^2 + 0.37^2 \\ &+ (0.57 - 0.13i)(-0.07 + 0.37i) e^{i\delta} \\ &+ (0.57 + 0.13i)(-0.07 - i0.37i) e^{-i\delta} \end{aligned}$$

We write

$$\begin{aligned} 0.57 - 0.13i &= 0.585 e^{-i\alpha} \quad \alpha = 12.8^\circ \\ -0.07 \pm 0.37i &= 0.377 e^{\pm i\beta} \quad \beta = 100.7^\circ \end{aligned}$$

Thus the cross term is

$$\begin{aligned} & 2 \times 0.585 \times 0.377 \cos(\delta + 88^\circ) \\ &= 2 \times 0.585 \times 0.377 \cos\left(\delta + \frac{\pi}{2}\right) \end{aligned}$$

For maximum intensity

$$\begin{aligned} \delta + \frac{\pi}{2} &= 2k'\pi, \quad k' = 1, 2, 3, 4, \dots \\ &= 2(k+1)\pi, \quad k = 0, 1, 2, 3, \dots \end{aligned}$$

or

$$\delta = 2k\pi + \frac{3\pi}{2}$$

so

$$h = \frac{\lambda}{n-1} \left(k + \frac{3}{4} \right)$$

5.115

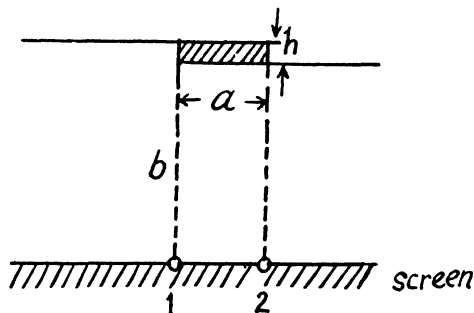

Using the method of problem 5.103 we can immediately write down the amplitudes at 1 and 2. We get :

$$\text{At 1} \quad \text{amplitude } A_1 \sim \text{const} \left[\int_{-\infty}^0 e^{-i\pi u^2/2} du + e^{-i\delta} \int_v^{\infty} e^{-i\pi u^2/2} du \right]$$

At 2 amplitude $A_2 \sim \text{const} \left[\int_{-\infty}^{-v} e^{-i\pi u^2/2} du + e^{-i\delta} \int_0^{\infty} e^{-i\pi u^2/2} du \right]$

where
$$v = a \sqrt{\frac{2}{b\lambda}}$$

is the parameter of Cornu's spiral and constant factor is common to 1 and 2.

With the usual notation

$$C = C(v) = \int_0^v \cos \frac{\pi u^2}{2} du$$

$$S = S(v) = \int_0^v \sin \frac{\pi u^2}{2} du$$

and the result
$$\int_0^{\infty} \cos \frac{\pi u^2}{2} du = \int_0^{\infty} \sin \frac{\pi u^2}{2} du = \frac{1}{2}$$

We find the ratio of intensities as

$$\frac{I_2}{I_1} = \left| \frac{\left(\frac{1}{2} - C \right) - i \left(\frac{1}{2} - S \right) + e^{-i\delta} \frac{(1-i)}{2}}{\frac{1-i}{2} + e^{-i\delta} \left\{ \left(\frac{1}{2} - C \right) - i \left(\frac{1}{2} - S \right) \right\}} \right|^2$$

(The constants in A_1 and A_2 must be the same by symmetry)

In our case, $a = 0.30 \text{ mm}$, $\lambda = 0.65 \mu\text{m}$, $b = 1.1 \text{ m}$

$$v = 0.30 \times \sqrt{\frac{2}{1.1 \times 0.65}} = 0.50$$

$$C(0.50) = 0.48 \quad S(0.50) = 0.06$$

$$\frac{I_2}{I_1} = \left| \frac{0.02 - 0.44i + e^{-i\delta} \frac{(1-i)}{2}}{\frac{1-i}{2} e^{i\delta} + 0.02 - 0.44i} \right|^2 = \left| \frac{1 + (0.02 - 0.44i)\sqrt{2} e^{i\delta + \frac{i\pi}{4}}}{1 + (0.02 - 0.44i)\sqrt{2} e^{-i\delta + \frac{i\pi}{4}}} \right|^2$$

But $0.02 - 0.44i = 0.44 e^{i\alpha}$, $\alpha = 1.525 \text{ rad} (\approx 87.4^\circ)$

$$\text{So } \frac{I_2}{I_1} = \left| \frac{1 + 0.44 \times \sqrt{2} \times e^{i(\delta - 0.740)}}{1 + 0.44 \times \sqrt{2} \times e^{-i(\delta + 0.740)}} \right|^2 = \frac{1 + 2(0.44)^2 + 2\sqrt{2} \times 0.44 \cos(\delta - 0.740)}{1 + 2(0.44)^2 + 2\sqrt{2} \times 0.44 \cos(\delta + 0.740)}$$

I_2 is maximum when $\delta - 0.740 = 0 \text{ (modulo } 2\pi \text{)}$

$$\text{Thus in that case } \frac{I_2}{I_1} = \frac{1.387 + 1.245}{1.387 + 1.245 \cos(1.48)} = \frac{2.632}{1.5} \approx 1.75$$

5.116 We apply the formula of problem 5.103 and calculate

$$\int_{\text{aperture}} \frac{a_0}{r} e^{-ikr} dS = \int_{\text{Semicircle}} + \int_{\text{Slit}}$$

The contribution of the full 1st Fresnel zone has been evaluated in 5.103. The contribution of the semi-circle is one half of it and is

$$-\frac{2\pi}{k} i a_0 e^{-ikb} = -i a_0 \lambda e^{-ikb}$$

The contribution of the slit is

$$\frac{a_0}{b} \int_0^{0.90\sqrt{b\lambda}} e^{-ikb} e^{-ik\frac{x^2}{2b}} dx \int_{-\infty}^{\infty} e^{-iky^2/2b} dy$$

Now

$$\int_{-\infty}^{\infty} e^{-iky^2/2b} dy = \int_{-\infty}^{\infty} e^{-i\frac{\pi y^2}{b\lambda}} dy$$

$$\sqrt{\frac{b\lambda}{2}} \int_{-\infty}^{\infty} e^{-i\pi u^2/2} du = \sqrt{b\lambda} e^{-i\pi/4}$$

Thus the contribution of the slit is

$$\begin{aligned} & \frac{a_0}{b} \sqrt{b\lambda} e^{-ikb - i\pi/4} \int_0^{0.90\sqrt{b\lambda}} e^{-i\pi u^2/2} du \sqrt{\frac{b\lambda}{2}} \\ &= a_0 \lambda e^{-ikb - i\pi/4} \frac{1}{\sqrt{2}} \int_0^{1.27} e^{-i\pi u^2/2} du \end{aligned}$$

Thus the intensity at the observation point P on the screen is

$$a_0^2 \lambda^2 \left| -i + \frac{1-i}{2} (C(1.27) - iS(1.27)) \right|^2 = a_0^2 \lambda^2 \left| -i + \frac{(1-i)(0.67 - 0.65i)}{2} \right|^2$$

(on using $C(1.27) = 0.67$ and $S(1.27) = 0.65$)

$$= a_0^2 \lambda^2 | -i + 0.01 - 0.66i |^2$$

$$= a_0^2 \lambda^2 | 0.01 - 1.66i |^2$$

$$= 2.76 a_0^2 \lambda^2$$

Now $a_0^2 \lambda^2$ is the intensity due to half of 1st Fresnel zone and is therefore equal to I_0 . (It can also be obtained by doing the x -integral over $-\infty$ to $+\infty$).

Thus

$$I = 2.76 I_0.$$

5.117 From the statement of the problem we know that the width of the slit = diameter of the first Fresnel zone = $2\sqrt{b\lambda}$ where b is the distance of the observation point from the slit.

We calculate the amplitudes by evaluating the integral of problem 5.103

We get

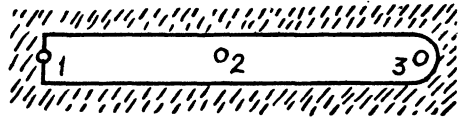

$$\begin{aligned}
 A_1 &= \frac{a_0}{b} \int_{-\sqrt{b\lambda}}^{\sqrt{b\lambda}} e^{-ikb} e^{-ik\frac{x^2}{2b}} dx \int_0^{\infty} e^{-ik\frac{y^2}{2b}} dy \\
 &= \frac{a_0}{b} e^{-ikb} \frac{b\lambda}{2} \int_{-\sqrt{2}}^{\sqrt{2}} e^{-i\pi u^2/2} du \times \int_0^{\infty} e^{-i\pi u^2/2} du \\
 &= \frac{a_0\lambda}{2} (1-i) e^{-ikb} \left(C(\sqrt{2}) - iS(\sqrt{2}) \right)
 \end{aligned}$$

$$\begin{aligned}
 A_2 &= \frac{a_0}{b} \int_{-\sqrt{b\lambda}}^{\sqrt{b\lambda}} e^{-ikb} e^{-ik\frac{x^2}{2b}} dx \int_{-\infty}^{\infty} e^{-iky^2/2b} dy \\
 &= 2A_1
 \end{aligned}$$

$$A_3 = -i a_0 \lambda e^{-ikb} + \frac{a_0 \lambda (1-i)}{2} \left(C(\sqrt{2}) - iS(\sqrt{2}) \right) e^{-ikb}$$

where the contribution of the 1st half Fresnel zone (in A_3 , first term) has been obtained from the last problem.

$$\begin{aligned}
 \text{Thus } I_1 &= a_0^2 \lambda^2 \left| \frac{(1-i)(0.53 - 0.72i)}{2} \right|^2 \\
 (\text{on using } C(\sqrt{2}) &= 0.53, S(\sqrt{2}) = 0.72) \\
 &= a_0^2 \lambda^2 | -0.095 - 0.625i |^2 = 0.3996 a_0^2 \lambda^2
 \end{aligned}$$

$$I_2 = 4I_1$$

$$\begin{aligned}
 I_3 &= a_0^2 \lambda^2 | -0.095 - 0.625i - i |^2 \\
 &= a_0^2 \lambda^2 | -0.095 - 1.625i |^2 \\
 &= 2.6496 a_0^2 \lambda^2
 \end{aligned}$$

So

$$I_3 = 6.6I_1$$

Thus

$$I_1 : I_2 : I_3 \approx 1 : 4 : 7$$

5.118 The radius of the first half Fresnel zone is $\sqrt{b\lambda/2}$ and the amplitude at P is obtained using problem 5.103.

$$A = \frac{a_0}{b} \left[\int_{-\infty}^{-\eta\sqrt{b\lambda/2}} + \int_{\eta\sqrt{b\lambda/2}}^{\infty} \right] e^{-ikb - \frac{kx^2}{2b}} dx$$

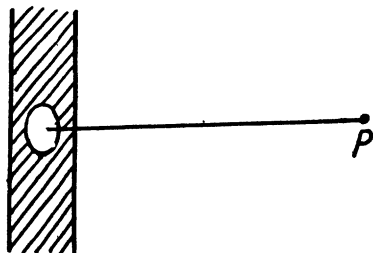

$$\int_{-\infty}^{\infty} e^{-iky^2/2b} dy + \frac{a_0}{b} e^{-ikb} \int_0^{\sqrt{b\lambda/2}} e^{-ik\rho^2/2b} 2\pi\rho d\rho.$$

We use

$$\begin{aligned} & \int_{-\infty}^{\infty} e^{-ikx^2/2b} dx \\ &= \int_{\eta\sqrt{b\lambda/2}}^{\infty} e^{-ikx^2/2b} dx = \int_{\eta\sqrt{b\lambda/2}}^{\infty} e^{-i\frac{\pi x^2}{b\lambda}} dx \\ &= \int_{\eta}^{\infty} e^{-i\pi u^2/2} \sqrt{\frac{b\lambda}{2}} du = \sqrt{\frac{b\lambda}{2}} \left(\int_0^{\infty} - \int_0^{\eta} \right) e^{-i\pi u^2/2} du. \\ &= \sqrt{\frac{b\lambda}{2}} \left(\left(\frac{1}{2} - C(\eta) \right) - i \left(\frac{1}{2} - S(\eta) \right) \right) \end{aligned}$$

Thus

$$\begin{aligned} A &= a_0 \frac{\lambda}{2} \times 2 \times (1-i) e^{-ikb} \left[\left(\frac{1}{2} - C(\eta) \right) \right. \\ &\quad \left. - i \left(\frac{1}{2} - S(\eta) \right) \right] + a_0 \lambda (1-i) e^{-ikb} \end{aligned}$$

where we have used

$$\int_0^{\sqrt{b\lambda/2}} e^{-ik\rho^2/2b} 2\pi\rho d\rho = \frac{2\pi ib}{k} (-1-i) = \frac{2\pi b}{k} (1-i) = \lambda b (1-i)$$

Thus the intensity is

$$I = |A|^2 = a_0^2 \lambda^2 \times 2 \left[\left(\frac{3}{2} - C(\eta) \right)^2 + \left(\frac{1}{2} - S(\eta) \right)^2 \right]$$

From Cornu's Spiral,

$$C(\eta) = C(1.07) = 0.76$$

$$S(\eta) = S(1.07) = 0.50$$

$$I = a_0^2 \lambda^2 \times 2 \times (0.74)^2 = 1.09 a_0^2 \lambda^2$$

As before

$$I_0 = a_0^2 \lambda^2 \text{ so } I = I_0.$$

5.119 If a plane wave is incident normally from the left on a slit of width b and the diffracted wave is observed at a large distance, the resulting pattern is called Fraunhofer diffraction. The condition for this is $b^2 \ll l\lambda$ where l is the distance between the slit and the screen. In practice light may be focussed on the screen with the help of a lens (or a telescope).

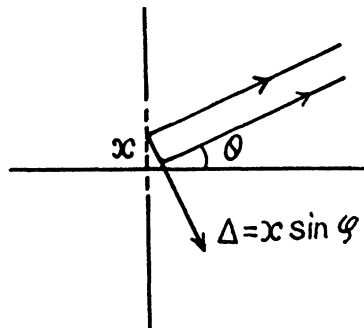

Consider an element of the slit which is an infinite strip of width dx . We use the formula of problem 5.103 with the following modifications.

The factor $\frac{1}{r}$ characteristic of spherical waves will be omitted. The factor $K(\varphi)$ will also be dropped if we confine ourselves to not too large φ . In the direction defined by the angle φ the extra path difference of the wave emitted from the element at x relative to the wave emitted from the centre is

$$\Delta = -x \sin \varphi$$

Thus the amplitude of the wave is given by

$$\begin{aligned} \alpha \int_{-b/2}^{+b/2} e^{ik \sin \varphi} dx &= \left(e^{i \frac{1}{2} kb \sin \varphi} - e^{-i \frac{1}{2} kb \sin \varphi} \right) / ik \sin \varphi \\ &= \frac{\sin \left(\frac{\pi b}{\lambda} \sin \varphi \right)}{\frac{\pi b}{\lambda} \sin \varphi} \end{aligned}$$

Thus

$$I = I_0 \frac{\sin^2 \alpha}{\alpha^2}$$

where

$$\alpha = \frac{\pi b}{\lambda} \sin \varphi \text{ and}$$

I_0 is a constant

Minima are observed for $\sin \alpha = 0$ but $\alpha \neq 0$

Thus we find minima at angles given by

$$b \sin \varphi = k\lambda, \quad k = \pm 1, \pm 2, \pm 3, \dots$$

5.120 Since $I(\alpha)$ is +ve and vanishes for $b \sin \varphi = k\lambda$ i.e for $\alpha = k\pi$, we expect maxima of $I(\alpha)$ between $\alpha = +\pi$ & $\alpha = +2\pi$, etc. We can get these values by.

$$\frac{d}{d\alpha}(I(\alpha)) = I_0 2 \frac{\sin \alpha}{\alpha} \frac{d}{d\alpha} \frac{\sin \alpha}{\alpha} = 0$$

$$\frac{\alpha \cos \alpha - \sin \alpha}{\alpha^2} = 0 \quad \text{or} \quad \tan \alpha = \alpha$$

Solutions of this transcendental equation can be obtained graphically.

The first three solutions are

$$\alpha_1 = 1.43\pi, \quad \alpha_2 = 2.46\pi, \quad \alpha_3 = 3.47\pi$$

on the +ve side. (On the negative side the solution are $-\alpha_1, -\alpha_2, -\alpha_3, \dots$)

Thus

$$b \sin \varphi_1 = 1.43 \lambda$$

$$b \sin \varphi_2 = 2.46 \lambda$$

$$b \sin \varphi_3 = 3.47 \lambda$$

Asymptotically the solutions are

$$b \sin \varphi_m \approx \left(M + \frac{1}{2}\right) \lambda$$

5.121 The relation $b \sin \theta = k\lambda$

for minima (when light is incident normally on the slit) has a simple interpretation : $b \sin \theta$ is the path difference between extreme wave normals emitted at angle θ

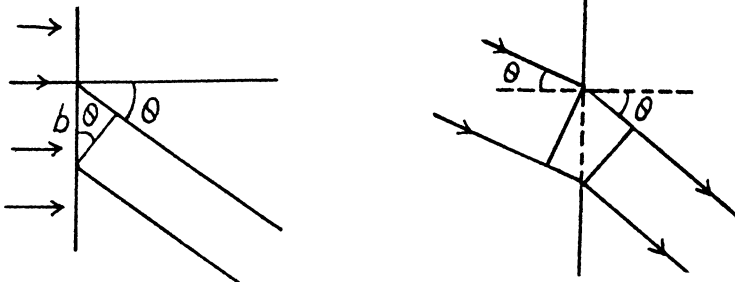

When light is incident at an angle θ_0 the path difference is

$$b (\sin \theta - \sin \theta_0)$$

and the condition of minima is

$$b (\sin \theta - \sin \theta_0) = k\lambda$$

For the first minima

$$b (\sin \theta - \sin \theta_0) = \pm \lambda \quad \text{or} \quad \sin \theta = \sin \theta_0 \pm \frac{\lambda}{b}$$

Putting in numbers $\theta_0 = 30^\circ$, $\lambda = 0.50 \mu\text{m}$ $b = 10 \mu\text{m}$

$$\sin \theta = \frac{1}{2} \pm \frac{1}{20} = 0.55 \quad \text{or} \quad 0.45$$

$$\theta_{+1} = 33^\circ - 20' \quad \text{and} \quad \theta_{-1} = 26^\circ 44'$$

- 5.122 (a) This case is analogous to the previous one except that the incident wave moves in glass of RI n . Thus the expression for the path difference for light diffracted at angle θ from the normal to the hypotenuse of the wedge is

$$b (\sin \theta - n \sin \Theta)$$

we write

$$\theta = \Theta + \Delta \theta$$

Then for the direction of principal Fraunhofer maximum

$$b (\sin (\Theta + \Delta \theta) - n \sin \Theta) = 0$$

or

$$\Delta \theta = \sin^{-1} (n \sin \Theta) - \Theta$$

Using

$$\Theta = 15^\circ, n = 1.5 \text{ we get}$$

$$\Delta \theta = 7.84^\circ$$

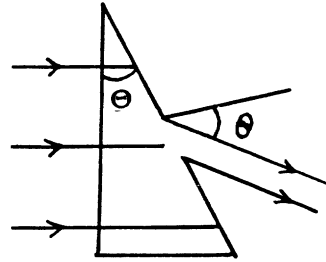

- (b) The width of the central maximum is obtained from ($\lambda = 0.60 \mu\text{m}$, $b = 10 \mu\text{m}$)

$$b (\sin \theta_{+1} - n \sin \Theta) = \pm \lambda$$

Thus

$$\theta_{+1} = \sin^{-1} \left(n \sin \Theta + \frac{\lambda}{b} \right) = 26.63^\circ$$

$$\theta_{-1} = \sin^{-1} \left(n \sin \Theta - \frac{\lambda}{b} \right) = 19.16^\circ$$

$$\therefore \delta \theta = \theta_{+1} - \theta_{-1} = 7.47^\circ$$

5.123

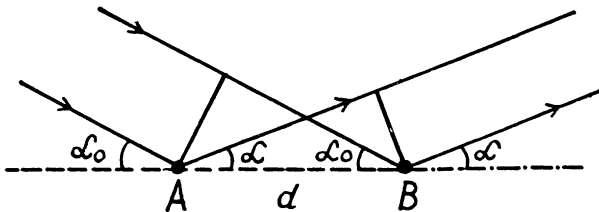

The path difference between waves reflected at A and B is

$$d (\cos \alpha_0 - \cos \alpha)$$

and for maxima

$$d (\cos \alpha_0 - \cos \alpha) = k \lambda, \quad k = 0, \pm 1, \pm 2, \dots$$

In our case, $k = 2$ and α_0, α are small in radians. Then

$$2 \lambda = d \left(\frac{\alpha^2 - \alpha_0^2}{2} \right)$$

Thus

$$\lambda - \frac{(\alpha^2 - \alpha_0^2) d}{4} = 0.61 \mu\text{m}$$

for

$$\alpha = \frac{3\pi}{180}, \quad \alpha_0 = \frac{\pi}{180}, \quad d = 10^{-3} \text{ m}$$

5.124 The general formula for diffraction from N slits is

$$I = I_0 \frac{\sin^2 \alpha}{\alpha^2} \frac{\sin^2 N \beta}{\sin^2 \beta}$$

where

$$\alpha = \frac{\pi a \sin \theta}{\lambda}$$

$$\beta = \frac{\pi (a + b) \sin \theta}{\lambda}$$

and $N = 3$ in the cases here.

(a) In this case $a + b = 2a$

so $\beta = 2\alpha$ and $I = I_0 \frac{\sin^2 \alpha}{\alpha^2} (3 - 4 \sin^2 2\alpha)^2$

On plotting we get a curve that qualitatively looks like the one below

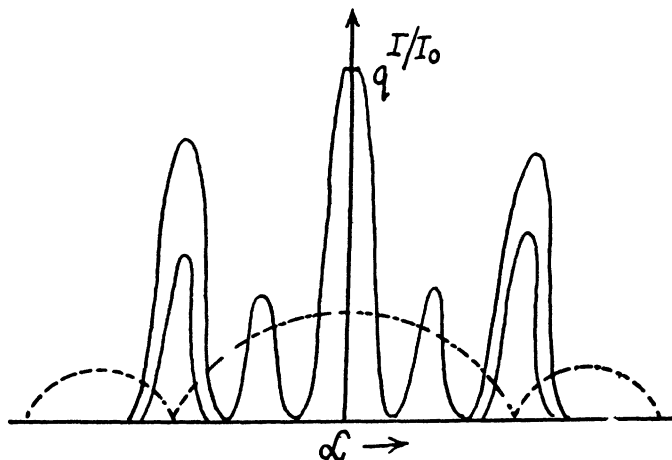

(b) In this case $a + b = 3a$

so

$$\beta = 3\alpha$$

and

$$I = I_0 \frac{\sin^2 \alpha}{\alpha^2} (2 - 4 \sin^2 3\alpha)^2$$

This has 3 minima between the principal maxima

5.125 From the formula $d \sin \theta = m \lambda$

we have $d \sin 45^\circ = 2 \lambda_1 = 2 \times 0.65 \mu\text{m}$

or

$$d = 2\sqrt{2} \times 0.65 \mu\text{m}$$

Then for $\lambda_2 = 0.50$ in the third order

$$2\sqrt{2} \times 0.65 \sin \theta = 3 \times 0.50$$

$$\sin \theta = \frac{1.5}{1.3 \times \sqrt{2}} = 0.81602$$

This gives $\theta = 54.68^\circ \approx 55^\circ$

5.126 The diffraction formula is

$$d \sin \theta_0 = n_0 \lambda$$

where $\theta_0 = 35^\circ$ is the angle of diffraction corresponding to order n_0 (which is not yet known).

Thus

$$d = \frac{n_0 \lambda}{\sin \theta_0} = n_0 \times 0.9327 \mu\text{m}$$

on using $\lambda = 0.535 \mu\text{m}$

For the n^{th} order we get

$$\sin \theta = \frac{n}{n_0} \sin \theta_0 = \frac{n}{n_0} (0.573576)$$

If $n_0 = 1$, then $n > n_0$ is at least 2 and $\sin \theta > 1$ so $n = 1$ is the highest order of diffraction.

If $n_0 = 2$ then $n = 3, 4$, but $\sin \theta > 1$ for $n = 4$ thus the highest order of diffraction is 3.

If $n_0 = 3$,

then

$$n = 4, 5, 6.$$

For $n = 6$, $\sin \theta = 2 \times 0.57 > 1$, so not allowed while for

$$n = 5, \sin \theta = \frac{5}{3} \times 0.573576 < 1$$

is allowed. Thus in this case the highest order of diffraction is five as given. Hence

$$n_0 = 3$$

and

$$d = 3 \times 0.9327 = 2.7981 \approx 2.8 \mu\text{m}.$$

5.127 Given that

$$d \sin \theta_1 = \lambda$$

$$d \sin \theta_2 = d \sin (\theta_1 + \Delta \theta) = 2 \lambda$$

Thus

$$\sin \theta_1 \cos \Delta \theta + \cos \theta_1 \sin \Delta \theta = 2 \sin \theta_1$$

or

$$\sin \theta_1 (2 - \cos \Delta \theta) = \cos \theta_1 \sin \Delta \theta$$

or

$$\tan \theta_1 = \frac{\sin \Delta \theta}{2 - \cos \Delta \theta}$$

or

$$\begin{aligned} \sin \theta_1 &= \frac{\sin \Delta \theta}{\sqrt{\sin^2 \Delta \theta + (2 - \cos \Delta \theta)^2}} \\ &= \frac{\sin \Delta \theta}{\sqrt{5 - 4 \cos \Delta \theta}} \end{aligned}$$

Finally

$$\lambda = \frac{d \sin \Delta \theta}{\sqrt{5 - 4 \cos \Delta \theta}}.$$

Substitution gives $\lambda \approx 0.534 \mu\text{m}$

5.128 (a) Here the simple formula

$$d \sin \theta = m_1 \lambda \text{ holds.}$$

Thus

$$1.5 \sin \theta = m \times 0.530 \quad \sin \theta = \frac{m \times 0.530}{1.5}$$

Highest permissible m is $m = 2$ because $\sin \theta > 1$ if $m = 3$. Thus

$$\sin \theta = \frac{1.06}{1.50} \text{ for } m = 2, \text{ This gives } \theta = 45^\circ \text{ nearby.}$$

(b) Here $d(\sin \theta_0 - \sin \theta) = n\lambda$

$$\begin{aligned} \text{Thus } \sin \theta &= \sin \theta_0 - \frac{n\lambda}{d} \\ &= \sin 60^\circ - n \times \frac{0.53}{1.5} \\ &= 0.86602 - n \times 0.353333. \end{aligned}$$

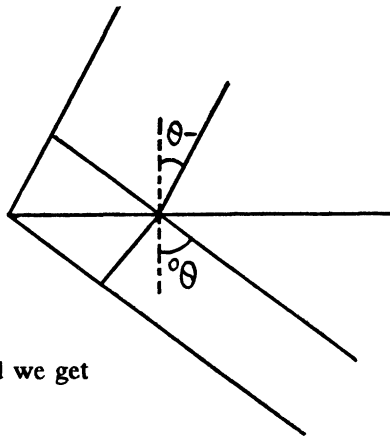

For $n = 5$, $\sin \theta = -0.900645$

for $n = 6$, $\sin \theta < -1$.

Thus the highest order is $n = 5$ and we get

$$\theta = \sin^{-1}(-0.900645) \approx -64^\circ$$

5.129 For the lens

$$\frac{1}{f} = (n-1) \left(\frac{1}{R} - \frac{1}{\infty} \right) \text{ or } f = \frac{R}{n-1}$$

For the grating

$$d \sin \theta_1 = \lambda \text{ or } \sin \theta_1 = \frac{\lambda}{d}$$

$$\operatorname{cosec} \theta_1 = \frac{d}{\lambda}, \cot \theta_1 = \sqrt{\left(\frac{d}{\lambda}\right)^2 - 1}$$

$$\tan \theta_1 = \frac{1}{\sqrt{\left(\frac{d}{\lambda}\right)^2 - 1}}$$

Hence the distance between the two symmetrically placed first order maxima

$$= 2f \tan \theta_1 = \frac{2R}{(n-1) \sqrt{\left(\frac{d}{\lambda}\right)^2 - 1}}$$

On putting $R = 20$, $n = 1.5$, $d = 6.0 \mu\text{m}$

$$\lambda = 0.60 \mu\text{m} \text{ we get } 8.04 \text{ cm.}$$

5.130 The diffraction formula is easily obtained on taking account of the fact that the optical path in the glass wedge acquires a factor n (refractive index). We get

$$d(n \sin \Theta - \sin(\Theta - \theta_k)) = k\lambda$$

Since $n > 0$, $\Theta - \theta_0 > \Theta$ and so θ_0 must be negative. We get, using $\Theta = 30^\circ$

$$\frac{3}{2} \times \frac{1}{2} = \sin(30^\circ - \theta_0) = \sin 48.6^\circ$$

Thus

$$\theta_0 = -18.6^\circ$$

Also for $k = 1$

$$\frac{3}{4} - \sin(30^\circ - \theta_{+1}) = \frac{\lambda}{d} = \frac{0.5}{2.0} = \frac{1}{4}$$

Thus

$$\theta_{+1} = 0^\circ$$

We calculate θ_k for various k by the above formula. For $k = 6$.

$$\sin(\theta_k - 30^\circ) = \frac{3}{4} \Rightarrow \theta_k = 78.6^\circ$$

For $k = 7$

$$\sin(\theta_k - 30^\circ) = +1 \Rightarrow \theta_k = 120^\circ$$

This is inadmissible. Thus the highest order that can be observed is

$$k = 6$$

corresponding to

$$\theta_k = 78.6^\circ$$

(for $k = 7$ the diffracted ray will be grazing the wedge).

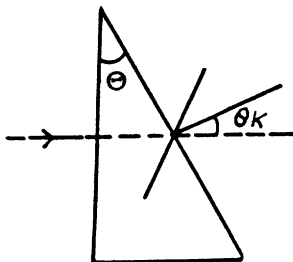

- 5.131** The intensity of the central Fraunhofer maximum will be zero if the waves from successive grooves (not in the same plane) differ in phase by an odd multiple of π . Then since the phase difference is

$$\delta = \frac{2\pi}{\lambda}(n-1)h$$

for the central ray we have

$$\frac{2\pi}{\lambda}(n-1)h = \left(k - \frac{1}{2}\right)2\pi, \quad k = 1, 2, 3, \dots$$

or

$$h = \frac{\lambda}{n-1} \left(k - \frac{1}{2}\right).$$

The path difference between the rays 1 & 2 is approximately (neglecting terms of order θ^2)

$$a \sin \theta + a - n a$$

$$= a \sin \theta - (n-1)a$$

Thus for a maximum

$$a \sin \theta - \left(k' + \frac{1}{2}\right)\lambda = m\lambda$$

$$\text{or } a \sin \theta = \left(m + k' + \frac{1}{2}\right)\lambda,$$

$$k' = 0, 1, 2, \dots$$

$$m = 0, \pm 1, \pm 2, \dots$$

The first maximum after the central minimum is obtained when $m + k' = 0$

We get

$$a \sin \theta_1 = \frac{1}{2}\lambda$$

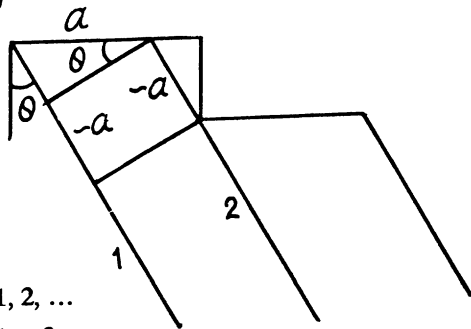

5.132 When standing ultra sonic waves are sustained in the tank it behaves like a grating whose grating element is

$$d = \frac{v}{\nu} = \text{wavelength of the ultrasonic}$$

ν = velocity of ultrasonic. Thus for maxima

$$\frac{v}{\nu} \sin \theta_m = m \lambda$$

On the other hand

$$f \tan \theta_m = m \Delta x$$

Assuming θ_m to be small (because $\lambda \ll \frac{v}{\nu}$)

$$\text{we get } \Delta x = \frac{f \tan \theta_m}{m} = \frac{f \tan \theta_m}{\frac{v}{\nu} \sin \theta_m} = \frac{\lambda \nu f}{v}$$

$$\text{or } v = \frac{\lambda \nu f}{\Delta x}$$

Putting the values $\lambda = 0.55 \mu\text{m}$, $\nu = 4.7 \text{ MHz}$

$f = 0.35 \text{ m}$ and $\Delta x = 0.60 \times 10^{-3} \text{ m}$ we easily get

$$v = 1.51 \text{ km/sec.}$$

5.133 Each star produces its own diffraction pattern in the focal plane of the objective and these patterns are separated by angle ψ . As the distance d decreases the angle θ between the neighbouring maxima in either diffraction pattern increases ($\sin \theta = \lambda/d$). When θ becomes equal to 2ψ the first deterioration of visibility occurs because the maxima of one system of fringes coincide with the minima of the other system. Thus from the condition

$\theta = 2\psi$ and $\sin \theta = \frac{\lambda}{d}$ we get

$$\psi = \frac{1}{2} \theta = \frac{\lambda}{2d} \text{ (radians)}$$

Putting the values we get $\psi = 0.06''$

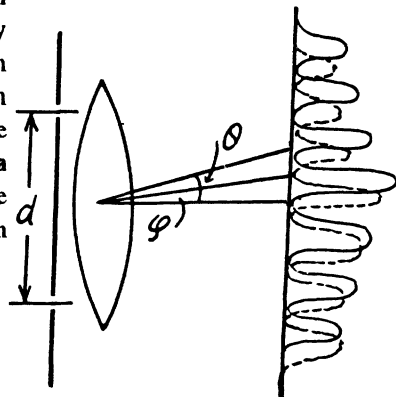

5.134 (a) For normal incidence, the maxima are given by

$$d \sin \theta = n \lambda$$

$$\text{so } \sin \theta = n \frac{\lambda}{d} = n \times \frac{0.530}{1.500}$$

Clearly $n \leq 2$ as $\sin \theta > 1$ for $n = 3$.

Thus the highest order is $n = 2$. Then

$$D = \frac{d\theta}{d\lambda} = \frac{k}{d \cos \theta} = \frac{k}{d} \frac{1}{\sqrt{1 - \left(\frac{k\lambda}{d}\right)^2}}$$

Putting $k = 2$, $\lambda = 0.53 \mu\text{m}$, $d = 1.5 \mu\text{m} = 1500 \text{ nm}$

$$\text{we get } D = \frac{2}{1500} \frac{1}{\sqrt{1 - \left(\frac{1.06}{1.5}\right)^2}} \times \frac{180}{\pi} \times 60 = 6.47 \text{ ang. min./nm.}$$

(b) We write the diffraction formula as

$$d(\sin \theta_0 + \sin \theta) = k\lambda$$

$$\text{so } \sin \theta_0 + \sin \theta = k \frac{\lambda}{d}$$

Here $\theta_0 = 45^\circ$ and $\sin \theta_0 = 0.707$

so $\sin \theta_0 + \sin \theta \leq 1.707$. Since

$$\frac{\lambda}{d} = \frac{0.53}{1.5} = 0.353333, \text{ we see that}$$

$$k \leq 4$$

Thus highest order corresponds to $k = 4$.

Now as before $D = \frac{d\theta}{d\lambda}$ so

$$D = \frac{k}{d \cos \theta} = \frac{k/d}{\sqrt{1 - \left(\frac{k\lambda}{d} - \sin \theta_0\right)^2}}$$

$$= 12.948 \text{ ang. min./nm,}$$

5.135 We have

$$d \sin \theta = k\lambda$$

so

$$\frac{d\theta}{d\lambda} = D = \frac{k}{d \cos \theta} = \frac{\tan \theta}{\lambda}$$

5.136 For the second order principal maximum

$$d \sin \theta_2 = 2\lambda = k\lambda$$

or

$$\frac{N\pi}{\lambda} d \sin \theta_2 = 2N\pi$$

minima adjacent to this maximum occur at

$$\frac{N\pi}{\lambda} d \sin (\theta_2 \pm \Delta \theta) = (2N \pm 1) \pi$$

or

$$d \cos \theta_2 \Delta \theta = \frac{\lambda}{N}$$

Finally angular width of the 2nd principal maximum is

$$2 \Delta \theta = \frac{2 \lambda}{N d \cos \theta_2} = \frac{2 \lambda}{N d \sqrt{1 - (k \lambda / d)^2}} = \frac{\tan \theta_2}{N}$$

On putting the values we get 11.019'' of arc

5.137 Using

$$\begin{aligned} R &= \frac{\lambda}{\delta \lambda} = kN = \frac{N d \sin \theta}{\lambda} \\ &= \frac{l \sin \theta}{\lambda} \leq \frac{l}{\lambda}. \end{aligned}$$

5.138 For the just resolved waves the frequency difference

$$\begin{aligned} \delta \nu &= \frac{c \delta \lambda}{\lambda} = \frac{c}{\lambda R} = \frac{c}{\lambda k N} \\ &= \frac{c}{N d \sin \theta} = \frac{1}{\delta t} \end{aligned}$$

since $N d \sin \theta$ is the path difference between waves emitted by the extremities of the grating.

5.139 $\delta \lambda = .050 \text{ nm}$

$$\begin{aligned} R &= \frac{\lambda}{\delta \lambda} = \frac{600}{.05} = 12000 \text{ (nearly)} \\ &= kN \end{aligned}$$

On the other hand

$$d \sin \theta = k \lambda$$

Thus
$$\frac{l}{kN} \sin \theta = \lambda$$

where $l = 10^{-2}$ metre is the width of the grating

Hence
$$\begin{aligned} \sin \theta &= 12000 \times \frac{\lambda}{l} \\ &= 12000 \times 600 \times 10^{-7} = 0.72 \end{aligned}$$

or

$$\theta = 46^\circ.$$

5.140 (a) We see that

$$N = 6.5 \times 10 \times 200 = 13000$$

Now to resolve lines with $\delta \lambda = 0.015 \text{ nm}$ and $\lambda = 670.8 \text{ nm}$ we must have

$$R = \frac{670.8}{0.015} = 44720$$

Since $3N < R < 4N$ one must go to the fourth order to resolve the said components.

(b) we have $d = \frac{1}{200} \text{ mm} = 5 \mu \text{ m}$

so
$$\sin \theta = \frac{k \lambda}{d} = \frac{k \times 0.670}{5}$$

since $|\sin \theta| \leq 1$ we must have $k \leq 7.46$

so
$$k_{\max} = 7 \approx \frac{d}{\lambda}$$

Thus
$$R_{\max} = k_{\max} N = 91000 \approx \frac{Nd}{\lambda} = \frac{l}{\lambda}$$

where $l = 6.5$ cm is the grating width.

Finally
$$\delta \lambda_{\min} = \frac{\lambda}{R_{\max}} = \frac{670}{91000} = 0.007 \text{ nm} = 7 \text{ pm} \approx \frac{\lambda^2}{l}$$

5.141 Here

$$R = \frac{\lambda}{\delta \lambda} = \frac{589.3}{0.6} = \text{kN} = 5 \text{ N}$$

so
$$N = \frac{589.3}{3} = \frac{10^{-2}}{d}$$

$$d = \frac{3 \times 10^{-2}}{589.3} \text{ m} = 0.0509 \text{ mm}$$

(b) To resolve a doublet with $\lambda = 460.0$ nm and $\delta \lambda = 0.13$ nm in the third order we must have

$$N = \frac{R}{3} = \frac{460}{3 \times 0.13} = 1179$$

This means that the grating is

$$Nd = 1179 \times 0.0509 = 60.03 \text{ mm}$$

wide = 6 cm wide.

5.142 (a) From $d \sin \theta = k \lambda$

we get
$$\delta \theta = \frac{k \delta \lambda}{d \cos \theta}$$

On the other hand
$$x = f \sin \theta$$

so
$$\delta x = f \cos \theta \delta \theta = \frac{k f}{d} \delta \lambda$$

For $f = 0.80$ m, $\delta \lambda = 0.03$ nm† and

$$d = \frac{1}{250} \text{ mm}$$

we get
$$\delta x = \begin{cases} 6 \mu\text{m} & \text{if } k = 1 \\ 12 \mu\text{m} & \text{if } k = 2 \end{cases}$$

(b) Here $N = 25 \times 250 = 6250$

and
$$\frac{\lambda}{\delta \lambda} = \frac{310.169}{0.03} = 10339 \dots > N$$

and so to resolve we need $k = 2$ For $k = 1$ gives an R.P. of only 6250.

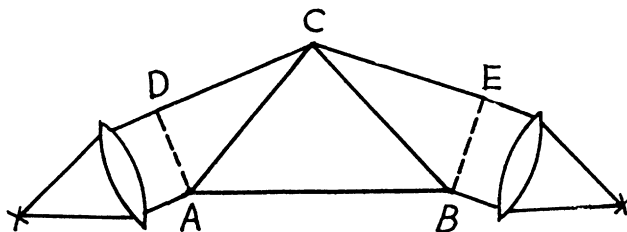

Suppose the incident light consists of two wavelengths λ and $\lambda + \delta \lambda$ which are just resolved by the prism. Then by Rayleigh's criterion, the maximum of the line of wavelength λ must coincide with the first minimum of the line of wavelength $\lambda + \delta \lambda$. Let us write both conditions in terms of the optical path differences for the extreme rays :

For the light of wavelength λ

$$b n - (DC + CE) = 0$$

For the light of wavelength $\lambda + \delta \lambda$

$$b(n + \delta n) - (DC + CE) = \lambda + \delta \lambda$$

because the path difference between extreme rays equals λ for the first minimum in a single slit diffraction (from the formula $a \sin \theta = \lambda$).

Hence

$$b \delta n \approx \lambda$$

and

$$R = \frac{\lambda}{\delta \lambda} = b \left| \frac{\delta n}{\delta \lambda} \right| = b \left| \frac{dn}{d\lambda} \right|$$

$$5.144 \quad (a) \quad \frac{\lambda}{\delta \lambda} = R = b \left| \frac{dn}{d\lambda} \right| = 2Bb/\lambda^3$$

$$\text{For } b = 5 \text{ cm}, B = 0.01 \mu\text{m}^2 \quad \lambda_1 = 0.434 \mu\text{m} = 5 \times 10^4 \mu\text{m}$$

$$R_1 = 1.223 \times 10^4$$

for

$$\lambda_2 = 0.656 \mu\text{m}$$

$$R_2 = 0.3542 \times 10^4$$

(b) To resolve the *D*-lines we require

$$R = \frac{5893}{6} = 982$$

Thus

$$982 = \frac{0.02 \times b}{(0.5893)^3}$$

$$b = \frac{982 \times (0.5893)^3}{0.02} \mu\text{m} = 1.005 \times 10^4 \mu\text{m} = 1.005 \text{ cm}$$

$$5.145 \quad b \left| \frac{dn}{d\lambda} \right| = kN = 2 \times 10,000$$

$$b \times 0.10 \mu\text{m}^{-1} = 2 \times 10^4$$

$$b = 2 \times 10^5 \mu\text{m} = 0.2 \text{ m} = 20 \text{ cm}.$$

5.146 Resolving power of the objective

$$= \frac{D}{1.22 \lambda} = \frac{5 \times 10^{-2}}{1.22 \times 0.55 \times 10^{-6}} = 7.45 \times 10^4$$

Let $(\Delta y)_{\min}$ be the minimum distance between two points at a distance of 3.0 km which the telescope can resolve. Then

$$\frac{(\Delta y)_{\min}}{3 \times 10^3} = \frac{1.22 \lambda}{D} = \frac{1}{7.45 \times 10^4}$$

or
$$(\Delta y)_{\min} = \frac{3 \times 10^3}{7.45 \times 10^4} = 0.04026 \text{ m} = 4.03 \text{ cm} .$$

5.147 The limit of resolution of a reflecting telescope is determined by diffraction from the mirror and obeys a formula similar to that from a refracting telescope. The limit of resolution is

$$\frac{1}{R} = \frac{1.22 \lambda}{D} = \frac{(\Delta y)_{\min}}{L}$$

where L = distance between the earth and the moon = 384000 km

Then putting the values $\lambda = 0.55 \mu\text{m}$, $D = 5 \text{ m}$

we get

$$(\Delta y)_{\min} = 51.6 \text{ metre}$$

5.148 By definition, the magnification

$$\Gamma = \frac{\text{angle subtended by the image at the eye}}{\text{angle subtended by the object at the eye}} = \frac{\psi'}{\psi}$$

At the limit of resolution

$$\psi = \frac{1.22 \lambda}{D}$$

where D = diameter of the objective

On the other hand to be visible to the eye $\psi' \geq \frac{1.22 \lambda}{d_0}$

where d_0 = diameter of the pupil

Thus to avail of the resolution offered by the telescope we must have

$$\Gamma \geq \frac{1.22 \lambda}{d_0} / \frac{1.22 \lambda}{D} = \frac{D}{d_0}$$

Hence

$$\Gamma_{\min} = \frac{D}{d_0} = \frac{50 \text{ mm}}{4 \text{ mm}} = 12.5$$

5.149

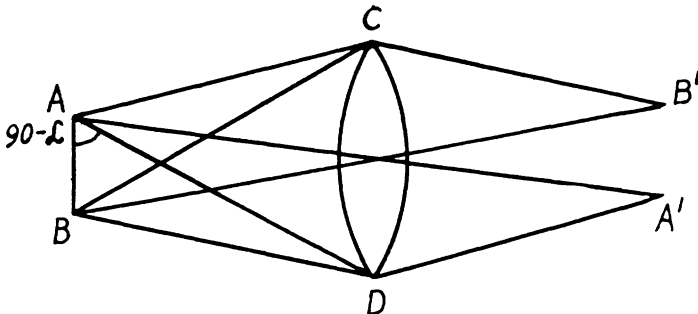

Let A and B be two points in the field of a microscope which is represented by the lens C . Let A', B' be their image points which are at equal distances from the axis of the lens CD . Then all paths from A to A' are equal and the extreme difference of paths from A to B' is equal to

$$\begin{aligned} & ADB' - ACB' \\ &= AD + DB' - (AC + CB') \\ &= AD + DB' - BD - DB' \\ &\quad + BC + CB' - AC - CB' \\ & \text{(as } BD + DB' = BC + CB') \\ &= AD - BD + BC - AC \\ &= 2AB \cos(90^\circ - \alpha) = 2AB \sin \alpha \end{aligned}$$

From the theory of diffraction by circular apertures this distance must be equal to 1.22λ

when B' coincides with the minimum of the diffraction due to A and A' with the minimum of the diffraction due to B . Thus

$$AB = \frac{1.22\lambda}{2 \sin \alpha} = 0.61 \frac{\lambda}{\sin \alpha}$$

Here 2α is the angle subtended by the objective of the microscope at the object.

Substituting the values

$$AB = \frac{0.61 \times 0.55}{0.24} \mu\text{m} = 1.40 \mu\text{m}.$$

5.150 Suppose d_{min} = minimum separation resolved by the microscope

ψ = angle subtended at the eye by this object when the object is at the least distance of distinct vision l_0 ($= 25 \text{ cm}$).

$$\psi' = \text{minimum angular separation resolved by the eye} = \frac{1.22\lambda}{d_0}$$

From the previous problem

$$d_{\text{min}} = \frac{0.61\lambda}{\sin \alpha}$$

and

$$\psi = \frac{d_{\text{min}}}{l_0} = \frac{0.61\lambda}{l_0 \sin \alpha}$$

Now

$$\Gamma = \text{magnifying power} = \frac{\text{angle subtended at the eye by the image}}{\text{angle subtended at the eye by the object}}$$

when the object is at the least distance of distinct vision

$$\geq \frac{\psi'}{\psi} = 2 \left(\frac{l_0}{d_0} \right) \sin \alpha$$

Thus

$$\Gamma_{\text{min}} = 2 \left(\frac{l_0}{d_0} \right) \sin \alpha = 2 \times \frac{25}{0.4} \times 0.24 = 30$$

5.151 Path difference

$$= BC - AD$$

$$= a (\cos 60^\circ - \cos \alpha)$$

For diffraction maxima

$$a (\cos 60^\circ - \cos \alpha) = k \lambda,$$

since $\lambda = \frac{2}{5} a$, we get

$$\cos \alpha = \frac{1}{2} - \frac{2}{5} k$$

and we get

$$k = -1, \cos \alpha = \frac{1}{2} + \frac{2}{5} = 0.9, \alpha = 26^\circ$$

$$k = 0, \cos \alpha = \frac{1}{2} = 0.5, \alpha = 60^\circ$$

$$k = 1, \cos \alpha = \frac{1}{2} - \frac{2}{5} = 0.1, \alpha = 84^\circ$$

$$k = 2, \cos \alpha = \frac{1}{2} - \frac{4}{5} = -0.3, \alpha = 107.5^\circ$$

$$k = 3, \cos \alpha = \frac{1}{2} - \frac{6}{5} = -0.7, \alpha = 134.4^\circ$$

Other values of k are not allowed as they lead to $|\cos \alpha| > 1$.

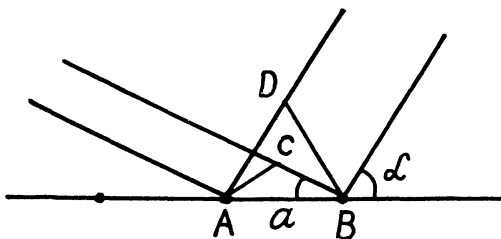

5.152 We give here a simple derivation of the condition for diffraction maxima, known as Laue equations. It is easy to see from the above figure that the path difference between waves scattered by nearby scattering centres P_1 and P_2 is

$$\begin{aligned} P_2A - P_1B &= \vec{r} \cdot \vec{s}_0 - \vec{r} \cdot \vec{s} \\ &= \vec{r} \cdot (\vec{s}_0 - \vec{s}) = \vec{r} \cdot \vec{S}. \end{aligned}$$

Here \vec{r} is the radius vector $\vec{P}_1\vec{P}_2$. For maxima this path difference must be an integer multiple of λ for any two neighbouring atoms. In the present case of two dimensional lattice with X-rays incident normally $\vec{r} \cdot \vec{s} = 0$. Taking successively nearest neighbours in the x - & y - directions

We get the equations

$$a \cos \alpha = h \lambda$$

$$b \cos \beta = k \lambda$$

Here $\cos \alpha$ and $\cos \beta$ are the direction cosines of the ray with respect to the x & y axes of the two dimensional crystal.

$$\cos \alpha = \frac{\Delta x}{\sqrt{(\Delta x)^2 + 4l^2}} = \sin \left(\tan^{-1} \frac{\Delta x}{2l} \right) = 0.28735$$

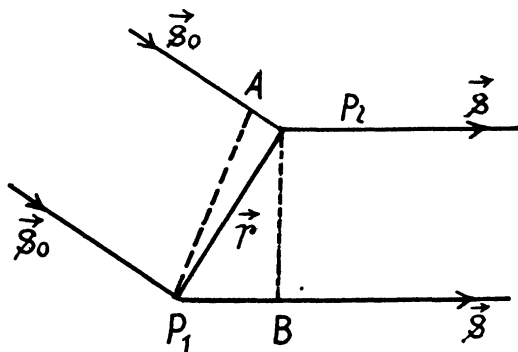

so using

$$h = k = 2 \text{ we get}$$

$$a = \frac{40 \times 2}{28735} \text{ pm} = 0.278 \text{ nm}$$

Similarly

$$\cos \beta = \frac{\Delta y}{\sqrt{(\Delta y)^2 + 4l^2}} = \sin \left(\tan^{-1} \frac{\Delta y}{2l} \right) = 0.19612$$

$$b = \frac{80}{\cos \beta} \text{ pm} = 0.408 \text{ nm}$$

5.153 Suppose α , β , and γ are the angles between the direction to the diffraction maximum and the directions of the array along the periods a , b , and c respectively (call them x , y , & z axes). Then the value of these angles can be found from the following familiar conditions

$$a(1 - \cos \alpha) = k_1 \lambda$$

$$b \cos \beta = k_2 \lambda \text{ and } c \cos \gamma = k_3 \lambda$$

where k_1 , k_2 , k_3 are whole numbers (+, -, or 0)

(These formulas are, in effect, Laue equations, see any text book on modern physics). Squaring

and adding we get on using $\cos^2 \alpha + \cos^2 \beta + \cos^2 \gamma = 1$

$$2 - 2 \cos \alpha = \left[\left(\frac{k_1}{a} \right)^2 + \left(\frac{k_2}{b} \right)^2 + \left(\frac{k_3}{c} \right)^2 \right] \lambda^2 = \frac{2k_1 \lambda}{a}$$

Thus

$$\lambda = \frac{2k_1/a}{\left[(k_1/a)^2 + (k_2/a)^2 + (k_3/a)^2 \right]}$$

Knowing a , b , c and the integer k_1 , k_2 , k_3 we can find α , β , γ as well as λ .

5.154 The unit cell of NaCl is shown below. In an infinite crystal, there are four Na^+ and four Cl^- ions per unit cell. (Each ion on the middle of the edge is shared by four unit cells; each ion on the face centre by two unit cells, the ion in the middle of the cell by one cell only and finally each ion on the corner by eight unit cells.) Thus

$$4 \frac{M}{N_A} = \rho \cdot a^3$$

where M = molecular weight of NaCl in gms
= 58.5 gms

N_A = Avogadro number = 6.023×10^{23}

Thus

$$\frac{1}{2} a = \sqrt{\frac{M}{2N_A \rho}} = 2.822 \text{ \AA}$$

The natural facet of the crystal is one of the faces of the unit cell. The interplanar distance

$$d = \frac{1}{2} a = 2.822 \text{ \AA}$$

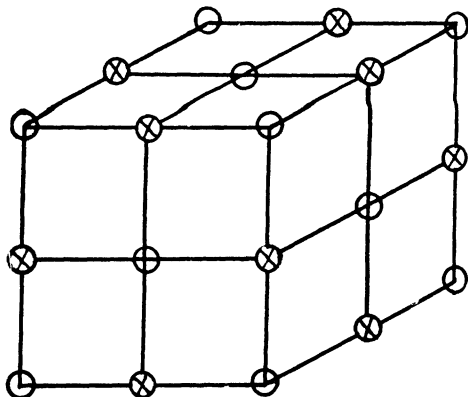

Thus

$$2d \sin \alpha = 2\lambda$$

So

$$\lambda = d \sin \alpha = 2.822 \text{ \AA} \times \frac{\sqrt{3}}{2} = 244 \text{ pm.}$$

5.155 When the crystal is rotated, the incident monochromatic beam is diffracted from a given crystal plane of interplanar spacing d whenever in the course of rotation the value of θ satisfies the Bragg equation.

We have the equations $2d \sin \theta_1 = k_1 \lambda$ and $2d \sin \theta_2 = k_2 \lambda$

But $\pi - 2\theta_1 = \pi - 2\theta_2 + \alpha$ or $2\theta_1 = 2\theta_2 - \alpha$

so $\theta_2 = \theta_1 + \frac{\alpha}{2}$.

Thus $2d \left\{ \sin \theta_1 \cos \frac{\alpha}{2} + \cos \theta_1 \sin \frac{\alpha}{2} \right\} = k_2 \lambda$

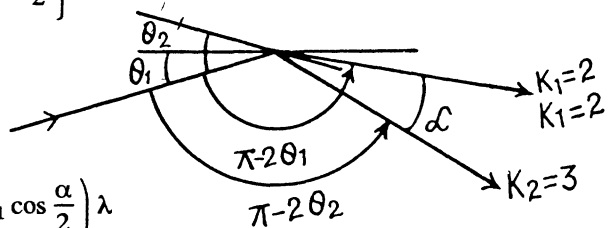

Hence $2d \sin \frac{\alpha}{2} \cos \theta_1 = \left(k_2 - k_1 \cos \frac{\alpha}{2} \right) \lambda$

also $2d \sin \frac{\alpha}{2} \sin \theta_1 = k_1 \lambda \sin \frac{\alpha}{2}$

Squaring and adding $2d \sin \frac{\alpha}{2} = \left(k_1^2 + k_2^2 - 2k_1 k_2 \cos \frac{\alpha}{2} \right)^{1/2} \lambda$

Hence $d = \frac{\lambda}{2 \sin \frac{\alpha}{2}} \left[k_1^2 + k_2^2 - 2k_1 k_2 \cos \frac{\alpha}{2} \right]^{1/2}$

Substituting $\alpha = 60^\circ$, $k_1 = 2$, $k_2 = 3$, $\lambda = 174 \text{ pm}$

we get $d = 281 \text{ pm} = 2.81 \text{ \AA}$

(and not 0.281 pm as given in the book.)

(Lattice parameters are typically in \AA 's and not in fractions of a pm.)

5.156 In a polycrystalline specimen, microcrystals are oriented at various angles with respect to one another. The microcrystals which are oriented at certain special angles with respect to the incident beam produce diffraction maxima that appear as rings.

The radial of these rings are given by

$$r = l \tan 2\alpha$$

where the Bragg's law gives

$$2d \sin \alpha = k\lambda$$

In our case $k = 2$, $d = 155 \text{ pm}$, $\lambda = 17.8 \text{ pm}$

so $\alpha = \sin^{-1} \frac{17.8}{155} = 6.6^\circ$ and $r = 3.52 \text{ cm}$.

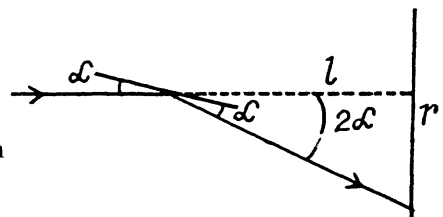

5.4 POLARIZATION OF LIGHT

5.157 Natural light can be considered to be an incoherent mixture of two plane polarized light of intensity $I_0 / 2$ with mutually perpendicular planes of vibration. The screen consisting of the two polaroid half-planes acts as an opaque half-screen for one or the other of these light waves. The resulting diffraction pattern has the alterations in intensity (in the illuminated region) characteristic of a straight edge on both sides of the boundary.

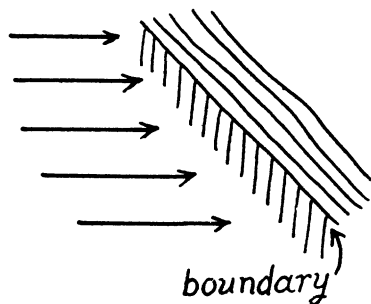

At the boundary the intensity due to either component is

$$\frac{(I_0 / 2)}{4}$$

and the total intensity is $\frac{I_0}{4}$. (Recall that when light of intensity I_0 is incident on a straight edge, the illuminance in front of the edge is $I_0 / 4$).

5.158 (a) Assume first that there is no polaroid and the amplitude due to the entire hole which extends over the first Fresnel zone is A_1

Then, we know, as usual, $I_0 = \frac{A_1^2}{4}$,

When the polaroid is introduced as shown above, each half transmits only the corresponding polarized light. If the full hole were covered by one polaroid the amplitude transmitted will be $(A_1 / \sqrt{2})$.

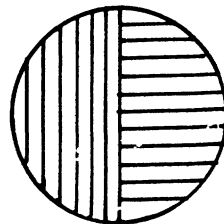

Therefore the amplitude transmitted in the present case will be $\frac{A_1}{2\sqrt{2}}$ through either half.

Since these transmitted waves are polarized in mutually perpendicular planes, the total intensity will be

$$\left(\frac{A_1}{2\sqrt{2}}\right)^2 + \left(\frac{A_1}{2\sqrt{2}}\right)^2 = \frac{A_1^2}{4} = I_0.$$

(b) We interpret the problem to mean that the two polaroid pieces are separated along the circumference of the circle limiting the first half of the Fresnel zone. (This however is inconsistent with the polaroids being identical in shape; however no other interpretation makes sense.)

From (5.103) and the previous problems we see that the amplitudes of the waves transmitted through the two parts is

$$\frac{A_1}{2\sqrt{2}}(1+i) \text{ and } \frac{A_1}{2\sqrt{2}}(1-i)$$

and the intensity is

$$\begin{aligned} & \left| \frac{A_1^2}{2\sqrt{2}}(1+i) \right|^2 + \left| \frac{A_1^2}{2\sqrt{2}}(1-i) \right|^2 \\ &= \frac{A_1^2}{2} = 2I_0 \end{aligned}$$

5.159 When the polarizer rotates with angular velocity ω its instantaneous principal direction makes angle ωt from a reference direction which we choose to be along the direction of vibration of the plane polarized incident light. The transmitted flux at this instant is

$$\Phi_0 \cos^2 \omega t$$

and the total energy passing through the polarizer per revolution is

$$\begin{aligned} & \int_0^T \Phi_0 \cos^2 \omega t dt, \quad T = 2\pi/\omega \\ &= \Phi_0 \frac{\pi}{\omega} = 0.6 \text{ m J.} \end{aligned}$$

5.160 Let I_0 = intensity of the incident beam.

Then the intensity of the beam transmitted through the first Nicol prism is

$$I_1 = \frac{1}{2} I_0$$

and through the 2nd prism is

$$I_2 = \left(\frac{1}{2} I_0 \right) \cos^2 \varphi$$

Through the N^{th} prism it will be

$$\begin{aligned} I_N &= I_{N-1} \cos^2 \varphi \\ &= \frac{1}{2} I_0 \cos^{2(N-1)} \varphi \end{aligned}$$

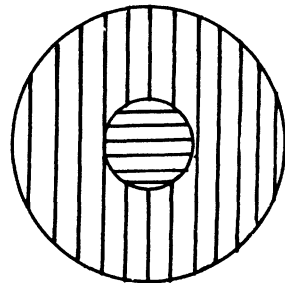

Hence fraction transmitted

$$= \frac{I_N}{I_0} = \eta = \frac{1}{2} \cos^{2(N-1)} \varphi = 0.12 \text{ for } N = 6.$$

and

$$\varphi = 30^\circ$$

5.161 When natural light is incident on the first polaroid, the fraction transmitted will be $\frac{1}{2} \tau$ (only the component polarized parallel to the principal direction of the polaroid will go).

The emergent light will be plane polarized and on passing through the second polaroid will be polarized in a different direction (corresponding to the principal direction of the 2nd polaroid) and the intensity will have decreased further by $\tau \cos^2 \varphi$.

In the third polaroid the direction of polarization will again have to change by φ thus only a fraction $\tau \cos^2 \varphi$ will go through.

Finally
$$I = I_0 \times \frac{1}{2} \tau^3 \cos^4 \varphi$$

Thus the intensity will have decreased

$$\frac{I_0}{I} = \frac{2}{\tau^3 \cos^4 \varphi} = 60.2 \text{ times}$$

for

$$\tau = 0.81, \quad \varphi = 60^\circ.$$

5.162 Suppose the partially polarized light consists of natural light of intensity I_1 and plane polarized light of intensity I_2 with direction of vibration parallel to, say, x - axis.

Then when a polaroid is used to transmit it, the light transmitted will have a maximum intensity

$$\frac{1}{2} I_1 + I_2,$$

when the principal direction of the polaroid is parallel to x - axis, and will have a minimum intensity $\frac{1}{2} I_1$ when the principal direction is \perp to x - axis.

Thus
$$P = \frac{I_{\max} - I_{\min}}{I_{\max} + I_{\min}} = \frac{I_2}{I_1 + I_2}$$

so
$$\frac{I_2}{I_1} = \frac{P}{1 - P} = \frac{0.25}{0.75} = \frac{1}{3}.$$

5.163 If, as above,

I_1 = intensity of natural component

I_2 = intensity of plane polarized component

then
$$I_{\max} = \frac{1}{2} I_1 + I_2$$

and
$$I = \frac{I_{\max}}{\eta} = \frac{1}{2} I_1 + I_2 \cos^2 \varphi$$

so
$$I_2 = I_{\max} \left(1 - \frac{1}{\eta} \right) \operatorname{cosec}^2 \varphi$$

$$I_1 = 2 I_{\max} \left[1 - \left(1 - \frac{1}{\eta} \right) \operatorname{cosec}^2 \varphi \right] = \frac{2 I_{\max}}{\sin^2 \varphi} \left[\frac{1}{\eta} - \cos^2 \varphi \right]$$

Then
$$P = \frac{I_2}{I_1 + I_2} = \frac{1 - \frac{1}{\eta}}{2 \left(\frac{1}{\eta} - \cos^2 \varphi \right) + 1 - \frac{1}{\eta}} = \frac{\eta - 1}{1 - \eta \cos 2 \varphi}$$

On putting

$$\eta = 3.0, \quad \varphi = 60^\circ$$

we get

$$P = \frac{2}{1 + 3 \times \frac{1}{2}} = \frac{4}{5} = 0.8$$

5.164 Let us represent the natural light as a sum of two mutually perpendicular components, both with intensity I_0 . Suppose that each polarizer transmits a fraction α_1 of the light with oscillation plane parallel to the principal direction of the polarizer and a fraction α_2 with oscillation plane perpendicular to the principal direction of the polarizer. Then the intensity of light transmitted through the two polarizers is equal to

$$I_{\parallel} = \alpha_1^2 I_0 + \alpha_2^2 I_0$$

when their principal direction are parallel and

$$I_{\perp} = \alpha_1 \alpha_2 I_0 + \alpha_2 \alpha_1 I_0 = 2 \alpha_1 \alpha_2 I_0$$

when they are crossed. But

$$\frac{I_{\perp}}{I_{\parallel}} = \frac{2 \alpha_1 \alpha_2}{\alpha_1^2 + \alpha_2^2} = \frac{1}{\eta}$$

so

$$\frac{\alpha_1 - \alpha_2}{\alpha_1 + \alpha_2} = \sqrt{\frac{\eta - 1}{\eta + 1}}$$

(a) Now the degree of polarization produced by either polarizer when used singly is

$$P_0 = \frac{I_{\max} - I_{\min}}{I_{\max} + I_{\min}} = \frac{\alpha_1 - \alpha_2}{\alpha_1 + \alpha_2}$$

(assuming, of course, $\alpha_1 > \alpha_2$)

Thus

$$P_0 = \sqrt{\frac{\eta - 1}{\eta + 1}} = \sqrt{\frac{9}{11}} = 0.905$$

(b) When both polarizer are used with their principal directions parallel, the transmitted light, when analysed, has

maximum intensity, $I_{\max} = \alpha_1^2 I_0$ and minimum intensity, $I_{\min} = \alpha_2^2 I_0$

so

$$\begin{aligned} P &= \frac{\alpha_1^2 - \alpha_2^2}{\alpha_1^2 + \alpha_2^2} = \frac{\alpha_1 - \alpha_2}{\alpha_1 + \alpha_2} \cdot \frac{(\alpha_1 + \alpha_2)^2}{\alpha_1^2 + \alpha_2^2} \\ &= \sqrt{\frac{\eta - 1}{\eta + 1}} \cdot \left(1 + \frac{2 \alpha_1 \alpha_2}{\alpha_1^2 + \alpha_2^2} \right) \\ &= \sqrt{\frac{\eta - 1}{\eta + 1}} \left(1 + \frac{1}{\eta} \right) = \frac{\sqrt{\eta^2 - 1}}{\eta} = \sqrt{1 - \frac{1}{\eta^2}} = 0.995. \end{aligned}$$

5.165 If the principal direction N of the Nicol is along A or B , the intensity of light transmitted is the same whether the light incident is one with oscillation plane N_1 or one with N_2 . If N makes an angle $\delta\varphi$ with A as shown then the fractional difference in intensity transmitted (when the light incident is N_1 or N_2) is

$$\begin{aligned} \left(\frac{\Delta I}{I}\right)_A &= \frac{\cos^2\left(90^\circ - \frac{\varphi}{2} - \delta\varphi\right) - \cos^2\left(90^\circ + \frac{\varphi}{2} - \delta\varphi\right)}{\cos^2\left(90^\circ - \frac{\varphi}{2}\right)} \\ &= \frac{\sin^2\left(\frac{\varphi}{2} + \delta\varphi\right) - \sin^2\left(\frac{\varphi}{2} - \delta\varphi\right)}{\sin^2\frac{\varphi}{2}} \\ &= \frac{2\sin\frac{\varphi}{2} \cdot 2\cos\frac{\varphi}{2}\delta\varphi}{\sin^2\frac{\varphi}{2}} = 4\cot\frac{\varphi}{2}\delta\varphi \end{aligned}$$

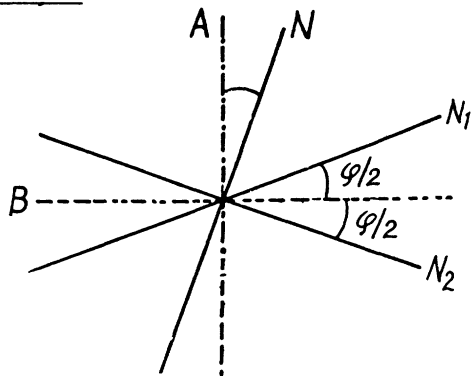

If N makes an angle $\delta\varphi$ ($\ll \varphi$) with B then

$$\left(\frac{\Delta I}{I}\right)_B = \frac{\cos^2(\varphi/2 - \delta\varphi) - \cos^2(\varphi/2 + \delta\varphi)}{\cos^2\varphi/2} = \frac{2\cos\frac{\varphi}{2} \cdot 2\sin\varphi/2\delta\varphi}{\cos^2\varphi/2} = 4\tan\varphi/2\delta\varphi$$

Thus
$$\eta = \left(\frac{\Delta I}{I}\right)_A / \left(\frac{\Delta I}{I}\right)_B = \cot^2\varphi/2$$

or
$$\varphi = 2\tan^{-1}\frac{1}{\sqrt{\eta}}$$

This gives $\varphi = 11.4^\circ$ for $\eta = 100$.

5.166 Fresnel equations read

$$I_{\perp} = I_{\perp} \frac{\sin^2(\theta_1 - \theta_2)}{\sin^2(\theta_1 + \theta_2)} \quad \text{and} \quad I_{\parallel} = I_{\parallel} \frac{\tan^2(\theta_1 - \theta_2)}{\tan^2(\theta_1 + \theta_2)}$$

At the boundary between vacuum and a dielectric $\theta_1 \neq \theta_2$ since by Snell's law

$$\sin\theta_1 = n\sin\theta_2$$

Thus I_{\perp}/I_{\perp} cannot be zero. However, if $\theta_1 + \theta_2 = 90^\circ$, $I_{\parallel} = 0$ and the reflected light is polarized in this case. The condition for this is

$$\sin\theta_1 = n\sin\theta_2, \quad = n\sin(90^\circ - \theta_1)$$

or
$$\tan\theta_1 = n \quad \theta_1 \text{ is called Brewsta's angle.}$$

The angle between reflected light and refracted light is 90° in this case.

5.167 (a) From Fresnel's equations

$$\left. \begin{aligned} I'_{\perp} &= I_{\perp} \frac{\sin^2(\theta_1 - \theta_2)}{\sin^2(\theta_1 + \theta_2)} \\ I'_{\parallel} &= 0 \end{aligned} \right\} \text{ at Brewste's angle}$$

$$I'_{\perp} = I_{\perp} \sin^2(\theta_1 - \theta_2)$$

$$= \frac{1}{2} I (\sin \theta_1 \cos \theta_2 - \cos \theta_1 \sin \theta_2)^2$$

Now

$$\tan \theta_1 = n, \quad \sin \theta_1 = \frac{n}{\sqrt{n^2 + 1}}$$

$$\cos \theta_1 = \frac{1}{\sqrt{n^2 + 1}}, \quad \sin \theta_2 = \cos \theta_1$$

$$\cos \theta_2 = \sin \theta_1$$

$$I'_{\perp} = \frac{1}{2} I \left(\frac{n^2 - 1}{n^2 + 1} \right)^2$$

Thus reflection coefficient = $\rho = \frac{I'_{\perp}}{I}$

$$= \frac{1}{2} \left(\frac{n^2 - 1}{n^2 + 1} \right)^2 = 0.074$$

on putting $n = 1.5$

(b) For the refracted light

$$I''_{\perp} = I_{\perp} - I'_{\perp} = \frac{1}{2} I \left\{ 1 - \left(\frac{n^2 - 1}{n^2 + 1} \right)^2 \right\}$$

$$= \frac{1}{2} I \frac{4n^2}{(n^2 + 1)^2}$$

$$I''_{\parallel} = \frac{1}{2} I$$

at the Brewster's angle.

Thus the degree of polarization of the refracted light is

$$P = \frac{I''_{\parallel} - I''_{\perp}}{I''_{\parallel} + I''_{\perp}} = \frac{(n^2 + 1)^2 - 4n^2}{(n^2 + 1)^2 + 4n^2}$$

$$= \frac{(n^2 - 1)^2}{2(n^2 + 1)^2 - (n^2 - 1)^2} = \frac{\rho}{1 - \rho}$$

On putting $\rho = 0.074$ we get $P = 0.080$.

5.168 The energy transmitted is, by conservation of energy, the difference between incident energy and the reflected energy. However the intensity is affected by the change of the cross section of the beam by refraction. Let A_i , A_r , A_t be the cross sections of the incident, reflected and transmitted beams. Then

$$A_i = A_r$$

$$A_t = A_i \frac{\cos r}{\cos i}$$

But at Brewster's angle $r = 90 - i$

so

$$A_r = A_i \tan i = n A_i$$

Thus

$$I_t = \frac{(1 - \rho) I_0}{n}$$

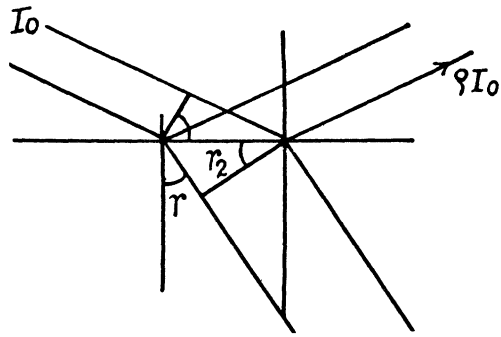

5.169 The amplitude of the incident component whose oscillation vector is perpendicular to the plane of incidence is

$$A_{\perp} = A_0 \sin \varphi$$

and similarly

$$A_{\parallel} = A_0 \cos \varphi$$

Then

$$\begin{aligned} I'_{\perp} &= I_0 \frac{\sin^2 (\theta_1 - \theta_2)}{\sin^2 (\theta_1 + \theta_2)} \sin^2 \varphi \\ &= I_0 \left[\frac{\sin \theta_1 \cos \theta_2 - \cos \theta_1 \sin \theta_2}{\sin \theta_1 \cos \theta_2 + \cos \theta_1 \sin \theta_2} \right]^2 \sin^2 \varphi \\ &= I_0 \left[\frac{n^2 - 1}{n^2 + 1} \right]^2 \sin^2 \varphi \end{aligned}$$

Hence

$$\rho = \frac{I'_{\perp}}{I_0} = \left[\frac{n^2 - 1}{n^2 + 1} \right]^2 \sin^2 \varphi$$

Putting $n = 1.33$ for water we get $\rho = 0.0386$

5.170 Since natural light is incident at the Brewster's angle, the reflected light 1 is completely polarized and $P_1 = 1$.

Similarly the ray 2 is incident on glass air surface at Brewster's angle $\left(\tan^{-1} \frac{1}{n} \right)$ so 3 is also completely polarized. Thus $P_3 = 1$

Now as in 5.167 (b)

$$P_2 = \frac{\rho}{1 - \rho} = 0.087 \text{ if } \rho = 0.080$$

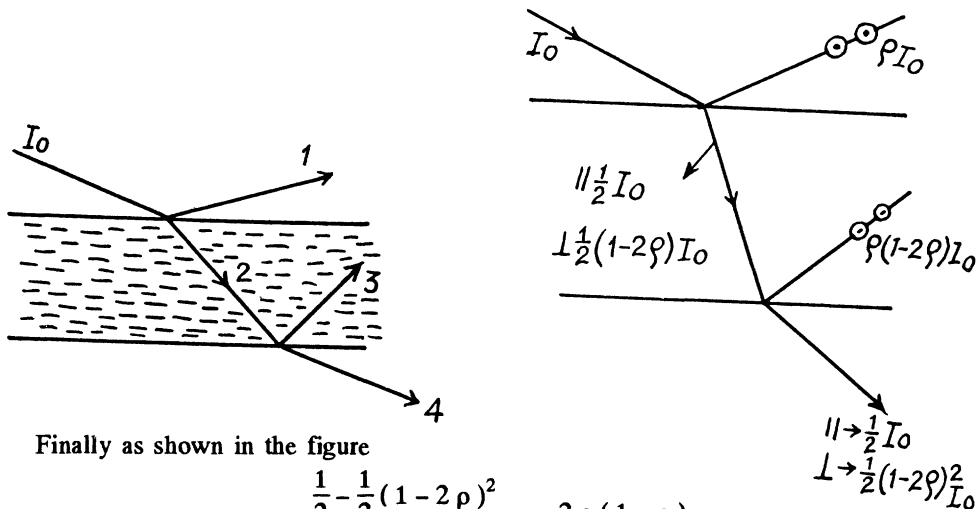

Finally as shown in the figure

$$P_4 = \frac{\frac{1}{2} - \frac{1}{2}(1-2\rho)^2}{\frac{1}{2} + \frac{1}{2}(1-2\rho)^2} = \frac{2\rho(1-\rho)}{1-2\rho(1-\rho)} = 0.173$$

5.171 (a) In this case from Fresnel's equations

$$r'_1 = I_1 \frac{\sin^2(\theta_1 - \theta_2)}{\sin^2(\theta_1 + \theta_2)}$$

we get

$$I_1 = \left(\frac{n^2 - 1}{n^2 + 1} \right)^2 I_0 = \rho I_0 \text{ say}$$

then

$$I_2 = (1 - \rho)I_0, I_3 = \rho(1 - \rho)I_0$$

(ρ is invariant under the substitution $n \rightarrow \frac{1}{n}$)

finally

$$I_4 = (1 - \rho)^2 I_0 = \frac{16n^4}{(n^2 + 1)^4} I_0 = 0.726 I_0.$$

(b) Suppose ρ' = coefficient of reflection for the component of light whose electric vector oscillates at right angles to the incidence plane.

From Fresnel's equations

$$\rho' = \left(\frac{n^2 - 1}{n^2 + 1} \right)^2$$

Then in the transmitted beam we have a partially polarized beam which is a superposition of two (\parallel & \perp) components with intensities

$$\frac{1}{2} I_0 \text{ \& \ } \frac{1}{2} I_0 (1 - \rho')^2$$

Thus

$$P = \frac{1 - (1 - \rho')^2}{1 + (1 - \rho')^2} = \frac{(n^2 + 1)^4 - 16n^4}{(n^2 + 1)^4 + 16n^4} = \frac{1 - 0.726}{1 + 0.726} = 0.158$$

- 5.172 (a) When natural light is incident on a glass plate at Brewster's angle, the transmitted light has

$$I_{||}' = I_0/2 \text{ and } I_{\perp}' = \frac{16n^4}{(n^2+1)^4} I_0/2 = \alpha^4 I_0/2$$

where I_0 is the incident intensity (see 5.171 a)

After passing through the 2nd plate we find

$$I_{||}'' = \frac{1}{2} I_0 \text{ and } I_{\perp}'' = (\alpha^4)^2 \frac{1}{2} I_0$$

Thus after N plates

$$I_{||}^{trans} = \frac{1}{2} I_0$$

$$I_{\perp}^{trans} = \alpha^{4N} \frac{1}{2} I_0$$

Hence

$$P = \frac{1 - \alpha^{4N}}{1 + \alpha^{4N}} \text{ where } \alpha = \frac{2n}{1+n^2}$$

- (b) $\alpha^4 = 0.726$ for $n = \frac{3}{2}$.

Thus

$$P(N = 1) = 0.158, P(N = 2) = 0.310$$

$$P(N = 5) = 0.663, P(N = 10) = 0.922.$$

- 5.173 (a) We decompose the natural light into two components with intensity $I_{||} = \frac{1}{2} I_0 = I_{\perp}$ where $||$ has its electric vector oscillating parallel to the plane of incidence and \perp has the same \perp^r to it.

By Fresnel's equations for normal incidence

$$\frac{I_{\perp}'}{I_{\perp}} = \lim_{\theta_1 \rightarrow 0} \frac{\sin^2(\theta_1 - \theta_2)}{\sin^2(\theta_1 + \theta_2)} = \lim_{\theta_1 \rightarrow 0} \left(\frac{\theta_1 - \theta_2}{\theta_1 + \theta_2} \right)^2 = \left(\frac{n-1}{n+1} \right)^2 = \rho$$

similarly
$$\frac{I_{||}'}{I_{||}} = \rho = \left(\frac{n-1}{n+1} \right)^2$$

Thus
$$\frac{I'}{I} = \rho = \left(\frac{0.5}{2.5} \right)^2 = \frac{1}{25} = 0.04$$

- (b) The reflected light at the first surface has the intensity

$$I_1 = \rho I_0$$

Then the transmitted light has the intensity

$$I_2 = (1 - \rho) I_0$$

At the second surface where light emerges from glass into air, the reflection coefficient is again ρ because

ρ is invariant under the substitution $n \rightarrow \frac{1}{n}$.

Thus $I_3 = \rho(1 - \rho) I_0$ and $I_4 = (1 - \rho)^2 I_0$.

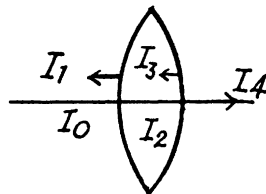

For N lenses the loss in luminous flux is then

$$\frac{\Delta \Phi}{\Phi} = 1 - (1 - \rho)^{2N} = 0.335 \text{ for } N = 5$$

5.174 Suppose the incident light can be decomposed into waves with intensity $I_{||}$ & I_{\perp} with oscillations of the electric vectors parallel and perpendicular to the plane of incidence.

For normal incidence we have from Fresnel equations

$$I'_{\perp} = I_{\perp} \left(\frac{\theta_1 - \theta_2}{\theta_1 + \theta_2} \right)^2 \rightarrow I_{\perp} \left(\frac{n-1}{n+1} \right)^2$$

where we have used $\sin \theta \approx \theta$ for small θ .

Similarly

$$I'_{||} = I_{||} \left(\frac{n'-1}{n'+1} \right)^2$$

Then the refracted wave will be

$$I''_{||} = I_{||} \frac{4n'}{(n'+1)^2} \text{ and } I''_{\perp} = I_{\perp} \frac{4n'}{(n'+1)^2}$$

At the interface with glass

$$I'''_{\perp} = I''_{\perp} \left(\frac{n'-n}{n'+n} \right)^2, \text{ similarly for } I'''_{||}$$

we see that

$$\frac{I'_{\perp}}{I_{\perp}} = \frac{I'''_{\perp}}{I''_{\perp}} \text{ if } n' = \sqrt{n}, \text{ similarly for } || \text{ component.}$$

This shows that the light reflected as a fraction of the incident light is the same on the two surfaces if $n' = \sqrt{n}$.

Note:- The statement of the problem given in the book is incorrect. Actual amplitudes are not equal; only the reflectance is equal.

5.175 Here $\theta_1 = 45^\circ$

$$\sin \theta_2 = \frac{1}{\sqrt{2}} \times \frac{1}{n} = \frac{2}{3\sqrt{2}} = \frac{\sqrt{2}}{3} = 0.4714$$

$$\theta_2 = \sin^{-1} 0.4714 = 28.1^\circ$$

Hence

$$\begin{aligned} I'_{\perp} &= I_{\perp} \frac{\sin^2(\theta_1 - \theta_2)}{\sin^2(\theta_1 + \theta_2)} \\ &= \frac{1}{2} I_0 \left(\frac{\sin 16.9^\circ}{\sin 73.1^\circ} \right)^2 = \frac{1}{2} I_0 \times 0.0923 \end{aligned}$$

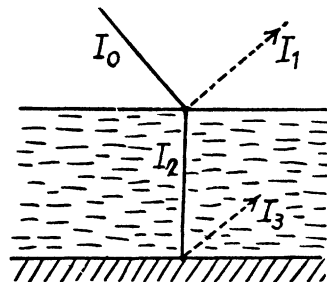

$$I_{||}' = \frac{1}{2} I_0 \left(\frac{\tan 16.9}{\tan 73.1} \right)^2 = \frac{1}{2} I_0 \times 0.0085$$

Thus

(a) Degree of polarization P of the reflected light

$$= \frac{0.0838}{0.1008} = 0.831$$

(b) By conservation of energy

$$I_{\perp}'' = \frac{1}{2} I_0 \times 0.9077$$

$$I_{||}'' = \frac{1}{2} I_0 \times 0.9915$$

Thus

$$P = \frac{0.0838}{1.8982} = 0.044$$

5.176 The wave surface of a uniaxial crystal consists of two sheets of which one is a sphere while the other is an ellipsoid of revolution.

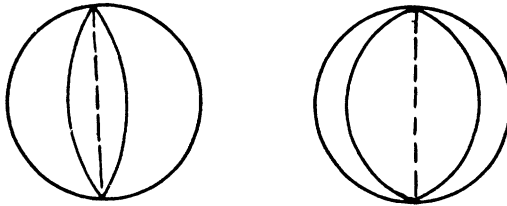

The optic axis is the line joining the points of contact.

To make the appropriate Huygen's construction we must draw the relevant section of the wave surface inside the crystal and determine the directions of the ordinary and extraordinary rays. The result is as shown in Fig. 42 (a, b & c) of the answers

5.177 In a uniaxial crystal, an unpolarized beam of light (or even a polarized one) splits up into O (for ordinary) and E (for extraordinary) light waves. The direction of vibration in the O and E waves are most easily specified in terms of the O and E principal planes. The principal plane of the ordinary wave is defined as the plane containing the O ray and the optic axis. Similarly the principal plane of the E wave is the plane containing the E ray and the optic axis. In terms of these planes the following is true : The O vibrations are perpendicular to the principal plane of the O ray while the E vibrations are in the principal plane of the E ray.

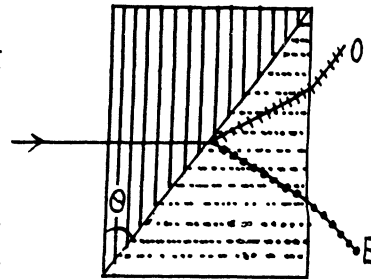

When we apply this definition to the wollaston prism we find the following :

(exaggerated.)

When unpolarized light enters from the left the O and E waves travel in the same direction but with different speeds. The O ray on the left has its vibrations normal to the plane of the paper and it becomes E ray on crossing the diagonal boundary of the two prism similarly the E ray on the left becomes O ray on the right. In this case Snell's law is applicable only approximately. The two rays are incident on the boundary at an angle θ and in the right prism the ray which we have called O ray on the right emerges at

$$\sin^{-1} \frac{n_e}{n_0} \sin \theta = \sin^{-1} \frac{1.658}{1.486} \times \frac{1}{2} = 33.91^\circ$$

where we have used

$$n_e = 1.1658, n_0 = 1.486 \text{ and } \theta = 30^\circ.$$

Similarly the E ray on the right emerges within the prism at

$$\sin^{-1} \frac{n_0}{n_e} \sin \theta = 26.62^\circ$$

This means that the O ray is incident at the boundary between the prism and air at

$$33.91 - 30^\circ = 3.91^\circ$$

and will emerge into air with a deviation of

$$\begin{aligned} \sin^{-1} n_0 \sin 3.91^\circ \\ = \sin^{-1} (1.658 \sin 3.91^\circ) = 6.49^\circ \end{aligned}$$

The E ray will emerge with an opposite deviation of

$$\begin{aligned} \sin^{-1} (n_e \sin (30^\circ - 26.62^\circ)) \\ = \sin^{-1} (1.486 \sin 3.38^\circ) = 5.03^\circ \end{aligned}$$

Hence

$$\delta \approx 6.49^\circ + 5.03^\circ = 11.52^\circ$$

This result is accurate to first order in $(n_e - n_0)$ because Snell's law holds when $n_e = n_0$.

5.178 The wave is moving in the direction of z - axis

(a) Here $E_x = E \cos(\omega t - kz)$, $E_y = E \sin(\omega t - kz)$

$$\frac{E_x^2}{E^2} + \frac{E_y^2}{E^2} = 1$$

so the tip of the electric vector moves along a circle. For the right handed coordinate system this represents circular anticlockwise polarization when observed towards the incoming wave.

(b) $E_x = E \cos(\omega t - kz)$, $E_y = E \cos\left(\omega t - kz + \frac{\pi}{4}\right)$

$$\text{so } \frac{E_y}{E} = \frac{1}{\sqrt{2}} \cos(\omega t - kz) - \frac{1}{\sqrt{2}} \sin(\omega t - kz)$$

$$\text{or } \left(\frac{E_y}{E} - \frac{1}{\sqrt{2}} \frac{E_x}{E}\right)^2 = \frac{1}{2} \left(1 - \frac{E_x^2}{E^2}\right)$$

$$\text{or } \frac{E_y^2}{E^2} + \frac{E_x^2}{E^2} - \sqrt{2} \frac{E_y E_x}{E^2} = \frac{1}{2}$$

This is clearly an ellipse. By comparing with the previous case (compare the phase of E_y in the two cases) we see this represents elliptical clockwise polarization when viewed towards the incoming wave.

We write the equations as

$$E_x + E_y = 2E \cos \left(\omega t - kz + \frac{\pi}{8} \right) \cos \frac{\pi}{8}$$

$$E_x - E_y = +2E \sin \left(\omega t - kz + \frac{\pi}{8} \right) \sin \frac{\pi}{8}$$

Thus

$$\left(\frac{E_x + E_y}{2E \cos \frac{\pi}{8}} \right)^2 + \left(\frac{E_x - E_y}{2E \sin \frac{\pi}{8}} \right)^2 = 1$$

Since $\cos \frac{\pi}{8} > \sin \frac{\pi}{8}$, the major axis is in the direction of the straight line $y = x$.

(c) $E_x = E \cos (\omega t - kz)$

$$E_y = E \cos (\omega t - kz + \pi) = -E \cos (\omega t - kz)$$

Thus the top of the electric vector traces the curve

$$E_y = -E_x$$

which is a straight line ($y = -x$). It corresponds to plane polarization.

5.179 For quartz

$$\left. \begin{array}{l} n_e = 1.553 \\ n_o = 1.544 \end{array} \right\} \text{ for } \lambda = 589 \text{ nm.}$$

In a quartz plate cut parallel to its optic axis, plane polarized light incident normally from the left divides itself into O and E waves which move in the same direction with different speeds and as a result acquire a phase difference. This phase difference is

$$\delta = \frac{2\pi}{\lambda} (n_e - n_o) d$$

where d = thickness of the plate. In general this makes the emergent light elliptically polarized.

(a) For emergent light to experience only rotation of polarization plane

$$\delta = (2k + 1)\pi, \quad k = 0, 1, 2, 3 \dots$$

$$\text{For this } d = (2k + 1) \frac{\lambda}{2(n_e - n_o)}$$

$$= (2k + 1) \frac{.589}{2 \times .009} \mu\text{m} = (2k + 1) \frac{.589}{18} \text{ mm}$$

The maximum value of $(2k + 1)$ for which this is less than 0.50 is obtained from

$$\frac{0.50 \times 18}{0.589} = 15.28$$

Then we must take $k = 7$ and $d = 15 \times \frac{.589}{18} = 0.4908 \text{ mm}$

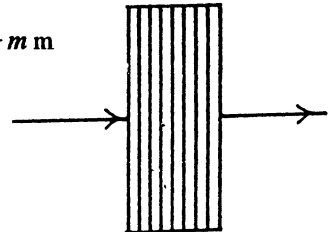

(b) For circular polarization $\delta = \frac{\pi}{2}$

modulo 2π i.e. $\delta = (4k+1)\frac{\pi}{2}$

so $d = (4k+1)\frac{\lambda}{4(n_e - n_o)} = (4k+1)\frac{0.589}{36}$

Now $\frac{0.50 \times 36}{0.589} = 30.56$

The nearest integer less than this which is of the form $4k+1$ is 29 for $k=7$. For this $d = 0.4749$ mm

5.180 As in the previous problem the quartz plate introduces a phase difference δ between the O & E components. When $\delta = \pi/2$ (modulo π) the resultant wave is circularly polarized. In this case intensity is independent of the rotation of the rear prism. Now

$$\begin{aligned}\delta &= \frac{2\pi}{\lambda} (n_e - n_o) d \\ &= \frac{2\pi}{\lambda} 0.009 \times 0.5 \times 10^{-3} \text{ m} \\ &= \frac{9\pi}{\lambda}, \lambda \text{ in } \mu\text{m}\end{aligned}$$

For $\lambda = 0.50 \mu\text{m}$. $\delta = 18\pi$. The relevant values of δ have to be chosen in the form

$$\left(k + \frac{1}{2}\right)\pi. \text{ For } k = 17, 16, 15 \text{ we get}$$

$$\lambda = 0.5143 \mu\text{m}, 0.5435 \mu\text{m} \text{ and } 0.5806 \mu\text{m}$$

These are the values of λ which lie between $0.50 \mu\text{m}$ and $0.60 \mu\text{m}$.

5.181 As in the previous two problems the quartz plate will introduce a phase difference δ . The light on passing through the plate will remain plane polarized only for $\delta = 2k\pi$ or $(2k+1)\pi$. In the latter case the plane of polarization of the light incident on the plate will be rotated by 90° by it so light passing through the analyser (which was originally crossed) will be a **maximum**. Thus dark bands will be observed only for those λ for which

$$\delta = 2k\pi$$

$$\begin{aligned}\text{Now } \delta &= \frac{2\pi}{\lambda} (n_e - n_o) d = \frac{2\pi}{\lambda} \times 0.009 \times 1.5 \times 10^{-3} \text{ m} \\ &= \frac{27\pi}{\lambda} (\lambda \text{ in } \mu\text{m})\end{aligned}$$

For $\lambda = 0.55$ we get $\delta = 49.09\pi$

Choosing $\delta = 48\pi, 46\pi, 44\pi, 42\pi$ we get $\lambda = 0.5625 \mu\text{m}, \lambda = 0.5870 \mu\text{m}, \lambda = 0.6136 \mu\text{m}$ and $\lambda = 0.6429 \mu\text{m}$. These are the only values between $0.55 \mu\text{m}$ and $0.66 \mu\text{m}$. Thus there are four bands.

5.182 Here

$$\begin{aligned}\delta &= \frac{2\pi}{\lambda} \times 0.009 \times 0.25 \text{ m} \\ &= \frac{4.5\pi}{\lambda}, \lambda \text{ in } \mu\text{m}.\end{aligned}$$

We check that for

$$\lambda = 428.6 \text{ nm} \quad \delta = 10.5\pi$$

$$\lambda = 529.4 \text{ nm} \quad \delta = 8.5\pi$$

$$\lambda = 692.3 \text{ nm} \quad \delta = 6.5\pi$$

These are the only values of λ for which the plate acts as a quarter wave plate.

5.183 Between crossed Nicols, a quartz plate, whose optic axis makes 45° with the principal directions of the Nicols, must introduce a phase difference of $(2k+1)\pi$ so as to transmit the incident light (of that wavelength) with maximum intensity. For in this case the plane of polarization of the light emerging from the polarizer will be rotated by 90° and will go through the analyser undiminished. Thus we write for light of wavelengths 643 nm

$$\begin{aligned}\delta &= \frac{2\pi \times 0.009}{0.643 \times 10^{-6}} \times d \text{ (mm)} \times 10^{-3} \\ &= \frac{18\pi d}{0.643} = (2k+1)\pi\end{aligned}\quad (1)$$

To nearly block light of wavelength 564 nm we require

$$\frac{18\pi d}{0.564} = (2k')\pi\quad (2)$$

We must have $2k' > 2k+1$. For the smallest value of d we take $2k' = 2k+2$.

Thus

$$0.643(2k+1) = 0.564 \times (2k+2)$$

so

$$0.079 \times 2k = 0.564 \times 2 - 0.643$$

or

$$2k = 6.139$$

This is not quite an integer but is close to one. This means that if we take $2k = 6$ equations (1) can be satisfied exactly while equation (2) will hold approximately. Thus

$$d = \frac{7 \times 0.643}{18} = 0.250 \text{ mm}$$

5.184 If a ray traverses the wedge at a distance x below the joint, then the distance that the ray moves in the wedge is

$2x \tan \frac{\Theta}{2}$ and this cause a phase difference

$$\delta = \frac{2\pi}{\lambda} (n_e - n_o) 2x \tan \frac{\Theta}{2}$$

between the E and O wave components of the ray. For a general x the resulting light is elliptically polarized and is not completely quenched by the analyser polaroid. The condition for complete quenching is

$$\delta = 2k\pi \text{— dark fringe}$$

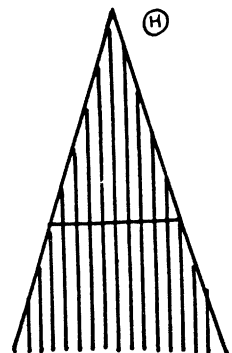

That for maximum brightness is

$$\delta = (2k + 1)\pi - \text{bright fringe.}$$

The fringe width is given by

$$\Delta x = \frac{\lambda}{2(n_e - n_o) \tan \frac{\Theta}{2}}$$

Hence

$$(n_e - n_o) = \frac{\lambda}{2 \Delta x \tan \Theta/2}$$

using

$$\tan(\Theta/2) = \tan 175^\circ = 0.03055,$$

$$\lambda = 0.55 \mu\text{m} \text{ and } \Delta x = 1 \text{ mm, we get}$$

$$n_e - n_o = 9.001 \times 10^{-3}$$

5.185 Light emerging from the first polaroid is plane polarized with amplitude A where N_1 is the principal direction of the polaroid and a vibration of amplitude can be resolved into two vibrations: E wave with vibration along the optic axis of amplitude $A \cos \varphi$ and the O wave with vibration perpendicular to the optic axis and having an amplitude $A \sin \varphi$. These acquire a phase difference δ on passing through the plate. The second polaroid transmits the components

$$A \cos \varphi \cos \varphi'$$

and

$$A \sin \varphi \sin \varphi'$$

What emerges from the second polaroid is a set of two plane polarized waves in the same direction and same plane of polarization but phase difference δ . They interfere and produce a wave of amplitude squared

$$R^2 = A^2 \left[\cos^2 \varphi \cos^2 \varphi' + \sin^2 \varphi \sin^2 \varphi' + 2 \cos \varphi \cos \varphi' \sin \varphi \sin \varphi' \cos \delta \right],$$

$$\text{using } \cos^2(\varphi - \varphi') = (\cos \varphi \cos \varphi' + \sin \varphi \sin \varphi')^2$$

$$= \cos^2 \varphi \cos^2 \varphi' + \sin^2 \varphi \sin^2 \varphi' + 2 \cos \varphi \cos \varphi' \sin \varphi \sin \varphi'$$

we easily find

$$R^2 = A^2 \left[\cos^2(\varphi - \varphi') - \sin 2\varphi \sin 2\varphi' \sin^2 \frac{\delta}{2} \right]$$

Now

$$A^2 = I_0/2 \text{ and } R^2 = I \text{ so the result is}$$

$$I = \frac{1}{2} I_0 \left[\cos^2(\varphi - \varphi') - \sin 2\varphi \sin 2\varphi' \sin^2 \frac{\delta}{2} \right]$$

Special cases :- Crossed polaroids : Here $\varphi - \varphi' = 90^\circ$ or $\varphi' = \varphi - 90^\circ$ and $2\varphi' = 2\varphi - 180^\circ$

Thus in this case

$$I = I_{\perp} = \frac{1}{2} I_0 \sin^2 2\varphi \sin^2 \frac{\delta}{2}$$

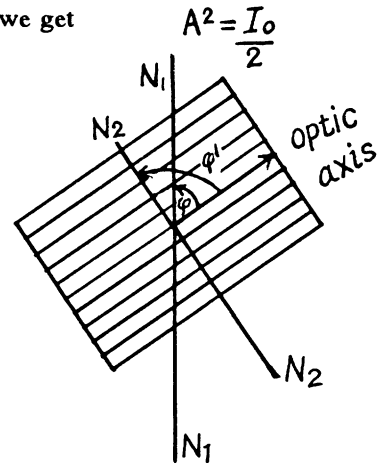

Parallel polaroids : Here $\varphi = \varphi'$ and

$$I = I_{||} = \frac{1}{2} I_0 \left(1 - \sin^2 2\varphi \sin^2 \frac{\delta}{2} \right)$$

With $\delta = \frac{2\pi}{\lambda} \Delta$, the conditions for the maximum and minimum are easily found to be that shown in the answer.

- 5.186** Let the circularly polarized light be resolved into plane polarized components of amplitude A_0 with a phase difference $\frac{\pi}{2}$ between them.

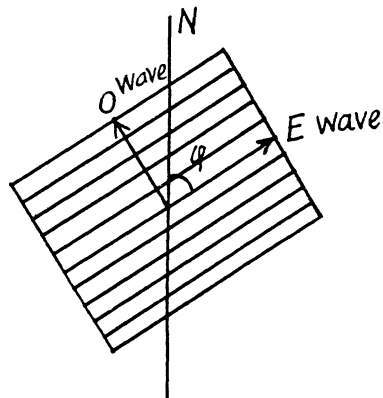

On passing through the crystal the phase difference becomes $\delta + \frac{\pi}{2}$ and the components of the E and O wave in the direction N are respectively $A_0 \cos \varphi$ and $A_0 \sin \varphi$

They interfere to produce the amplitude squared

$$\begin{aligned} R^2 &= A_0^2 \cos^2 \varphi + A_0^2 \sin^2 \varphi + 2A_0^2 \cos \varphi \sin \varphi \cos \left(\delta + \frac{\pi}{2} \right) \\ &= A_0^2 (1 + \sin 2\varphi \sin \delta) \end{aligned}$$

Hence $I = I_0 (1 + \sin 2\varphi \sin \delta)$

Here I_0 is the intensity of the light transmitted by the polaroid when there is no crystal plate.

- 5.187** (a) The light with right circular polarization (viewed against the oncoming light, this means that the light vector is moving clock wise.) becomes plane polarized on passing through a quarter-wave plate. In this case the direction of oscillations of the electric vector of the electromagnetic wave forms an angle of $+45^\circ$ with the axis of the crystal OO' (see Fig (a) below). In the case of left hand circular polarizations, this angle will be -45° (Fig (b)).

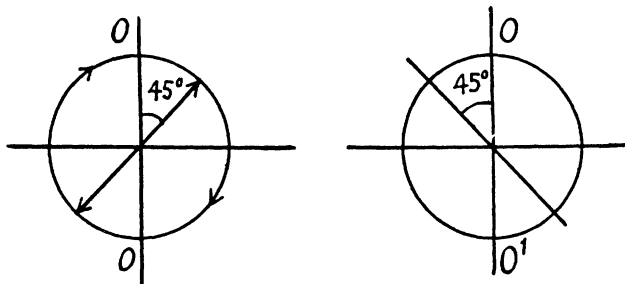

- (b) If for any position of the plate the rotation of the polaroid (located behind the plate) does not bring about any variation in the intensity of the transmitted light, the incident light

is unpolarized (i.e. natural). If the intensity of the transmitted light can drop to zero on rotating the analyzer polaroid for some position of the quarter wave plate, the incident light is circularly polarized. If it varies but does not drop to zero, it must be a mixture of natural and circularly polarized light.

5.188 The light from P is plane polarized with its electric vector vibrating at 45° with the plane of the paper. At first the sample S is absent. Light from P can be resolved into components vibrating in and perpendicular to the plane of the paper. The former is the E ray in the left half of the Babinet compensator and the latter is the O ray. In the right half the nomenclature is the opposite. In the compensator the two components acquire a phase difference which depends on the relative position of the ray. If the ray is incident at a distance x above the central line through the compensator then the E ray acquires a phase

$$\frac{2\pi}{\lambda} (n_E(l-x) + n_o(l+x)) \tan \Theta$$

while the O ray acquires

$$\frac{2\pi}{\lambda} (n_o(l-x) + n_E(l+x)) \tan \Theta$$

so the phase difference between the two rays is

$$\frac{2\pi}{\lambda} (n_o - n_E) 2x \tan \Theta = \delta$$

we get dark fringes when ever $\delta = 2k\pi$

because then the emergent light is the same as that coming from the polarizer and is quenched by the analyser. {If $\delta = (2k+1)\pi$, we get bright fringes because in this case, the plane of polarization of the emergent light has rotated by 90° and is therefore fully transmitted by the analyser.}

It follows that the fringe width Δx is given by

$$\Delta x = \frac{\lambda}{2 |n_o - n_E| \tan \Theta}$$

(b) If the fringes are displaced upwards by δx , then the path difference introduced by the sample between the O and the E rays must be such as to be exactly cancelled by the compensator. Thus

$$\frac{2\pi}{\lambda} [d(n'_o - n'_E) + (n_E - n_o) 2\delta x \tan \Theta] = 0$$

or

$$d(n'_o - n'_E) = -2(n_E - n_o) \delta x \tan \Theta$$

using $\tan \Theta \approx \Theta$.

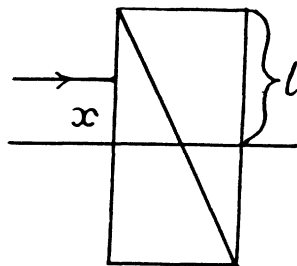
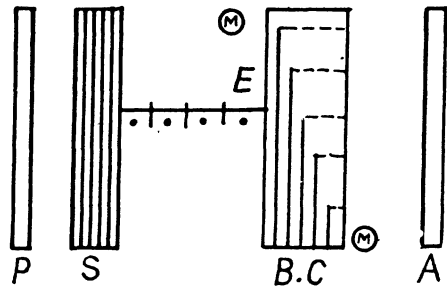

5.189 Light polarized along the x -direction (i.e. one whose electric vector has only an x component) and propagating along the z -direction can be decomposed into left and right circularly polarized light in accordance with the formula

$$E_x = \frac{1}{2}(E_x + iE_y) + \frac{1}{2}(E_x - iE_y)$$

On passing through a distance l of an active medium these acquire the phases $\delta_R = \frac{2\pi}{\lambda} n_R l$

and $\delta_L = \frac{2\pi}{\lambda} n_L l$ so we get for the complex amplitude

$$\begin{aligned} E' &= \frac{1}{2}(E_x + iE_y) e^{i\delta_R} + \frac{1}{2}(E_x - iE_y) e^{i\delta_L} \\ &= e^{i\frac{\delta_R + \delta_L}{2}} \left[\frac{1}{2}(E_x + iE_y) e^{i\delta/2} + \frac{1}{2}(E_x - iE_y) e^{-i\delta/2} \right] \\ &= e^{i\frac{\delta_R + \delta_L}{2}} \left[E_x \cos \frac{\delta}{2} - E_y \sin \frac{\delta}{2} \right], \quad \delta = \delta_R - \delta_L. \end{aligned}$$

Apart from an over all phase $(\delta_R + \delta_L)/2$ (which is irrelevant) this represents a wave whose plane of polarization has rotated by

$$\frac{\delta}{2} = \frac{\pi}{\lambda} (\Delta n) l, \quad \Delta n = |n_R - n_L|$$

By definition this equals αl so

$$\begin{aligned} \Delta n &= \frac{\alpha \lambda}{\pi} \\ &= \frac{589.5 \times 10^{-6} \text{ m} \times 21.72 \text{ deg/m} \times \pi}{\pi} \times \frac{\pi}{180} \text{ (rad)} \\ &= \frac{.5895 \times 21.72}{180} \times 10^{-3} \\ &= 0.71 \times 10^{-4} \end{aligned}$$

5.190 Plane polarized light on entering the wedge decomposes into right and left circularly polarized light which travel with different speeds in P and the emergent light gets its plane of polarization rotated by an angle which depends on the distance travelled.

Given that Δx = fringe width

$\Delta x \tan \theta$ = difference in the path length traversed by two rays which form successive bright or dark fringes.

Thus
$$\frac{2\pi}{\lambda} |n_R - n_L| \Delta x \tan \theta = 2\pi$$

Thus
$$\alpha = \frac{\pi \Delta n}{\lambda} = \pi / \Delta x \tan \theta$$

$$= 20.8 \text{ ang deg/m m}$$

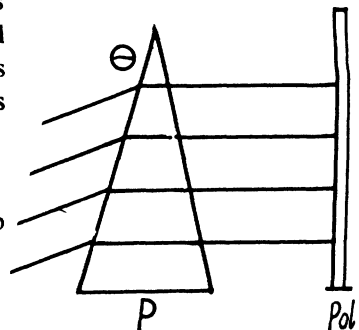

Let x = distance on the polaroid Pol as measured from a maximum. Then a ray that falls at this distance traverses an extra distance equal to

$$\pm x \tan \theta$$

and hence a rotation of $\pm \alpha x \tan \theta = \pm \frac{\pi x}{\Delta x}$

By Malus' law the intensity at this point will be $\sim \cos^2\left(\frac{\pi x}{\Delta x}\right)$.

5.191 If I_0 = intensity of natural light then

$\frac{1}{2}I_0$ = intensity of light emerging from the polarizer nicol.

Suppose the quartz plate rotates this light by φ , then the analyser will transmit

$$\begin{aligned} \frac{1}{2}I_0 \cos^2(90 - \varphi) \\ = \frac{1}{2}I_0 \sin^2 \varphi \end{aligned}$$

of this intensity. Hence

$$\eta I_0 = \frac{1}{2}I_0 \sin^2 \varphi$$

or

$$\varphi = \sin^{-1} \sqrt{2\eta}$$

But

$$\varphi = \alpha d \text{ so}$$

$$d_{\min} = \frac{1}{\alpha} \sin^{-1} \sqrt{2\eta}$$

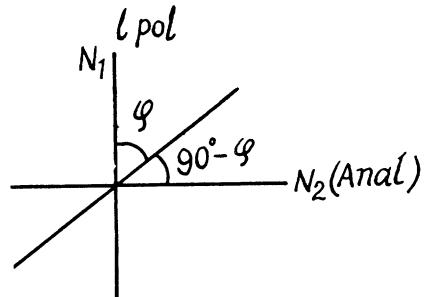

For minimum d we must take the principal value of inverse sine. Thus using $\alpha = 17 \text{ ang deg/m m}$.

$$d_{\min} = 2.99 \text{ m m}.$$

5.192 For light of wavelength 436 nm

$$41.5^\circ \times d = k \times 180^\circ = 2k \times 90^\circ$$

(Light will be completely cut off when the quartz plate rotates the plane of polarization by a multiple of 180° .) Here d = thickness of quartz plate in mm.

For natural incident light, half the light will be transmitted when the quartz rotates light by an odd multiple of 90° . Thus

$$31.1^\circ \times d = (2k' + 1) \times 90^\circ$$

Now

$$\frac{41.5}{31.1} = 1.3344 \approx \frac{4}{3}$$

Thus

$$k = 2 \text{ and } k' = 1 \text{ and}$$

$$d = \frac{4 \times 90}{41.5} = 8.67 \text{ m m}.$$

5.193 Two effects are involved here : rotation of plane of polarization by sugar solution and the effect of that rotation on the scattering of light in the transverse direction. The latter is shown in the figure given below. It is easy to see from the figure that there will be no scattering of light in this transverse direction if the incident light has its electric vector parallel to the line of sight. In such a situation, we expect fringes to occur in the given experiment.

From the given data we see that in a distance of 50 cm, the rotation of plane of polarization must be 180° . Thus the specific rotation constant of sugar

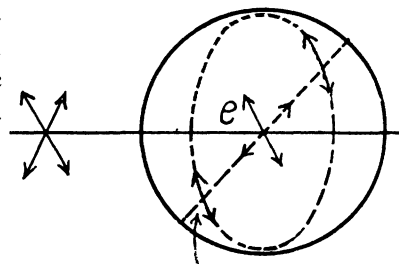

$$\begin{aligned}
 &= \frac{\text{rotation constant}}{\text{concentration}} \\
 &= \frac{180/50}{500 \frac{\text{g}}{\text{l}}} \text{ ang/deg/cm} = \frac{180}{5.0 \text{ dm} \times (.500 \text{ gm/cc})} \\
 &= 72^\circ \text{ ang deg}/(\text{dm} \cdot \text{gm/cc}) \quad (1 \text{ dm} = 10 \text{ cm})
 \end{aligned}$$

5.194 (a) in passing through the Kerr cell the two perpendicular components of the electric field will acquire a phase difference. When this phase difference equals 90° the emergent light will be circularly polarized because the two perpendicular components O & E have the same magnitude since it is given that the direction of electric field E in the capacitor forms an angle of 45° with the principal directions of the nicols. In this case the intensity of light that emerges from this system will be independent of the rotation of the analyser prism.

Now the phase difference introduced is given by

$$\delta = \frac{2\pi}{\lambda} (n_e - n_o) l$$

In the present case $\delta = \frac{\pi}{2}$ (for minimum electric field)

$$n_e - n_o = \frac{\lambda}{4l}$$

Now

$$n_e - n_o = B \lambda E^2$$

$$\text{so } E_{\min} = \sqrt{\frac{1}{4Bl}} = 10^5 / \sqrt{88} = 10.66 \text{ kV/cm}.$$

(b) If the applied electric field is

$$E = E_m \sin \omega t, \quad \omega = 2\pi \nu$$

than the Kerr cell introduces a time varying phase difference

$$\begin{aligned}
 \delta &= 2\pi B | E_m^2 \sin^2 \omega t \\
 &= 2\pi \times 2.2 \times 10^{-10} \times 10 \times (50 \times 10^3)^2 \sin^2 \omega t \\
 &= 11\pi \sin^2 \omega t
 \end{aligned}$$

In one half-cycle $\left(\text{i.e. in time } \frac{\pi}{\omega} = T/2 = \frac{1}{2\nu} \right)$

this reaches the value $2k\pi$ when

$$\sin^2 \omega t = 0, \frac{2}{11}, \frac{4}{11}, \frac{6}{11}, \frac{8}{11}, \frac{10}{11}$$

$$\frac{2}{11}, \frac{4}{11}, \frac{6}{11}, \frac{8}{11}, \frac{10}{11}$$

i.e. 11 times. On each of these occasions light will be interrupted. Thus light will be interrupted

$$2\nu \times 11 = 2.2 \times 10^8 \text{ times per second}$$

(Light will be interrupted when the Kerr cell (placed between crossed Nicols) introduces a phase difference of $2k\pi$ and in no other case.)

5.195 From problem 189, we know that

$$\Delta n = \frac{\alpha \lambda}{\pi}$$

where α is the rotation constant. Thus

$$\Delta n = \frac{2\alpha}{2\pi/\lambda} = \frac{2\alpha c}{\omega}$$

On the other hand

$$\alpha_{\text{mag}} = VH$$

Thus for the magnetic rotations $\Delta n = \frac{2cVH}{\omega}$.

5.196 Part of the rotations is due to Faraday effect and part of it is ordinary optical rotation. The latter does not change sign when magnetic field is reversed. Thus

$$\varphi_1 = \alpha l + V l H$$

$$\varphi_2 = \alpha l - V l H$$

Hence

$$2V l H = (\varphi_1 - \varphi_2)$$

or

$$V = \left(\frac{\varphi_1 - \varphi_2}{2} \right) / l H$$

Putting the values

$$V = \frac{510 \text{ ang min}}{2 \times .3 \times 56.5} \times 10^{-3} \text{ per A} = 0.015 \text{ ang min/A}$$

5.197 We write

$$\varphi = \varphi_{\text{chemical}} + \varphi_{\text{magnetic}}$$

We look against the transmitted beam and count the positive direction clockwise. The chemical part of the rotation is annulled by reversal of wave vector upon reflection.

Thus

$$\varphi_{\text{chemical}} = \alpha l$$

Since in effect there is a single transmission.

On the other hand

$$\varphi_{\text{mag}} = -NHVl$$

To get the signs right recall that dextro rotatory compounds rotate the plane of vibration in a clockwise direction on looking against the oncoming beam. The sense of rotation of light vibration in Faraday effect is defined in terms of the direction of the field, positive rotation being that of a right handed screw advancing in the direction of the field. This is the opposite of the definition of $\varphi_{\text{chemical}}$ for the present case. Finally

$$\varphi = (\alpha - VNH)l$$

(Note : If plane polarized light is reflected back & forth through the same active medium in a magnetic field, the Faraday rotation increases with each traversal.)

- 5.198 There must be a Faraday rotation by 45° in the opposite direction so that light could pass through the second polaroid. Thus

$$VlH_{\text{min}} = \pi/4$$

or

$$H_{\text{min}} = \frac{\pi/4}{Vl} = \frac{45 \times 60}{2.59 \times 0.26} \frac{\text{A}}{\text{m}}$$

$$= 4.01 \frac{\text{kA}}{\text{m}}$$

If the direction of magnetic field is changed then the sense of rotation will also change. Light will be completely quenched in the above case.

- 5.199 Let r = radius of the disc

then its moment of inertia about its axis = $\frac{1}{2} m r^2$

In time t the disc will acquire an angular momentum

$$t \cdot \pi r^2 \cdot \frac{I}{\omega}$$

when circularly polarized light of intensity I falls on it. By conservation of angular momentum this must equal

$$\frac{1}{2} m r^2 \cdot \omega_0$$

where ω_0 = final angular velocity.

Equating

$$t = \frac{m \omega \omega_0}{2 \pi I}$$

But

$$\frac{\omega}{2 \pi} = v = \frac{c}{\lambda} \quad \text{so } t = \frac{m c \omega_0}{I \lambda}$$

Substituting the values of the various quantities we get

$$t = 11.9 \text{ hours}$$

5.5 DISPERSION AND ABSORPTION OF LIGHT

5.200 In a travelling plane electromagnetic wave the intensity is simply the time averaged magnitude of the Poynting vector :-

$$I = \langle |\vec{E} \times \vec{H}| \rangle = \langle \sqrt{\frac{\epsilon_0}{\mu_0}} E^2 \rangle = \langle c \epsilon_0 E^2 \rangle$$

on using
$$c = \frac{1}{\sqrt{\epsilon_0 \mu_0}}, \quad E \sqrt{\epsilon_0} = H \sqrt{\mu_0}.$$

(see chapter 4.4 of the book).

Now time averaged value of E^2 is $E_0^2/2$ so

$$I = \frac{1}{2} c \epsilon_0 E_0^2 \quad \text{or} \quad E_0 = \sqrt{\frac{2I}{c \epsilon_0}},$$

(a) Represent the electric field at any point by $E = E_0 \sin \omega t$. Then for the electron we have the equation.

$$m \ddot{x} = e E_0 \sin \omega t$$

so
$$x = -\frac{e E_0}{m \omega^2} \sin \omega t$$

The amplitude of the forced oscillation is

$$\frac{e E_0}{m \omega^2} = \frac{e}{m \omega^2} \sqrt{\frac{2I}{c \epsilon_0}} = 5.1 \times 10^{-16} \text{ cm}$$

The velocity amplitude is clearly

$$\frac{e E_0}{m \omega} = 5.1 \times 10^{-16} \times 3.4 \times 10^{15} = 1.73 \text{ cm/sec}$$

(b) For the electric force

$$\begin{aligned} F_e &= \text{amplitude of the electric force} \\ &= e E_0 \end{aligned}$$

For the magnetic force (which we have neglected above), it is

$$\begin{aligned} (e v B) &= (e v \mu_0 H) \\ &= e v E \sqrt{\epsilon_0 \mu_0} = e v \frac{E}{c} \end{aligned}$$

writing $v = -v_0 \cos \omega t$

where
$$v_0 = \frac{e E_0}{m \omega}$$

we see that the magnetic force is apart from a sign

$$\frac{e v_0 E_0}{2 c} \sin 2 \omega t$$

Hence $\frac{F_m}{F_e} = \text{Ratio of amplitudes of the two forces}$

$$= \frac{v_0}{2c} = 2.9 \times 10^{-11}$$

This is negligible and justifies the neglect of magnetic field of the electromagnetic wave in calculating v_0 .

5.201 (a) It turns out that one can neglect the spatial dependence of the electric field as well as the magnetic field. Thus for a typical electron

$$m \vec{r} = e \vec{E}_0 \sin \omega t$$

so $\vec{r} = -\frac{e \vec{E}_0}{m \omega^2} \sin \omega t$ (neglecting any nonsinusoidal part).

The ions will be practically unaffected. Then

$$\vec{P} = n_0 e \vec{r} = -\frac{n_0 e^2}{m \omega^2} \vec{E}$$

and
$$\vec{D} = \epsilon_0 \vec{E} + \vec{P} = \epsilon_0 \left(1 - \frac{n_0 e^2}{\epsilon_0 m \omega^2} \right) \vec{E}$$

Hence the permittivity
$$\epsilon = 1 - \frac{n_0 e^2}{\epsilon_0 m \omega^2}.$$

(b) The phase velocity is given by

$$v = \omega/K = \frac{c}{\sqrt{\epsilon}}$$

So
$$c k = \omega \sqrt{1 - \frac{\omega_p^2}{\omega^2}}, \quad \omega_p^2 = \frac{n_0 e^2}{\epsilon_0 m}$$

$$\omega^2 = c^2 k^2 + \omega_p^2$$

Thus
$$v = c \sqrt{1 + \frac{\omega_p^2}{c^2 k^2}} = c \sqrt{1 + \left(\frac{n_0 e^2}{4 \pi^2 m c^2 \epsilon_0} \right) \lambda^2}$$

5.202 From the previous problem

$$n^2 = 1 - \frac{n_0 e^2}{\epsilon_0 m \omega^2}$$

$$= 1 - \frac{n_0 e^2}{4 \pi^2 \epsilon_0 m v^2}$$

Thus $n_0 = (4 \pi^2 v^2 m \epsilon_0 / e^2) (1 - n^2) = 2.36 \times 10^7 \text{ cm}^{-3}$

5.203 For hard x - rays, the electrons in graphite will behave as if nearly free and the formula of previous problem can be applied. Thus

$$n^2 = 1 - \frac{n_0 e^2}{\epsilon_0 m \omega^2}$$

and

$$n = 1 - \frac{n_0 e^2}{2 \epsilon_0 m \omega^2}$$

on taking square root and neglecting higher order terms.

$$\text{So } n - 1 = - \frac{n_0 e^2}{2 \epsilon_0 m \omega^2} = - \frac{n_0 e^2 \lambda^2}{8 \pi^2 \epsilon_0 m e^2}$$

We calculate n_0 as follows : There are $6 \times 6.023 \times 10^{23}$ electrons in 12 gms of graphite of density 1.6 gm/c.c. Thus

$$n_0 = \frac{6 \times 6.023 \times 10^{23}}{(12/1.6)} \text{ per c.c.}$$

Using the values of other constants and $\lambda = 50 \times 10^{-12}$ metre we get

$$n - 1 = -5.4 \times 10^{-7}$$

5.204 (a) The equation of the electron can (under the stated conditions) be written as

$$m \ddot{x} + \gamma \dot{x} + kx = e E_0 \cos \omega t$$

To solve this equation we shall find it convenient to use complex displacements. Consider the equation

$$m \ddot{z} + \gamma \dot{z} + kz = e E_0 e^{-i\omega t}$$

Its solution is

$$z = \frac{e E_0 e^{-i\omega t}}{-m\omega^2 - i\gamma\omega + k}$$

(we ignore transients.)

Writing

$$\beta = \frac{\gamma}{2m}, \quad \omega_0^2 = \frac{k}{m}$$

we find

$$z = \frac{e E_0}{m} e^{-i\omega t} / (\omega_0^2 - \omega^2 - 2i\beta\omega)$$

Now $x = \text{Real part of } z$

$$= \frac{e E_0}{m} \cdot \frac{\cos(\omega t + \varphi)}{\sqrt{(\omega_0^2 - \omega^2)^2 + 4\beta^2\omega^2}} = a \cos(\omega t + \varphi)$$

where

$$\tan \varphi = \frac{2\beta\omega}{\omega^2 - \omega_0^2}$$

$$\left(\sin \varphi = - \frac{2\beta\omega}{\sqrt{(\omega^2 - \omega_0^2)^2 + 4\beta^2\omega^2}} \right)$$

(b) We calculate the power absorbed as

$$P = \langle F \dot{x} \rangle = \langle e E_0 \cos \omega t (-\omega a \sin(\omega t + \phi)) \rangle$$

$$= e E_0 \cdot \frac{e E_0}{m} \frac{1}{2} \cdot \frac{2 \beta \omega}{(\omega_0^2 - \omega^2)^2 + 4 \beta^2 \omega^2} \cdot \omega = \left(\frac{e E_0}{m} \right)^2 \frac{\beta m \omega^2}{(\omega_0^2 - \omega^2)^2 + 4 \beta^2 \omega^2}$$

This is clearly maximum when $\omega_0 = \omega$ because P can be written as

$$P = \left(\frac{e E_0}{m} \right)^2 \frac{\beta m}{\left(\frac{\omega_0^2}{\omega} - \omega \right)^2 + 4 \beta^2}$$

and

$$P_{\max} = \frac{m}{4 \beta} \left(\frac{e E_0}{m} \right)^2 \quad \text{for } \omega = \omega_0.$$

P can also be calculated from $P = \langle \gamma \dot{x} \cdot \dot{x} \rangle$

$$= (\gamma \omega^2 a^2 / 2) = \frac{\beta m \omega^2 (e E_0 / m)^2}{(\omega_0^2 - \omega^2)^2 + 4 \beta^2 \omega^2}.$$

5.205 Let us write the solutions of the wave equation in the form

$$A = A_0 e^{i(\omega t - kx)}$$

where $k = \frac{2\pi}{\lambda}$ and λ is the wavelength in the medium. If $n' = n + i\chi$, then

$$k = \frac{2\pi}{\lambda_0} n'$$

(λ_0 is the wavelength in vacuum) and the equation becomes

$$A = A_0 e^{\chi' x} \exp(i(\omega t_1 - k' x))$$

where $\chi' = \frac{2\pi}{\lambda_0} \chi$ and $k' = \frac{2\pi}{\lambda_0} n$. In real form,

$$A = A_0 e^{\chi' x} \cos(\omega t - k' x)$$

This represents a plane wave whose amplitude diminishes as it propagates to the right (provided $\chi' < 0$).

when $n' = i\chi$, then similarly

$$A = A_0 e^{\chi' x} \cos \omega t$$

(on putting $n = 0$ in the above equation).

This represents a standing wave whose amplitude diminishes as one goes to the right (if $\chi' < 0$). The wavelength of the wave is infinite ($k' = 0$).

Waves of the former type are realized inside metals as well as inside dielectrics when there is total reflection. (penetration of wave).

5.206 In the plasma radio waves with wavelengths exceeding λ_0 are not propagated. We interpret this to mean that the permittivity becomes negative for such waves. Thus

$$0 = 1 - \frac{n_0 e^2}{\epsilon_0 m \omega^2} \quad \text{if } \omega = \frac{2\pi c}{\lambda_0}$$

Hence

$$\frac{n_0 e^2 \lambda_0^2}{4\pi^2 \epsilon_0 m c^2} = 1$$

or

$$n_0 = \frac{4\pi^2 \epsilon_0 m c^2}{e^2 \lambda_0^2} = 1.984 \times 10^9 \text{ per c.c.}$$

5.207 By definition

$$u = \frac{d\omega}{dk} = \frac{d}{dk}(vk) \quad \text{as } \omega = vk = v + k \frac{dv}{dk}$$

Now $k = \frac{2\pi}{\lambda}$ so $dk = -\frac{2\pi}{\lambda^2} d\lambda$

Thus $u = v - \lambda \frac{dv}{d\lambda}$.

Its interpretation is the following :

$\left(\frac{dv}{d\lambda}\right)_{\lambda=\lambda'}$ is the slope of the $v - \lambda$ curve at $\lambda = \lambda'$. V'

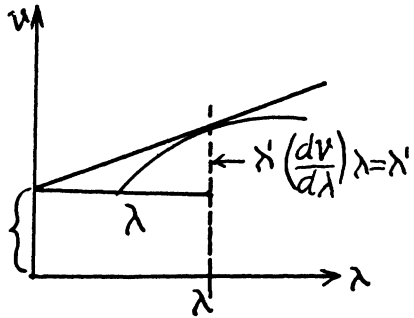

Thus as is obvious from the diagram

$v' = v(\lambda') - \lambda' \left(\frac{dv}{d\lambda}\right)_{\lambda=\lambda'}$ is the group velocity for $\lambda = \lambda'$.

5.208 (a) $v = a/\sqrt{\lambda}$, $a = \text{constant}$

Then

$$u = v - \lambda \frac{dv}{d\lambda}$$

$$= \frac{a}{\sqrt{\lambda}} - \lambda \left(-\frac{1}{2} a \lambda^{-3/2}\right) = \frac{3}{2} \cdot \frac{a}{\sqrt{\lambda}} = \frac{3}{2} v.$$

(b) $v = bk = \omega k$, $b = \text{constant}$

so $\omega = bk^2$ and $u = \frac{d\omega}{dk} = 2bk = 2v.$

(c) $v = \frac{c}{\omega^2}$, $c = \text{constant} = \frac{\omega}{k}$.

so $\omega^3 = ck$ or $\omega = c^{1/3} k^{1/3}$

Thus $u = \frac{d\omega}{dk} = c^{1/3} \frac{1}{3} k^{-2/3} = \frac{1}{3} \frac{\omega}{k} = \frac{1}{3} v$

5.209 We have

$$u v = \frac{\omega}{k} \frac{d\omega}{dk} = c^2$$

Integrating we find

$$\omega^2 = A + c^2 k^2, \quad A \text{ is a constant.}$$

so

$$k = \frac{\sqrt{\omega^2 - A}}{c}$$

and

$$v = \frac{\omega}{k} = \frac{c}{\sqrt{1 - \frac{A}{\omega^2}}}$$

writing this as $c/\sqrt{\epsilon(\omega)}$ we get $\epsilon(\omega) = 1 - \frac{A}{\omega^2}$

(A can be +ve or negative)

5.210 The phase velocity of light in the vicinity of $\lambda = 534 \text{ nm} = \lambda_0$ is obtained as

$$v(\lambda_0) = \frac{c}{n(\lambda_0)} = \frac{3 \times 10^8}{1.640} = 1.829 \times 10^8 \text{ m/s}$$

To get the group velocity we need to calculate

$$\left(\frac{dn}{d\lambda} \right)_{\lambda = \lambda_0} \cdot \text{We shall use linear}$$

interpolation in the two intervals. Thus

$$\left(\frac{dn}{d\lambda} \right)_{\lambda = 521.5} = -\frac{.007}{25} = -28 \times 10^{-5} \text{ per nm}$$

$$\left(\frac{dn}{d\lambda} \right)_{\lambda = 561.5} = -\frac{.01}{55} = -18.2 \times 10^{-5} \text{ per nm}$$

There $(dn/d\lambda)$ values have been assigned to the mid-points of the two intervals.

Interpolating again we get

$$\left(\frac{dn}{d\lambda} \right)_{\lambda = 534} = \left[-28 + \frac{9.8}{40} \times 12.5 \right] \times 10^{-5} \text{ per nm} = -24.9 \times 10^{-5} \text{ per nm.}$$

Finally

$$u = \frac{c}{n} - \lambda \frac{d}{d\lambda} \left(\frac{c}{n} \right) = \frac{c}{n} \left[1 + \frac{\lambda}{n} \left(\frac{dn}{d\lambda} \right) \right]$$

At $\lambda = 534$

$$u = \frac{3 \times 10^8}{1.640} \left[1 - \frac{534}{1.640} \times 24.9 \times 10^{-5} \right] \text{ m/s} = 1.59 \times 10^8 \text{ m/s}$$

5.211 We write

$$v = \frac{\omega}{k} = a + b\lambda$$

so

$$\omega = k(a + b\lambda) = 2\pi b + ak.$$

(since $k = \frac{2\pi}{\lambda}$). Suppose a wavetrain at time $t = 0$ has the form

$$F(x, 0) = \int f(k) e^{ikx} dk$$

Then at time t it will have the form

$$\begin{aligned} F(x, t) &= \int f(k) e^{ikx - i\omega t} dk \\ &= \int f(k) e^{ikx - i(2\pi b + ak)t} = \int f(k) e^{ik(x - at)} e^{-i2\pi bt} dk \end{aligned}$$

At $t = \frac{1}{b} = \tau$

$$F(x, \tau) = F(x - a\tau, 0)$$

so at time $t = \tau$ the wave train has regained its shape though it has advanced by $a\tau$.

5.212

On passing through the first (polarizer) Nicol the intensity of light becomes $\frac{1}{2}I_0$ because one of the components has been cut off. On passing through the solution the plane of polarization of the light beam will rotate by

$$\varphi = V/H$$

and its intensity will also decrease by a factor $e^{-x'}$. The plane of vibration of the light wave will then make an angle $90^\circ - \varphi$ with the principal direction of the analyzer Nicol. Thus by Malus' law the intensity of light coming out of the second Nicol will be

$$\begin{aligned} \frac{1}{2}I_0 \cdot e^{-x'} \cdot \cos^2(90^\circ - \varphi) \\ = \frac{1}{2}I_0 e^{-x'} \sin^2 \varphi. \end{aligned}$$

5.213 (a) The multiple reflections are shown below. Transmission gives a factor $(1 - \rho)$ while reflections give factors of ρ . Thus the transmitted intensity assuming incoherent light is

$$\begin{aligned} (1 - \rho)^2 I_0 + (1 - \rho)^2 \rho^2 I_0 + (1 - \rho)^2 \rho^4 I_0 + \dots \\ = (1 - \rho)^2 I_0 (1 + \rho^2 + \rho^4 + \rho^6 + \dots) \\ = (1 - \rho)^2 I_0 \times \frac{1}{1 - \rho^2} = I_0 \frac{1 - \rho}{1 + \rho}. \end{aligned}$$

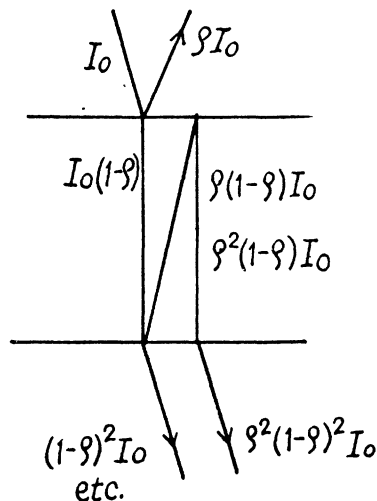

- (b) When there is absorption, we pick up a factor $\sigma = e^{-\chi d}$ in each traversal of the plate. Thus we get

$$\begin{aligned} & (1 - \rho)^2 \sigma I_0 + (1 - \rho)^2 \sigma^3 \rho^2 I_0 + (1 - \rho)^2 \sigma^5 \rho^4 I_0 + \dots \\ &= (1 - \rho)^2 \sigma I_0 (1 + \sigma^2 \rho^2 + \sigma^4 \rho^4 + \dots) \\ &= I_0 \frac{\sigma (1 - \rho)^2}{1 - \sigma^2 \rho^2} \end{aligned}$$

5.214 We have

$$\begin{aligned} \tau_1 &= e^{-\chi d_1} (1 - \rho)^2 \\ \tau_2 &= e^{-\chi d_2} (1 - \rho)^2 \end{aligned}$$

where ρ is the reflectivity; see previous problem, multiple reflection have been ignored.

Thus

$$\frac{\tau_1}{\tau_2} = e^{\chi(d_2 - d_1)}$$

or

$$\chi = \frac{\ln\left(\frac{\tau_1}{\tau_2}\right)}{d_2 - d_1} = 0.35 \text{ cm}^{-1}.$$

5.215 On each surface we pick up a factor $(1 - \rho)$ from reflection and a factor $e^{-\chi l}$ due to absorption in each plate.

Thus

$$\tau = (1 - \rho)^{2N} e^{-\chi N l}$$

Thus

$$\chi = \frac{1}{N l} \ln \frac{(1 - \rho)^{2N}}{\tau} = 0.034 \text{ cm}^{-1}.$$

5.216 Apart from the factor $(1 - \rho)$ on each end face of the plate, we shall get a factor due to absorptions. This factor can be calculated by assuming the plate to consist of a large number of very thin slab within each of which the absorption coefficient can be assumed to be constant. Thus we shall get a product like

$$\dots e^{-\chi(x)dx} e^{-\chi(x+dx)dx} e^{-\chi(x+2dx)dx} \dots$$

This product is nothing but

$$e^{-\int_0^l \chi(x) dx}$$

Now $\chi(0) = \chi_1$, $\chi(l) = \chi_2$ and variation

with x is linear so $\chi(x) = \chi_1 + \frac{x}{l}(\chi_2 - \chi_1)$

Thus the factor becomes

$$e^{-\int_0^l \left[\chi_1 + \frac{x}{l}(\chi_2 - \chi_1) \right] dx} = e^{-\frac{1}{2}(\chi_1 + \chi_2)l}$$

5.217 The spectral density of the incident beam (i.e. intensity of the components whose wave length lies in the interval λ & $\lambda + d\lambda$) is

$$\frac{I_0}{\lambda_2 - \lambda_1} d\lambda, \lambda_1 \leq \lambda \leq \lambda_2$$

The absorption factor for this component is

$$e^{-\left[x_1 + \frac{\lambda + \lambda_1}{\lambda_2 - \lambda_1} (x_2 - x_1)\right]l}$$

and the transmission factor due to reflection at the surface is $(1 - \rho)^2$. Thus the intensity of the transmitted beam is

$$\begin{aligned} & (1 - \rho)^2 \frac{I_0}{\lambda_2 - \lambda_1} \int_{\lambda_1}^{\lambda_2} d\lambda e^{-l\left[x_1 + \frac{\lambda - \lambda_1}{\lambda_2 - \lambda_1} (x_2 - x_1)\right]} \\ &= (1 - \rho)^2 \frac{I_0}{\lambda_2 - \lambda_1} e^{-x_1 l} \left(\frac{1 - e^{-(x_2 - x_1)l}}{(x_2 - x_1)l} \right) \chi(\lambda_2 - \lambda_1) = (1 - \rho)^2 I_0 \frac{e^{-x_1 l} - e^{-x_2 l}}{(x_2 - x_1)l} \end{aligned}$$

5.218 At the wavelength λ_0 , the absorption coefficient vanishes and loss in transmission is entirely due to reflection. This factor is the same at all wavelengths and therefore cancels out in calculating the pass band and we need not worry about it. Now

$$T_0 = (\text{transmissivity at } \lambda = \lambda_0) = (1 - \rho)^2$$

$$T = \text{transmissivity at } \lambda = (1 - \rho)^2 e^{-\chi(\lambda)d}$$

The edges of the passband are $\lambda_0 \pm \frac{\Delta\lambda}{2}$ and at the edge

$$\frac{T}{T_0} = e^{-\alpha d \left(\frac{\Delta\lambda}{2\lambda_0}\right)^2} = \eta$$

Thus
$$\frac{\Delta\lambda}{2\lambda_0} = \sqrt{\left(\ln \frac{1}{\eta}\right) / \alpha d}$$

or
$$\Delta\lambda = 2\lambda_0 \sqrt{\frac{1}{\alpha d} \left(\ln \frac{1}{\eta}\right)}$$

5.219 We have to derive the law of decrease of intensity in an absorbing medium taking in to account the natural geometrical fall-off (inverse square law) as well as absorption. Consider a thin spherical shell of thickness dx and internal radius x . Let $I(x)$ and $I(x + dx)$ be the intensities at the inner and outer surfaces of this shell.

Then
$$4\pi x^2 I(x) e^{-x dx} = 4\pi (x + dx)^2 I(x + dx)$$

Except for the factor $e^{-x dx}$ this is the usual equation. We rewrite this as

$$x^2 I(x) = I(x + dx) (x + dx)^2 (1 + \chi dx)$$

$$= \left(I + \frac{dI}{dx} dx \right) (x^2 + 2x dx) (1 + \chi dx)$$

or
$$x^2 \frac{dI}{dx} + \chi x^2 I + 2xI = 0$$

Hence
$$\frac{d}{dx} (x^2 I) + \chi (x^2 I) = 0$$

so
$$x^2 I = C e^{-\chi x}$$

where C is a constant of integration.

In our case we apply this equation for $a \leq x \leq b$

For $x \leq a$ the usual inverse square law gives

$$I(a) = \frac{\Phi}{4\pi a^2}$$

Hence
$$C = \frac{\Phi}{4\pi} e^{\chi a}$$

and
$$I(b) = \frac{\Phi}{4\pi b^2} e^{-\chi(b-a)}$$

This does not take into account reflections. When we do that we get

$$I(b) = \frac{\Phi}{4\pi b^2} (1 - \rho)^2 e^{-\chi(b-a)}$$

5.220 The transmission factor is $e^{-\mu d}$ and so the intensity will decrease $e^{\mu d}$

$$= e^{3.6 \times 11.3 \times 0.1} = 58.4 \text{ timestimes}$$

(we have used $\mu = (\mu/\rho) \times \rho$ and used the known value of density of lead).

5.221 We require $\mu_{pb} d_{pb} = \mu_{Al} d_{Al}$

or
$$\left(\frac{\mu_{pb}}{\rho_{pb}} \right) \rho_{pb} d_{pb} = \left(\frac{\mu_{Al}}{\rho_{Al}} \right) \rho_{Al} d_{Al}$$

$$72.0 \times 11.3 \times d_{pb} = 3.48 \times 2.7 \times 2.6$$

$$d_{pb} = 0.3 \text{ m m}$$

5.222 $\frac{1}{2} = e^{-\mu d}$

or
$$d = \frac{\ln 2}{\mu} = \frac{\ln 2}{\left(\frac{\mu}{\rho} \right) \rho} = 0.80 \text{ cm}$$

5.223 We require N plates where

$$\left(\frac{1}{2} \right)^N = \frac{1}{50} \quad \text{So } N = \frac{\ln 50}{\ln 2} = 5.6$$

5.6 OPTICS OF MOVING SOURCES

5.224 In the Fizeau experiment, light disappears when the wheel rotates to bring a tooth in the position formerly occupied by a gap in the time taken by light to go from the wheel to the mirror and back. Thus distance travelled = $2l$. Suppose the m^{th} tooth after the gap has come in place of the latter. Then time taken

$$= \frac{2(m-1) + 1}{2z n_1} \text{ sec. in the first case}$$

$$= \frac{2m+1}{2z n_2} \text{ sec in the second case} = \frac{1}{z(n_2 - n_1)}$$

Then $c = 2lz(n_2 - n_1) = 3.024 \times 10^8 \text{ m/sec}$

5.225 When $v \ll c$ time dilation effect of relativity can be neglected (i.e. $t' \approx t$) and we can use time in the reference frame fixed to the observer. Suppose the source emits short pulses with intervals T_0 . Then in the reference frame fixed to the receiver the distance between two successive pulses is $\lambda = cT_0 - v_r T_0$ when measured along the observation line.

Here $v_r = v \cos \theta$ is the projection of the source velocity on the observation line. The frequency of the pulses received by the observer is

$$v = \frac{c}{\lambda} = \frac{v_0}{1 - \frac{v_r}{c}} \approx v_0 \left(1 + \frac{v_r}{c} \right)$$

(The formula is accurate to first order only)

$$\text{Thus } \frac{v - v_0}{v_0} = \frac{v_r}{c} = \frac{v \cos \theta}{c}$$

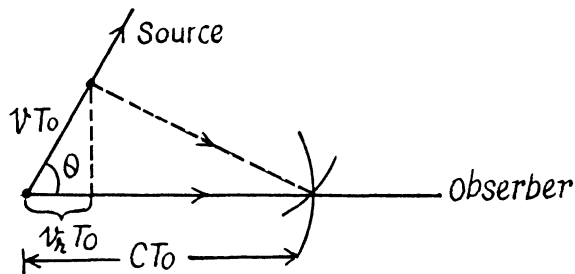

The frequency increases when the source is moving towards the observer.

5.226 $\frac{\Delta v}{v} = \frac{v}{c} \cos \theta$ from the previous problem

But $v\lambda = c$ gives an differentiation

$$\frac{\Delta v}{v} = - \frac{\Delta \lambda}{\lambda}$$

$$\text{So } \Delta \lambda = -\lambda \sqrt{\frac{v^2}{c^2}} \cos \theta = -\lambda \sqrt{\frac{2T}{m c^2}} \cos \theta$$

on using $T = \frac{1}{2} m v^2$, $m = \text{mass of He}^+$ ion

We use $m c^2 = 4 \times 938 \text{ MeV}$. Putting other values

$$\Delta \lambda = -26 \text{ nm}$$

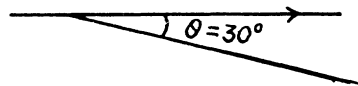

5.227 One end of the solar disc is moving towards us while the other end is moving away from us. The angle θ between the direction in which the edges of the disc are moving and the line of observation is small ($\cos \theta \approx 1$). Thus

$$\frac{\Delta \lambda}{\lambda} = \frac{2 \omega R}{c}$$

where $\omega = \frac{2\pi}{T}$ is the angular velocity of the Sun. Thus

$$\omega = \frac{c \Delta \lambda}{2 R \lambda}$$

So

$$T = \frac{4 \pi R \lambda}{c \Delta \lambda}$$

Putting the values ($R = 6.95 \times 10^8$ m)

we get

$$T = 24.85 \text{ days}$$

5.228 Maximum splitting of the spectral lines

will occur when both of the stars are moving in the direction of line of observation as shown. We then have the equations

$$\begin{aligned} \left(\frac{\Delta \lambda}{\lambda} \right)_m &= \frac{2v}{c} \\ \frac{mv^2}{R} &= \frac{\gamma m^2}{4R^2} \\ \tau &= \frac{\pi R}{v} \end{aligned}$$

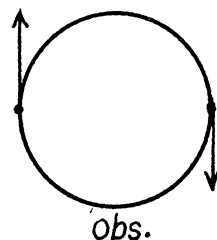

From these we get

$$d = 2R = \left(\frac{\Delta \lambda}{\lambda} \right)_m c \tau / \pi = 2.97 \times 10^7 \text{ km}$$

$$m = \left(\frac{\Delta \lambda}{\lambda} \right)_m^3 c^3 \tau / 2 \pi \gamma = 2.9 \times 10^{29} \text{ kg}$$

5.229 We define the frame S (the lab frame) by the condition of the problem. In this frame the mirror is moving with velocity v (along say x - axis) towards left and light of frequency ω_0 is approaching it from the left. We introduce the frame S' whose axes are parallel to those of S but which is moving with velocity v along x axis towards left (so that the mirror is at rest in S'). In S' the frequency of the incident light is

$$\omega_1 = \omega_0 \left(\frac{1 + v/c}{1 - v/c} \right)^{1/2}$$

In S' the reflected light still has frequency ω_1 but it is now moving towards left. When we transform back to S this reflected light has the frequency

$$\omega = \omega_1 \left(\frac{1+v/c}{1-v/c} \right)^{1/2} = \omega_0 \left(\frac{1+v/c}{1-v/c} \right)$$

In the nonrelativistic limit

$$\omega \approx \omega_0 \left(1 + \frac{2v}{c} \right)$$

5.230 From the previous problem, the beat frequency is clearly

$$\Delta v = v_0 \frac{2v}{c} = 2v / (c/v_0) = 2v / \lambda_0$$

Hence
$$v = \frac{1}{2} \lambda \Delta v = \frac{10^3}{2} \times 50 \text{ cm/sec} = 900 \text{ km/hour}$$

5.231 From the invariance of phase under Lorentz transformations we get

$$\omega t - kx = \omega' t' - k' x'$$

Here $\omega = ck$. The primed coordinates refer to the frame S' which is moving to the right with velocity v :-

Then $x' = \gamma(x - vt)$

$$t' = \gamma \left(t - \frac{vx}{c^2} \right)$$

where
$$\gamma = \left(\sqrt{1 - v^2/c^2} \right)^{-1}$$

Substituting and equating the coefficients of t & x

$$\omega = \gamma \omega' + \gamma k' v = \omega' \frac{1+v/c}{\sqrt{1-v^2/c^2}}$$

$$k = \gamma \frac{\omega' v}{c^2} + \gamma k' = k' \frac{1+v/c}{\sqrt{1-v^2/c^2}}$$

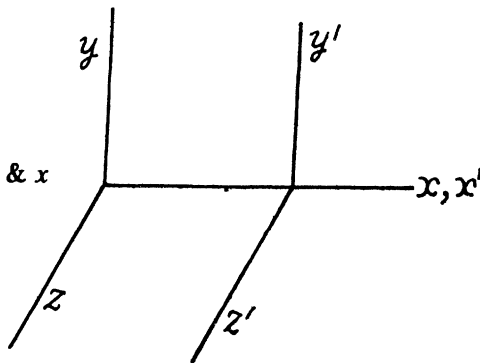

5.232 From the previous problem using

$$k = \frac{2\pi}{\lambda}$$

we get

$$\lambda' = \lambda \sqrt{\frac{1+v/c}{1-v/c}}$$

Thus

$$\frac{1 + \frac{v}{c}}{1 - v/c} = \frac{\lambda'^2}{\lambda^2}$$

or

$$v/c = \frac{\lambda'^2 - \lambda^2}{\lambda'^2 + \lambda^2} = \frac{564^2 - 434^2}{564^2 + 434^2} = 0.256$$

5.233 As in the previous problem

$$\frac{v}{c} = \frac{\lambda^2 - \lambda'^2}{\lambda^2 + \lambda'^2}$$

so

$$v = c \frac{\left(\frac{\lambda}{\lambda'}\right)^2 - 1}{\left(\frac{\lambda}{\lambda'}\right)^2 + 1} = 7.1 \times 10^4 \text{ k m/s}$$

5.233 We go to the frame in which the observer is at rest. In this frame the velocity of the source of light is, by relativistic velocity addition formula,

$$v = \frac{\frac{3}{4}c - \frac{1}{2}c}{1 - \left(\frac{3}{4}c \cdot \frac{1}{2}c/c^2\right)} = \frac{2c}{5}.$$

When this source emits light of proper frequency ω_0 , the frequency recorded by observer will be

$$\omega = \omega_0 \sqrt{\frac{1 - v/c}{1 + v/c} + v/c} = \sqrt{\frac{3}{7}} \omega_0$$

Note that $\omega < \omega_0$ as the source is moving away from the observer (red shift).

5.235 In transverse Doppler effect.

$$\omega = \omega_0 \sqrt{1 - \beta^2} = \omega_0 \left(1 - \frac{1}{2}\beta^2\right)$$

So

$$\lambda = \frac{c}{\omega} = \frac{c}{\omega_0} \left(1 + \frac{1}{2}\beta^2\right) = \lambda_0 \left(1 + \frac{1}{2}\beta^2\right)$$

Hence

$$\Delta \lambda = \frac{1}{2}\beta^2 \lambda$$

Using $\beta^2 = \frac{v^2}{c^2} = \frac{2T}{mc^2}$, where $T = \text{K.E of } H \text{ atoms}$

$$\Delta \lambda = \frac{T}{mc^2} \lambda = \frac{1}{938} \times 656.3 \text{ nm} = 0.70 \text{ nm}$$

5.236 (a) If light is received by the observer at P at the moment when the source is at O , it must have been emitted by the source when it was at O' and travelled along $O'P$. Then if $O'P = ct$, $O'O = vt$

and $\cos \theta = \frac{v}{c} = \beta$

In the frame of the observer, the frequency of the light is ω while its wave vector is

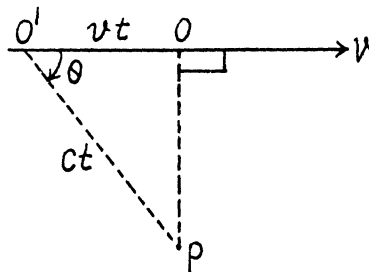

$$\frac{\omega}{c} (\cos \theta, \sin \theta, 0)$$

we can calculate the value of ω by relating it to proper frequency ω_0 . The relation is

$$\omega_0 = \frac{\omega}{\sqrt{1 - \beta^2}} (1 - \beta \cos \theta)$$

(To derive the formula in this form it is easiest to note that $\frac{\omega}{\sqrt{1 - v/c^2}} - \frac{\vec{k} \cdot \vec{v}}{\sqrt{1 - v^2/c^2}}$ is an invariant which takes the value ω_0 in the rest frame of the source).

Thus

$$\omega = \frac{\omega_0 \sqrt{1 - \beta^2}}{1 - \beta^2} = \frac{\omega_0}{\sqrt{1 - \beta^2}} = 5 \times 10^{10} \text{ sec}^{-1}$$

- (b) For the light to be received at the instant the observer sees the source at O , light must be emitted when the observer is at O at $90^\circ = \theta$

$$\cos \theta = 0$$

Then as before $\omega_0 = \frac{\omega}{\sqrt{1 - \beta^2}}$ or $\omega = \omega_0 \sqrt{1 - \beta^2} = 1.8 \times 10^{10} \text{ sec}^{-1}$

In this case the observer will receive light along OP and he will “see” that the source is at O even though the source will have moved ahead at the instant the light is received.

- 5.237** An electron moving in front of a metal mirror sees an image charge of equal and opposite type. The two together constitute a dipole. Let us look at the problem in the rest frame of the electron. In this frame the grating period is Lorentz contracted to

$$d' = d \sqrt{1 - v^2/c^2}$$

Because the metal has etchings the dipole moment of electron-image pair is periodically disturbed with a period $\frac{d'}{v}$

The corresponding frequency is $\frac{v}{d'}$ which is also the proper frequency of radiation emitted.

Due to Doppler effect the frequency observed at an angle θ is

$$v = v' \frac{\sqrt{1 - (v/c)^2}}{1 - \frac{v}{c} \cos \theta} = \frac{v/d}{1 - \frac{v}{c} \cos \theta}$$

The corresponding wave length is $\lambda = \frac{c}{v} = d \left(\frac{c}{v} - \cos \theta \right)$

Putting

$$c = v, \theta = 45^\circ, d = 2 \mu m \text{ we get}$$

$$\lambda = 0.586 \mu m$$

- 5.238 (a) Let v_x be the projection of the velocity vector of the radiating atom on the observation direction. The number of atoms with projections falling within the interval v_x and $v_x + dv_x$ is

$$n(v_x) dv_x \sim \exp(-m v_x^2 / 2kT) dv_x$$

The frequency of light emitted by the atoms moving with velocity v_x is

$\omega = \omega_0 \left(1 + \frac{v_x}{c}\right)$. From the expressions the frequency distribution of atoms can be found : $n(\omega) d\omega = n(v_x) dv_x$. Now using

$$v_x = c \frac{\omega - \omega_0}{\omega_0}$$

we get $n(\omega) d\omega \sim \exp\left(-\frac{m c^2}{2kT} \left(1 - \frac{\omega}{\omega_0}\right)^2\right) \frac{c d\omega}{\omega_0}$

Now the spectral radiation density $I_\omega \propto n_\omega$

Hence $I_\omega = I_0 e^{-a \left(1 - \frac{\omega}{\omega_0}\right)^2}$, $a = \frac{m c^2}{2kT}$.

(The constant of proportionality is fixed by I_0 .)

- (b) On putting $\omega = \omega_0 \pm \frac{1}{2} \Delta \omega$ and demanding

$$I_\omega = I_0/2$$

we get $\frac{1}{2} = e^{-a \left(\frac{\Delta \omega}{2\omega_0}\right)^2}$

so $a \left(\frac{\Delta \omega}{2\omega_0}\right)^2 = \ln 2$

Hence $\frac{\Delta \omega}{2\omega_0} = \sqrt{(2 \ln 2) kT/m c^2}$

and $\frac{\Delta \omega}{\omega} = 2 \sqrt{(2 \ln 2) kT/m c^2}$

- 5.239 In vacuum inertial frames are all equivalent; the velocity of light is c in any frame. This equivalence of inertial frames does not hold in material media and here the frame in which the medium is at rest is singled out. It is in this frame that the velocity of light is $\frac{c}{n}$ where n is the refractive index of light for that medium. The velocity of light in the frame in which the medium is moving is then by the law of addition of velocities

$$\begin{aligned}\frac{\frac{c}{n} + v}{1 + \frac{c}{n} \cdot v/c^2} &= \frac{\frac{c}{n} + v}{1 + \frac{v}{cn}} = \left(\frac{c}{n} + v\right) \left(1 - \frac{v}{cn} + \dots\right) \\ &= \frac{c}{n} + v - \frac{v}{n^2} + \dots = \frac{c}{n} + v \left(1 - \frac{1}{n^2}\right)\end{aligned}$$

This is the velocity of light in the medium in a frame in which the medium is moving with velocity $v \ll c$.

5.240 Although speed of light is the same in all inertial frames of reference according to the principles of relativity, the direction of a light ray can appear different in different frames.

This phenomenon is called aberration and to first order in $\frac{v}{c}$, can be calculated by the elementary law of addition of velocities applied to light waves.

The angle of aberration is

$$\tan^{-1} \frac{v}{c}.$$

and in the present case it equals $\frac{1}{2} \delta \theta$ on either side. Thus equating

$$\frac{v}{c} = \tan \frac{1}{2} \delta \theta \approx \frac{1}{2} \delta \theta \quad (\delta \theta \text{ radians})$$

or

$$\begin{aligned}v &= \frac{c}{2} \delta \theta = \frac{3 \times 10^8}{2} \times \frac{41}{3600} \times \frac{\pi}{180} \\ &= \frac{3 \times 4.1 \times \pi}{3.6 \times 3.6} \times 10^4 \text{ m/s} = 29.8 \text{ k m/sec}\end{aligned}$$

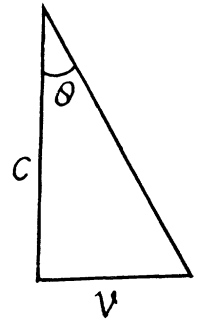

5.241 We consider the invariance of the phase of a wave moving in the $x - y$ plane.

We write

$$\omega' t' - k'_x x' - k'_y y' = \omega t - k_x x - k_y y$$

From Lorentz transformations, L.H.S.

$$= \omega' \gamma \left(t - \frac{v x}{c^2} \right) - k'_x (x - v t) \gamma - k'_y y$$

so equating

$$\omega = \gamma (\omega' + v k'_x)$$

$$k'_x = \gamma \left(k'_x + \frac{v \omega'}{c^2} \right) \quad \text{and} \quad k_y = k'_y$$

so inverting

$$\omega' = \gamma (\omega - v k_x)$$

$$k'_x = \gamma \left(k_x - \frac{v \omega}{c^2} \right)$$

$$k'_y = k_y$$

writing

$$k'_x = k' \cos \theta', \quad k_x = k \cos \theta$$

$$k'_y = k' \sin \theta', \quad k_y = k \sin \theta$$

where $v = \frac{c}{n}$ is the phase velocity of light. It is evident that the radiation is possible only if $V > v$ i.e. when the velocity of the particle exceeds the phase velocity of light in the medium.

5.244 We must have

$$V \geq \frac{c}{n} = \frac{3}{1.6} \times 10^8 \text{ m/s} \quad \text{or} \quad \frac{V}{c} \geq \frac{1}{1.6}$$

For electrons this means a K.E. greater than

$$\begin{aligned} T_e &\geq \frac{m_e c^2}{\sqrt{1 - \left(\frac{1}{1.6}\right)^2}} - m_e c^2 = m_e c^2 \left[\frac{n}{\sqrt{n^2 - 1}} - 1 \right] \\ &= 0.511 \left[\frac{1}{\sqrt{1 - \left(\frac{1}{1.6}\right)^2}} - 1 \right] \quad \text{using } m_e c^2 = 0.511 \text{ MeV} = 0.144 \text{ MeV} \end{aligned}$$

For protons with $m_p c^2 = 938 \text{ MeV}$

$$T_p \geq 938 \left[\frac{1}{\sqrt{1 - \left(\frac{1}{1.6}\right)^2}} - 1 \right] = 264 \text{ MeV} = 0.264 \text{ GeV}$$

Also
$$T_{\text{min}} = 29.6 \text{ MeV} = m c^2 \left[\frac{1}{\sqrt{1 - \left(\frac{1}{1.6}\right)^2}} - 1 \right]$$

Then $m c^2 = 105.3 \text{ MeV}$. This is very nearly the mass of means.

5.245 From $\cos \theta = \frac{v}{V}$

we get

$$V = v \sec \theta$$

so
$$\frac{V}{c} = \frac{v}{c} \sec \theta = \frac{\sec \theta}{n} = \frac{\sec 30^\circ}{1.5} = \frac{2/\sqrt{3}}{3/2} = \frac{4}{3\sqrt{3}}$$

Thus for electrons

$$T_e = 0.511 \left[\frac{1}{\sqrt{1 - \frac{16}{27}}} - 1 \right] = 0.511 \left[\sqrt{\frac{27}{11}} - 1 \right] = 0.289 \text{ MeV}$$

Generally
$$T = m c^2 \left[\frac{1}{\sqrt{1 - \frac{1}{n^2 \cos^2 \theta}}} - 1 \right]$$

5.7 THERMAL RADIATION. QUANTUM NATURE OF LIGHT

5.246 (a) The most probable radiation frequency ω_{pr} is the frequency for which

$$\frac{d}{d\omega} u_{\omega} = 3 \omega^2 F(\omega/T) + \frac{\omega^3}{T} F'(\omega/T) = 0$$

The maximum frequency is the root other than $\omega = 0$ of this equation. It is

$$\omega = -\frac{3TF(\omega/T)}{F'(\omega/T)}$$

or $\omega_{pr} = x_0 T$ where x_0 is the solution of the transcendental equation

$$3F(x_0) + x_0 F'(x_0) = 0$$

(b) The maximum spectral density is the density corresponding to most probable frequency. It is

$$(u_{\omega})_{\max} = x_0^3 F(x_0) T^3 \propto T^3$$

where x_0 is defined above.

(c) The radiosity is

$$M_e = \frac{c}{4} \int_0^{\infty} \omega^3 F\left(\frac{\omega}{T}\right) d\omega = T^4 \left[\frac{c}{4} \int_0^{\infty} x^3 F(x) dx \right] \propto T^4$$

5.247 For the first black body

$$(\lambda_m)_1 = \frac{b}{T_1}$$

Then

$$(\lambda_m)_2 = \frac{b}{T_1} + \Delta\lambda = \frac{b}{T_2}$$

Hence

$$T_2 = \frac{b}{\frac{b}{T_1} + \Delta\lambda} = \frac{b T_1}{b + T_1 \Delta\lambda} = 1.747 k K$$

5.248 From the radiosity we get the temperature of the black body. It is

$$T = \left(\frac{M_e}{\sigma} \right)^{1/4} = \left(\frac{3.0 \times 10^4}{5.67 \times 10^{-8}} \right)^{1/4} = 852.9 K$$

Hence the wavelength corresponding to the maximum emissive capacity of the body is

$$\frac{b}{T} = \frac{0.29}{852.9} \text{ cm} = 3.4 \times 10^{-4} \text{ cm} = 3.4 \mu\text{m}$$

(Note that $3.0 \text{ W/cm}^2 = 3.0 \times 10^4 \text{ W/m}^2$.)

5.249 The black body temperature of the sun may be taken as

$$T_{\odot} = \frac{0.29}{0.48 \times 10^{-4}} = 6042 K$$

Thus the radiosity is

$$M_{e\odot} = 5.67 \times 10^{-8} (6042)^4 = 0.7555 \times 10^8 \text{ W/m}^2$$

Energy lost by sun is

$$4\pi (6.95)^2 \times 10^{16} \times 0.7555 \times 10^8 = 4.5855 \times 10^{26} \text{ watt}$$

This corresponds to a mass loss of

$$\frac{4.5855 \times 10^{26}}{9 \times 10^{16}} \text{ kg/sec} = 5.1 \times 10^9 \text{ kg/sec}$$

The sun loses 1 % of its mass in

$$\frac{1.97 \times 10^{30} \times 10^{-2}}{5.1 \times 10^9} \text{ sec} = 1.22 \times 10^{11} \text{ years.}$$

5.250 For an ideal gas $p = nkT$ where n = number density of the particles and $k = \frac{R}{N_A}$ is Boltzman constant. In a fully ionized hydrogen plasma, both H ions (protons) and electrons contribute to pressure but since the mass of electrons is quite small ($\approx m_p/1836$), only protons contribute to mass density. Thus

$$n = \frac{2\rho}{m_H}$$

and

$$p = \frac{2\rho R}{N_A m_H} T$$

where $m_H \approx m_p$ is the proton or hydrogen mass.

Equating this to thermal radiation pressure

$$\frac{2\rho R}{N_A m_H} T = \frac{u}{3} = \frac{M_e}{3} \times \frac{4}{c} = \frac{4\sigma T^4}{3c}$$

Then

$$T^3 = \frac{3c\rho R}{2\sigma N_A m_H} = \frac{3c\rho R}{\sigma M}$$

where $M = 2N_A m_H$ = molecular weight of hydrogen = 2×10^{-3} kg.

Thus

$$T = \left(\frac{3c\rho R}{\sigma M} \right)^{1/3} \approx 1.89 \times 10^7 \text{ K}$$

5.251 In time dt after the instant t when the temperature of the ball is T , it loses

$$\pi d^2 \sigma T^4 dt$$

Joules of energy. As a result its temperature falls by $-dT$ and

$$\pi d^2 \sigma T^4 dt = -\frac{\pi}{6} d^3 \rho C dT$$

where ρ = density of copper, C = its sp.heat

Thus
$$dt = -\frac{C \rho d}{6 \sigma} \frac{dT}{T^4}$$

or
$$t_0 = \frac{C \rho d}{6 \sigma} \int_{T_0}^{T_0/\eta} -\frac{dT}{T^4} = \frac{C \rho d}{18 \sigma T_0^3} (\eta^3 - 1) = 2.94 \text{ hours.}$$

5.252 Taking account of cosine law of emission we write for the energy radiated per second by the hole in cavity # 1 as

$$dI(\Omega) = A \cos \theta d\Omega$$

where A is an constant, $d\Omega$ is an element of solid angle around some direction defined by the symbol Ω . Integrating over the whole forward hemisphere we get

$$I = A \int_0^{\pi/2} \cos \theta 2\pi \sin \theta d\theta = \pi A$$

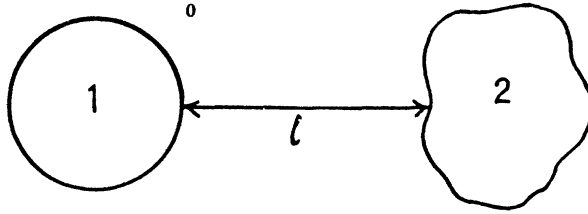

We find A by equating this to the quantity $\sigma T_1^4 \cdot \frac{\pi d^2}{4}$ σ is Stefan-Boltzmann constant and d is the diameter of the hole.

Then
$$A = \frac{1}{4} \sigma d^2 T_1^4$$

Now energy reaching 2 from 1 is ($\cos \theta = 1$)

$$\frac{1}{4} \sigma d^2 T_1^4 \cdot \Delta \Omega$$

where $\Delta \Omega = \frac{(\pi d^2/4)}{l^2}$ is the solid angle subtended by the hole of 2 at 1. {We are assuming

$d \ll l$ so $\Delta \Omega = \text{area of hole} / (\text{distance})^2$ }.

This must equal $\sigma T_2^4 \pi d^2/4$

which is the energy emitted by 2. Thus equating

$$\frac{1}{4} \sigma d^2 T_1^4 \frac{\pi d^2}{4 l^2} = \sigma T_2^4 \frac{\pi d^2}{4}$$

or
$$T_2 = T_1 \sqrt{\frac{d}{2l}}$$

Substituting we get
$$T_2 = 0.380 \text{ kK} = 380 \text{ K.}$$

5.253 (a) The total internal energy of the cavity is

$$U = \frac{4\sigma}{c} T^4 V$$

Hence

$$\begin{aligned} C_V &= \left(\frac{\partial U}{\partial T} \right)_V = \frac{16\sigma}{C} T^3 V \\ &= \frac{16 \times 5.67 \times 10^8}{3 \times 10^8} \times 10^9 \times 10^{-3} \text{ Joule/}^\circ\text{K} \\ &= \frac{1.6 \times 5.67}{3} \text{ nJ/K} = 3.024 \text{ nJ/K} \end{aligned}$$

(b) From first law

$$\begin{aligned} T dS &= dU + p dV \\ &= V dU + U dV + \frac{U}{3} dV \quad \left(p = \frac{U}{3} \right) \\ &= V dU + \frac{4U}{3} dV \end{aligned}$$

so

$$\begin{aligned} dS &= \frac{16\sigma}{C} V T^2 dT + \frac{16\sigma}{3C} T^3 dV \\ &= d \left(\frac{16\sigma}{3C} V T^3 \right) \end{aligned}$$

Hence

$$S = \frac{16\sigma}{3C} V T^3 = \frac{1}{3} C_V = 1.008 \text{ nJ/K.}$$

5.254 We are given

$$u(\omega, T) = A \omega^3 \exp(-a\omega/T)$$

(a) Then
$$\frac{du}{d\omega} = \left(\frac{3}{\omega} - \frac{a}{T} \right) u = 0$$

so
$$\omega_{pr} = \frac{3T}{a} = \frac{6000}{7.64} \times 10^{12} \text{ s}^{-1}$$

(b) We determine the spectral distribution in wavelength.

$$-\tilde{u}(\lambda, T) d\lambda = u(\omega, T) d\omega$$

But
$$\omega = \frac{2\pi c}{\lambda} \quad \text{or} \quad \lambda = \frac{2\pi c}{\omega} = \frac{C'}{\omega}$$

so
$$d\lambda = -\frac{C'}{\omega^2} d\omega, \quad d\omega = -\frac{C'}{\lambda^2} d\lambda$$

(we have put a minus sign before $d\lambda$ to subsume just this fact $d\lambda$ is -ve where $d\omega$ is +ve.)

$$\tilde{u}(\lambda, T) = \frac{C'}{\lambda^2} u\left(\frac{C'}{\lambda}, T\right) = \frac{C'^4 A}{\lambda^5} \exp\left(-\frac{a C'}{\lambda T}\right)$$

This is maximum when

$$\frac{\partial \tilde{u}}{\partial \lambda} = 0 = \tilde{u} \left[\frac{-5}{\lambda} + \frac{a C'}{\lambda^2 T} \right]$$

or

$$\lambda_{pr} = \frac{a C'}{5 T} = \frac{2 \pi c a}{5 T} = 1.44 \mu \text{ m}$$

5.255 From Planck's formula

$$u_{\omega} = \frac{\hbar \omega^3}{\pi^2 c^3} \frac{1}{e^{\hbar \omega / k T} - 1}$$

(a) In a range $\hbar \omega \ll k T$ (long wavelength or high temperature).

$$\begin{aligned} u_{\omega} &\rightarrow \frac{\hbar \omega^3}{\pi^2 c^3} \frac{1}{\frac{\hbar \omega}{k T}} \\ &= \frac{\omega^2}{\pi^2 c^3} k T, \text{ using } e^x = 1 + x \quad \text{for small } x. \end{aligned}$$

(b) In the range $\hbar \omega \gg k T$ (high frequency or low temperature) :

$$\frac{\hbar \omega}{k T} \gg 1 \quad \text{so} \quad e^{\frac{\hbar \omega}{k T}} \gg 1$$

and

$$u_{\omega} = \frac{\hbar \omega^3}{\pi^2 c^3} e^{-\hbar \omega / k T}$$

5.256 We write

$$u_{\omega} d\omega = \tilde{u}_{\nu} d\nu \quad \text{where} \quad \omega = 2\pi\nu$$

$$\text{Then} \quad \tilde{u}_{\nu} = \frac{2\pi\hbar(2\pi\nu)^3}{\pi^2 c^3} \frac{1}{e^{2\pi\hbar\nu/kT} - 1} = \frac{16\pi^2\hbar\nu^3}{c^3} \frac{1}{e^{2\pi\hbar\nu/kT} - 1}$$

$$\text{Also} \quad -\tilde{u}(\lambda, T) d\lambda = u_{\omega} d\omega \quad \text{where} \quad \lambda = \frac{2\pi c}{\omega},$$

$$d\omega = -\frac{2\pi c}{\lambda^2} d\lambda$$

$$\tilde{u}(\lambda, T) = \frac{2\pi c}{\lambda^2} u\left(\frac{2\pi c}{\lambda}, T\right)$$

$$= \frac{2\pi c}{\lambda^2} \left(\frac{2\pi c}{\lambda}\right)^3 \frac{\hbar}{\pi^2 c^3} \frac{1}{e^{2\pi\hbar c/\lambda kT} - 1} = \frac{16\pi^2 c \hbar}{\lambda^5} \frac{1}{e^{2\pi\hbar c/\lambda kT} - 1}$$

5.257 We write the required power in terms of the radiosity by considering only the energy radiated in the given range. Then from the previous problem

$$\begin{aligned}\Delta P &= \frac{c}{4} \bar{u}(\lambda_m, T) \Delta \lambda \\ &= \frac{4\pi^2 c^2 \hbar}{\lambda_m^5} \frac{\Delta \lambda}{e^{2\pi c \hbar / k \lambda_m T} - 1}\end{aligned}$$

But

$$\lambda_m T = b$$

so

$$\Delta P = \frac{4\pi^2 c^2 \hbar}{\lambda_m^5} \frac{\Delta \lambda}{e^{2\pi c \hbar / kb} - 1} \Delta \lambda$$

Using the data

$$\begin{aligned}\frac{2\pi c \hbar}{kb} &= \frac{2\pi \times 3 \times 10^8 \times 1.05 \times 10^{-34}}{1.38 \times 10^{-23} \times 2.9 \times 10^{-3}} = 4.9643 \\ \frac{1}{e^{2\pi c \hbar / kb} - 1} &= 7.03 \times 10^{-3}\end{aligned}$$

and

$$\Delta P = 0.312 \text{ W/cm}^2$$

5.258 (a) From the curve of the function $y(x)$ we see that $y = 0.5$ when $x = 1.41$

Thus
$$\lambda = 1.41 \times \frac{0.29}{3700} \text{ cm} = 1.105 \mu\text{m}.$$

(b) At 5000 K

$$\lambda = \frac{0.29}{.5} \times 10^{-6} \text{ m} = 0.58 \mu\text{m}$$

So the visible range (0.40 to 0.70) μm corresponds to a range (0.69 to 1.31) of x .

From the curve

$$y(0.69) = 0.07$$

$$y(1.31) = 0.44$$

so the fraction is 0.37

(c) The value of x corresponding to 0.76 are

$$x_1 = 0.76 / \frac{0.29}{0.3} = 0.786 \text{ at } 3000 \text{ K}$$

$$x_2 = 0.76 / \frac{0.29}{0.5} = 1.31 \text{ at } 5000 \text{ K}$$

$$n(r) = \frac{\langle j \rangle}{c} = \frac{P\lambda}{8\pi^2 \hbar c^2 r^2} = n$$

so

$$\begin{aligned} r &= \frac{1}{2\pi c} \sqrt{\frac{P\lambda}{2\hbar n}} \\ &= \frac{1}{6\pi \times 10^8} \sqrt{\frac{10 \times 589 \times 10^{-6}}{2 \times 1.054 \times 10^{-34} \times 10^2 \times 10^6}} \\ &= \frac{10^2}{6\pi} \sqrt{\frac{5.89}{2.108}} = 8.87 \text{ metre} \end{aligned}$$

5.261 The statement made in the question is not always correct. However it is correct in certain cases, for example, when light is incident on a perfect reflector or perfect absorber.

Consider the former case. If light is incident at an angle θ and reflected at the angle θ , then momentum transferred by each photon is

$$2 \frac{h\nu}{c} \cos \theta$$

If there are $n(\nu)d\nu$ photons in frequency interval $(\nu, \nu + d\nu)$, then total momentum transferred is

$$\begin{aligned} &\int_0^{\infty} 2n(\nu) \frac{h\nu}{c} \cos \theta d\nu \\ &= \frac{2\Phi_e}{c} \cos \theta \end{aligned}$$

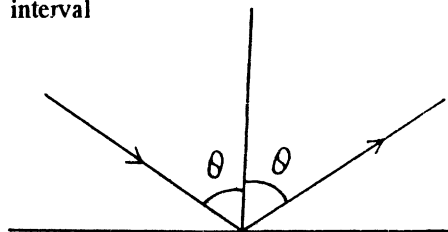

5.262 The mean pressure $\langle p \rangle$ is related to the force F exerted by the beam by

$$\langle p \rangle \times \frac{\pi d^2}{4} = F$$

The force F equals momentum transferred per second. This is (assuming that photons, not reflected, are absorbed)

$$2\rho \frac{E}{c\tau} + (1-\rho) \frac{E}{c\tau} = (1+\rho) \frac{E}{c\tau}$$

The first term is the momentum transferred on reflection (see problem (261)); the second on absorption.

$$\langle p \rangle = \frac{4(1+\rho)E}{\pi d^2 c \tau}$$

Substituting the values we get

$$\langle p \rangle = 48.3 \text{ atmosphere.}$$

5.263 The momentum transferred to the plate is

$$= \frac{E}{c} (1 - \rho) \{ \sin \theta \hat{i} - \cos \theta \hat{j} \}$$

↓
(momentum transferred
on absorption)

$$+ \frac{E}{c} \rho \{ -2 \cos \theta \hat{j} \}$$

↓
(momentum transferred
on reflection)

$$= \frac{E}{c} (1 - \rho) \sin \theta \hat{j} - \frac{E}{c} (1 + \rho) \cos \theta \hat{j} \quad (\hat{i})$$

Its magnitude is

$$\frac{E}{c} \sqrt{(1 - \rho)^2 \sin^2 \theta + (1 + \rho)^2 \cos^2 \theta} = \frac{E}{c} \sqrt{1 + \rho^2 + 2\rho \cos 2\theta}$$

Substitution gives 35 n N.s as the answer.

5.264 Suppose the mirror has a surface area A .

The incident beam then has a cross section of $A \cos \theta$ and the incident energy is $IA \cos \theta$. Then the momentum transferred per second (= Force) is from the last problem

$$- \frac{IA \cos \theta}{c} (1 + \rho) \cos \theta \hat{j} + \frac{IA \cos \theta}{c} (1 - \rho) \sin \theta \hat{i}$$

The normal pressure is then $p = \frac{I}{c} (1 + \rho) \cos^2 \theta$

(\hat{j} is the unit vector \perp to the plane mirror.)

Putting in the values

$$p = \frac{0.20 \times 10^4}{3 \times 10^8} \times 1.8 \times \frac{1}{2} = 0.6 \text{ n N cm}^{-2}$$

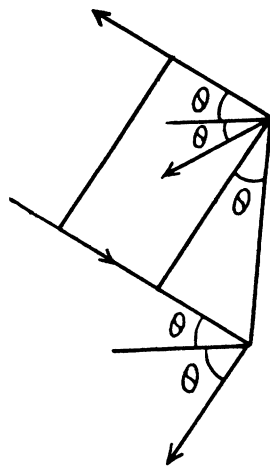
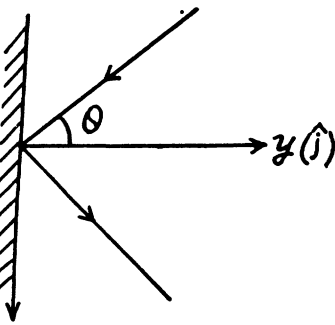

5.265 We consider a strip defined by the angular range $(\theta, \theta + d\theta)$. From the previous problem the normal pressure exerted on this strip is

$$\frac{2I}{c} \cos^2 \theta$$

This pressure gives rise to a force whose resultant, by symmetry is in the direction of the incident light. Thus

$$F = \frac{2I}{c} \int_0^{\pi/2} \cos^2 \theta \cdot \cos \theta \cdot 2\pi R^2 \sin \theta d\theta = \pi R^2 \frac{I}{c}$$

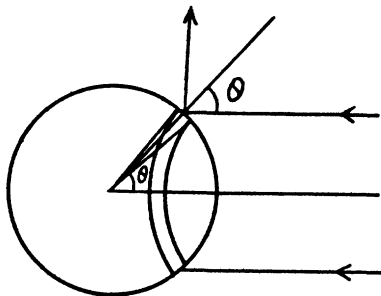

Putting in the values

$$F = \pi \times 25 \times 10^{-4} \frac{0.70 \times 10^4}{3 \times 10^8} \text{ N} = 0.183 \mu\text{N}$$

5.266 Consider a ring of radius x on the plate. The normal pressure on this ring is, by problem (264),

$$\begin{aligned} & \frac{2}{c} \frac{P}{4\pi(x^2 + \eta^2 R^2)} \cdot \cos^2 \theta \\ &= \frac{P}{2\pi c} \frac{\eta^2 R^2}{(x^2 + \eta^2 R^2)^2} \end{aligned}$$

The total force is then

$$\int_0^R \frac{P}{2\pi c} \frac{\eta^2 R^2}{(x^2 + \eta^2 R^2)^2} 2\pi x dx$$

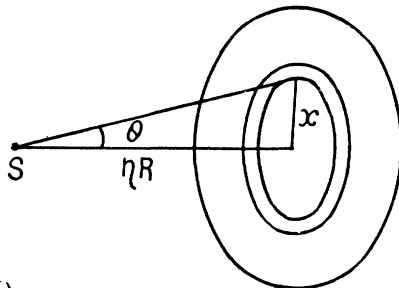

$$\begin{aligned} &= \frac{P \eta^2 R^2}{2c} \int_0^R \frac{dy}{\eta^2 R^2 + y^2} \\ &= \frac{P \eta^2 R^2}{2c} \left[\frac{1}{\eta^2 R^2} - \frac{1}{R^2(1 + \eta^2)} \right] = \frac{P}{2c(1 + \eta^2)} \end{aligned}$$

5.267 (a) In the reference frame fixed to the mirror, the frequency of the photon is, by the Doppler shift formula

$$\bar{\omega} = \omega \sqrt{\frac{1 + \beta}{1 - \beta}} \quad \left(= \omega \frac{\sqrt{1 - \beta^2}}{1 - \beta} \right).$$

(see Eqn. (5.6b) of the book.)

In this frame momentum imparted to the mirror is

$$\frac{2\hbar \bar{\omega}}{c} = \frac{2\hbar \omega}{c} \sqrt{\frac{1 + \beta}{1 - \beta}},$$

(b) In the K frame, the incident particle carries a momentum of $\hbar \omega/c$ and returns with momentum

$$\frac{\hbar \omega}{c} \frac{1 + \beta}{1 - \beta}$$

(see problem 229). The momentum imparted to the mirror, then, has the magnitude

$$\frac{\hbar \omega}{c} \left[\frac{1 + \beta}{1 - \beta} + 1 \right] = \frac{2\hbar \omega}{c} \frac{1}{1 - \beta}$$

Here

$$\beta = \frac{V}{c}.$$

5.268 When light falls on a small mirror and is reflected by it, the mirror recoils. The energy of recoil is obtained from the incident beam photon and the frequency of reflected photons is less than the frequency of the incident photons. This shift of frequency can however be neglected in calculating quantities related to recoil (to a first approximation.) Thus, the momentum acquired by the mirror as a result of the laser pulse is

$$|\vec{p}_f - \vec{p}_i| = \frac{2E}{c}$$

Or assuming $\vec{p}_i = 0$, we get

$$|\vec{p}_f| = \frac{2E}{c}$$

Hence the kinetic energy of the mirror is

$$\frac{p_f^2}{2m} = \frac{2E^2}{mc^2}$$

Suppose the mirror is deflected by an angle θ . Then by conservation of energy

$$\text{final P.E.} = mgl(1 - \cos \theta) = \text{Initial K. E.} = \frac{2E^2}{mc^2}$$

$$\text{or} \quad mgl2 \sin^2 \frac{\theta}{2} = \frac{2E^2}{mc^2}$$

$$\text{or} \quad \sin \frac{\theta}{2} = \left(\frac{E}{mc} \right) \frac{1}{\sqrt{gl}}$$

$$\text{Using the data.} \quad \sin \frac{\theta}{2} = \frac{13}{10^{-5} \times 3 \times 10^8 \sqrt{9.8 \times 1}} = 4.377 \times 10^{-3}$$

This gives $\theta = 0.502$ degrees .

5.269 We shall only consider stars which are not too compact so that the gravitational field at their surface is weak :

$$\frac{\gamma M}{c^2 R} \ll 1$$

We shall also clarify the problem by making clear the meaning of the (slightly changed) notation.

Suppose the photon is emitted by some atom whose total relativistic energies (including the rest mass) are E_1 & E_2 with $E_1 < E_2$. These energies are defined in the absence of gravitational field and we have

$$\omega_0 = \frac{E_2 - E_1}{\hbar}$$

as the frequency at infinity of the photon that is emitted in $2 \rightarrow 1$ transition. On the surface of the star, the energies have the values

$$E'_2 = E_2 - \frac{E_2}{c^2} \cdot \frac{\gamma M}{R} = E_2 \left(1 - \frac{\gamma M}{c^2 R} \right)$$

$$E'_1 = E_1 \left(1 - \frac{\gamma M}{c^2 R} \right)$$

Thus, from $\hbar \omega = E'_2 - E'_1$ we get

$$\omega = \omega_0 \left(1 - \frac{\gamma M}{c^2 R} \right)$$

Here ω is the frequency of the photon emitted in the transition $2 \rightarrow 1$ when the atom is on the surface of the star. It shows that the frequency of spectral lines emitted by atoms on the surface of some star is less than the frequency of lines emitted by atoms here on earth (where the gravitational effect is quite small).

Finally

$$\frac{\Delta \omega}{\omega_0} = - \frac{\gamma M}{c^2 R}.$$

The answer given in the book is incorrect in general though it agrees with the above result for $\frac{\gamma M}{c^2 R} \ll 1$.

5.270 The general formula is

$$\frac{2 \pi \hbar c}{\lambda} = e V$$

Thus

$$\lambda = \frac{2 \pi \hbar c}{e V}$$

Now

$$\Delta \lambda = \frac{2 \pi \hbar c}{e V} \left(1 - \frac{1}{\eta} \right)$$

Hence

$$V = \frac{2 \pi \hbar c}{e \Delta \lambda} \left(\frac{\eta - 1}{\eta} \right) = 15.9 \text{ kV}$$

5.271 We have as in the above problem

$$\frac{2 \pi \hbar c}{\lambda} = e V$$

On the other hand, from Bragg's law

$$2 d \sin \alpha = k \lambda = \lambda$$

since $k = 1$ when α takes its smallest value.

Thus

$$V = \frac{\pi \hbar c}{e d \sin \alpha} = 30.974 \text{ kV} \approx 31 \text{ kV}.$$

5.272 The wavelength of X - rays is the least when all the K.E. of the electrons approaching the anticathode is converted into the energy of X - rays.

But the K.E. of electron is

$$T_m = m c^2 \left[\frac{1}{\sqrt{1 - v^2/c^2}} - 1 \right]$$

($m c^2$ = rest mass energy of electrons = 0.511 MeV)

Thus
$$\frac{2 \pi \hbar c}{\lambda} = T_m$$

or
$$\lambda = \frac{2 \pi \hbar c}{T_m} = \frac{2 \pi \hbar}{m c} \left[\frac{1}{\sqrt{1 - v^2/c^2}} - 1 \right]^{-1}$$

$$= \frac{2 \pi \hbar}{m c (\gamma - 1)}, \quad \gamma = \frac{1}{\sqrt{1 - v^2/c^2}} = 2.70 \text{ pm.}$$

5.273 The work function of zinc is

$$A = 3.74 \text{ eV} = 3.74 \times 1.602 \times 10^{-19} \text{ Joule}$$

The threshold wavelength for photoelectric effect is given by

$$\frac{2 \pi \hbar c}{\lambda_0} = A$$

or
$$\lambda_0 = \frac{2 \pi \hbar c}{A} = 331.6 \text{ nm}$$

The maximum velocity of photoelectrons liberated by light of wavelength λ is given by

$$\frac{1}{2} m v_{\max}^2 = 2 \pi \hbar c \left(\frac{1}{\lambda} - \frac{1}{\lambda_0} \right)$$

So
$$v_{\max} = \sqrt{\frac{4 \pi \hbar c}{m} \left(\frac{1}{\lambda} - \frac{1}{\lambda_0} \right)} = 6.55 \times 10^5 \text{ m/s}$$

5.274 From the last equation of the previous problem, we find

$$\eta = \frac{(v_1)_{\max}}{(v_2)_{\max}} = \sqrt{\frac{\frac{1}{\lambda_1} - \frac{1}{\lambda_0}}{\frac{1}{\lambda_2} - \frac{1}{\lambda_0}}}$$

Thus
$$\eta^2 \left(\frac{1}{\lambda_2} - \frac{1}{\lambda_0} \right) = \frac{1}{\lambda_1} - \frac{1}{\lambda_0}$$

or
$$\frac{1}{\lambda_0} (\eta^2 - 1) = \frac{\eta^2}{\lambda_2} - \frac{1}{\lambda_1}$$

and
$$\frac{1}{\lambda_0} = \left(\frac{\eta^2}{\lambda_2} - \frac{1}{\lambda_1} \right) / (\eta^2 - 1)$$

So
$$A = \frac{2 \pi \hbar c}{\lambda_0} = \frac{2 \pi \hbar c}{\lambda_2} \frac{\eta^2 - \frac{\lambda_2}{\lambda_1}}{\eta^2 - 1} = 1.88 \text{ eV}$$

5.275 When light of sufficiently short wavelength falls on the ball, photoelectrons are ejected and the copper ball gains positive charge. The charged ball tends to resist further emission of electrons by attracting them. When the copper ball has enough charge even the most energetic electrons are unable to leave it. We can calculate this final maximum potential of the copper ball. It is obviously equal in magnitude (in volt) to the maximum K.E. of electrons (in electron volts) initially emitted. Hence

$$\begin{aligned} \phi_{\max} &= \frac{2 \pi \hbar c}{\lambda e} - A_{cu} \\ &= 8.86 - 4.47 = 4.39 \text{ volts} \end{aligned}$$

(A_{cu} is the work function of copper.)

5.276 We write

$$\begin{aligned} E &= a (1 + \cos \omega t) \cos \omega_0 t \\ &= a \cos \omega_0 t + \frac{a}{2} \left[\cos (\omega_0 - \omega) t + \cos (\omega_0 + \omega) t \right] \end{aligned}$$

It is obvious that light has three frequencies and the maximum K.E. of photo electrons ejected is

$$h (\omega + \omega_0) - A_{Li}$$

where $A_{Li} = 2.39 \text{ eV}$. Substituting we get 0.37 eV .

5.277 Suppose N photons fall on the photocell per sec. Then the power incident is

$$N \frac{2 \pi \hbar c}{\lambda}$$

This will give rise to a photocurrent of $N \frac{2 \pi \hbar c}{\lambda} \cdot J$

which means that

$$N \frac{2 \pi \hbar c}{e \lambda} \cdot J$$

electrons have been emitted. Thus the number of photoelectrons produced by each photon is

$$w = \frac{2 \pi \hbar c J}{e \lambda} = 0.0198 \approx 0.02$$

5.278 A simple application of Einstein's equation

$$\frac{1}{2} m v_{\max}^2 = h \nu - h \nu_0 = \frac{2 \pi \hbar c}{\lambda} - A_{cs}$$

gives incorrect result in this case because the photoelectrons emitted by the Cesium electrode are retarded by the small electric field that exists between the cesium electrode and the Copper electrode even in the absence of external emf. This small electric field is caused by the contact potential difference whose magnitude equals the difference of work functions

$$\frac{1}{e} (A_{cu} - A_{cs}) \text{ volts.}$$

Its physical origin is explained below.

The maximum velocity of the photoelectrons reaching the copper electrode is then

$$\frac{1}{2} m v_m^2 = \frac{1}{2} m v_0^2 - (A_{cu} - A_{cs}) = \frac{2 \pi \hbar c}{\lambda} - A_{cu}$$

Here v_0 is the maximum velocity of the photoelectrons immediately after emission. Putting the values we get, on using $A_{cu} = 4.47 \text{ eV}$, $\lambda = 0.22 \mu\text{m}$,

$$v_m = 6.41 \times 10^5 \text{ m/s}$$

The origin of contact potential difference is the following. Inside the metals free electrons can be thought of as a Fermi gas which occupy energy levels upto a maximum called the Fermi energy E_F . The work function A measures the depth of the Fermi level.

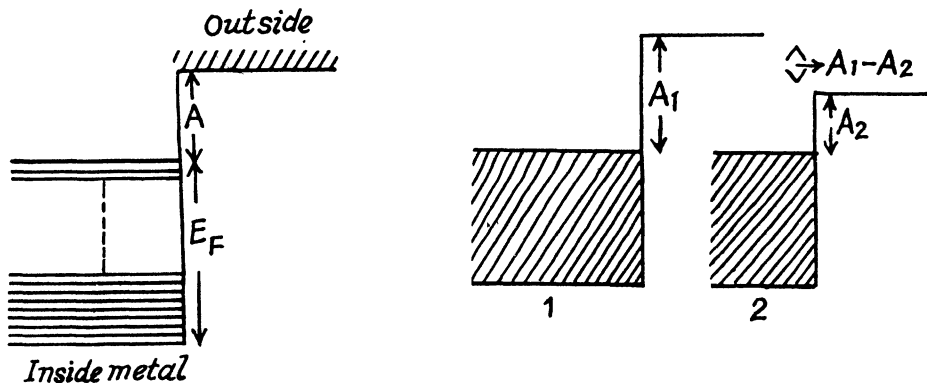

When two metals 1 & 2 are in contact, electrons flow from one to the other till their Fermi levels are the same. This requires the appearance of contact potential difference of $A_1 - A_2$ between the two metals externally.

5.279 The maximum K.E. of the photoelectrons emitted by the Zn cathode is

$$E_{\max} = \frac{2 \pi \hbar c}{\lambda} - A_{zn}$$

On calculating this comes out to be $0.993 \text{ eV} \approx 1.0 \text{ eV}$

Since an external decelerating voltage of 1.5 V is required to cancel this current, we infer that a contact potential difference of $1.5 - 1.0 = 0.5 \text{ V}$ exists in the circuit whose polarity is opposite of the decelerating voltage.

- 5.280 The unit of \hbar is Joule-sec. Since $m c^2$ is the rest mass energy, $\frac{\hbar}{m c^2}$ has the dimension of time and multiplying by c we get a quantity

$$\lambda_c = \frac{\hbar}{m c}.$$

whose dimension is length. This quantity is called reduced compton wavelength.

(The name compton wavelength is traditionally reserved for $\frac{2 \pi \hbar}{m c}$).

- 5.281 We consider the collision in the rest frame of the initial electron. Then the reaction is

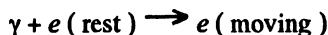

Energy momentum conservation gives

$$\begin{aligned} \hbar \omega + m_0 c^2 &= m_0 c^2 / \sqrt{1 - \beta^2} \\ \frac{\hbar \omega}{c} &= \frac{m_0 c \beta}{\sqrt{1 - \beta^2}} \end{aligned}$$

where ω is the angular frequency of the photon.

Eliminating $\hbar \omega$ we get

$$m_0 c^2 = m_0 c^2 \frac{1 - \beta}{\sqrt{1 - \beta^2}} = m_0 c^2 \sqrt{\frac{1 - \beta}{1 + \beta}}$$

This gives $\beta = 0$ which implies $\hbar \omega = 0$.

But a zero energy photon means no photon.

- 5.282 (a) Compton scattering is the scattering of light by free electrons. (The free electrons are the electrons whose binding is much smaller than the typical energy transfer to the electrons). For this reason the increase in wavelength $\Delta \lambda$ is independent of the nature of the scattered substance.
- (b) This is because the effective number of free electrons increases in both cases. With increasing angle of scattering, the energy transferred to electrons increases. With diminishing atomic number of the substance the binding energy of the electrons decreases.
- (c) The presence of a non-displaced component in the scattered radiation is due to scattering from strongly bound (inner) electrons as well as nuclei. For scattering by these the atom essentially recoils as a whole and there is very little energy transfer.

5.283 Let λ_0 = wavelength of the incident radiation.

Then

wavelength of the radiation scattered at $\theta_1 = 60^\circ$

$$= \lambda_1 = \lambda_0 + 2\pi\lambda_c(1 - \cos\theta_1) \quad \text{where } \lambda_c = \frac{h}{mc}$$

and similarly

$$\lambda_2 = \lambda_0 + 2\pi\lambda_c(1 - \cos\theta_2)$$

From the data $\theta_1 = 60^\circ$, $\theta_2 = 120^\circ$ and

$$\lambda_2 = \eta\lambda_1$$

Thus $(\eta - 1)\lambda_0 = 2\pi\lambda_c[1 - \cos\theta_2 - \eta(1 - \cos\theta_1)]$

$$= 2\pi\lambda_c[1 - \eta + \eta\cos\theta_1 - \cos\theta_2]$$

Hence

$$\lambda_0 = 2\pi\lambda_c \left[\frac{\eta\cos\theta_1 - \cos\theta_2}{\eta - 1} - 1 \right]$$

$$= 4\pi\lambda_c \left[\frac{\sin^2\theta_2/2 - \eta\sin^2\theta_1/2}{\eta - 1} \right] = 1.21 \text{ pm.}$$

The expression λ_0 given in the book contains misprints.

5.284 The wave lengths of the photon has increased by a fraction η so its final wavelength is

$$\lambda_f = (2 + \eta)\lambda_i$$

and its energy is

$$\frac{h\omega}{1 + \eta}$$

The K.E. of the compton electron is the energy lost by the photon and is

$$T = h\omega \left(1 - \frac{1}{1 + \eta} \right) = h\omega \frac{\eta}{1 + \eta}$$

5.285 (a) From the Compton formula

$$\lambda' = 2\pi\lambda_c(1 - \cos 90^\circ) + \lambda$$

Thus $\omega' = \frac{2\pi c}{\lambda'} = \frac{2\pi c}{\lambda + 2\pi\lambda_c}$ where $2\pi\lambda_c = \frac{h}{mc}$.

Substituting the values. we get $\omega' = 2.24 \times 10^{20} \text{ rad/sec}$

(b) The kinetic energy of the scattered electron (in the frame in which the initial electron was stationary) is simply

$$T = h\omega - h\omega'$$

$$\begin{aligned}
 &= \frac{2\pi\hbar c}{\lambda} - \frac{2\pi\hbar c}{\lambda + 2\pi\lambda_c} \\
 &= \frac{4\pi^2\hbar c\lambda_c}{\lambda(\lambda + 2\pi\lambda_c)} = \frac{2\pi\hbar c/\lambda}{1 + \lambda/2\pi\lambda_c} = 59.5 \text{ kV}
 \end{aligned}$$

5.286 The wave length of the incident photon is

$$\lambda_0 = \frac{2\pi c}{\omega}$$

Then the wavelength of the final photon is

$$\frac{2\pi c}{\omega} + 2\pi\lambda_c(1 - \cos\theta)$$

and the energy of the final photon is

$$\begin{aligned}
 \hbar\omega' &= \frac{2\pi\hbar c}{\frac{2\pi c}{\omega} + 2\pi\lambda_c(1 - \cos\theta)} = \frac{h\omega}{1 + \frac{h\omega}{mc^2}(1 - \cos\theta)} \\
 &= \frac{h\omega}{1 + 2\left(\frac{h\omega}{mc^2}\right)\sin^2(\theta/2)} = 144.2 \text{ kV}
 \end{aligned}$$

5.287 We use the equation $\lambda = \frac{h}{p} = \frac{2\pi\hbar}{p}$.

Then from Compton formula

$$\frac{2\pi\hbar}{p'} = \frac{2\pi\hbar}{p} + 2\pi\frac{\hbar}{mc}(1 - \cos\theta)$$

so
$$\frac{1}{p'} = \frac{1}{p} + \frac{1}{mc} \cdot 2\sin^2\theta/2$$

Hence
$$\sin^2\frac{\theta}{2} = \frac{mc}{2}\left(\frac{1}{p'} - \frac{1}{p}\right)$$

$$= \frac{mc(p-p')}{2pp'}$$

or
$$\sin\frac{\theta}{2} = \sqrt{\frac{mc(p-p')}{2pp'}}$$
,

Substituting from the data

$$\sin\frac{\theta}{2} = \sqrt{\frac{mc^2(cp - cp')}{2cp \cdot cp'}} = \sqrt{\frac{0.511(1.02 - 0.255)}{2 \times 1.02 \times 0.255}}$$

This gives $\theta = 120.2$ degrees.

5.288 From the Compton formula

$$\lambda = \lambda_0 + \frac{2\pi\hbar}{mc} (1 - \cos \theta)$$

From conservation of energy

$$\frac{2\pi\hbar c}{\lambda_0} = \frac{2\pi\hbar c}{\lambda} + T = \frac{2\pi\hbar c}{\lambda_0 + \frac{2\pi\hbar}{mc} (1 - \cos \theta)} + T$$

or

$$\frac{4\pi\hbar}{mc} \sin^2 \frac{\theta}{2} = \frac{T}{2\pi\hbar c} \lambda_0 \left(\lambda_0 + \frac{4\pi\hbar}{mc} \sin^2 \frac{\theta}{2} \right)$$

or introducing $\hbar\omega_0 = 2\pi\hbar c/\lambda_0$

$$\frac{2 \sin^2 \theta/2}{m c^2} = \frac{T}{\hbar\omega_0} \left(\frac{1}{\hbar\omega_0} + \frac{2}{m c^2} \sin^2 \frac{\theta}{2} \right)$$

Hence

$$\left(\frac{1}{\hbar\omega_0} \right)^2 + 2 \frac{1}{\hbar\omega_0} \frac{\sin^2 \frac{\theta}{2}}{m c^2} - \frac{2 \sin^2 \frac{\theta}{2}}{m c^2 T} = 0$$

$$\left(\frac{1}{\hbar\omega_0} + \frac{\sin^2 \frac{\theta}{2}}{m c^2} \right)^2 = \frac{2 \sin^2 \frac{\theta}{2}}{m c^2 T} + \left(\frac{\sin^2 \frac{\theta}{2}}{m c^2} \right)^2$$

$$\frac{1}{\hbar\omega_0} = \frac{\sin^2 \frac{\theta}{2}}{m c^2} \left[\sqrt{1 + \frac{2 m c^2}{T \sin^2 \theta/2}} - 1 \right]$$

or

$$\hbar\omega_0 = \frac{m c^2 / \sin^2 \theta/2}{\sqrt{1 + \frac{2 m c^2}{T \sin^2 \theta/2}} - 1}$$

$$= \frac{T}{2} \left[\sqrt{1 + \frac{2 m c^2}{T \sin^2 \theta/2}} + 1 \right]$$

Substituting we get

$$\hbar\omega_0 = 0.677 \text{ MeV}$$

5.289 We see from the previous problem that the electron gains the maximum K.E. when the photon is scattered backwards $\theta = 180^\circ$. Then

$$\omega_0 = \frac{m c^2 / \hbar}{\sqrt{1 + \frac{2 m c^2}{T_{\max}} - 1}}$$

Hence
$$\lambda_0 = \frac{2 \pi c}{\omega_0} = \frac{2 \pi \hbar}{m c} \left[\sqrt{1 + \frac{2 m c^2}{T_{\max}} - 1} \right]$$

Substituting the values we get $\lambda_0 = 3.695 \text{ pm}$.

5.290 Refer to the diagram. Energy momentum conservation gives

$$\frac{\hbar \omega'}{c} - \frac{\hbar \omega'}{c} \cos \theta = p \cos \varphi$$

$$\frac{\hbar \omega'}{c} \sin \theta = p \sin \varphi$$

$$\hbar \omega + m c^2 = \hbar \omega' + E$$

where $E^2 = c^2 p^2 + m^2 c^4$. we see

$$\begin{aligned} \tan \varphi &= \frac{\omega' \sin \theta}{\omega - \omega' \cos \theta} = \frac{\frac{1}{\lambda'} \sin \theta}{\frac{1}{\lambda} - \frac{1}{\lambda'} \cos \theta} \\ &= \frac{\lambda \sin \theta}{\lambda' - \lambda \cos \theta} = \frac{\sin \theta}{\frac{\Delta \lambda}{\lambda} + 2 \sin^2 \frac{\theta}{2}} \end{aligned}$$

where $\Delta \lambda = \lambda' - \lambda = 2 \pi \lambda_c (1 - \cos \theta) = 4 \pi \lambda_c \sin^2 \frac{\theta}{2}$

Hence
$$\tan \varphi = \frac{2 \sin \frac{\theta}{2} \cos \frac{\theta}{2}}{\frac{\Delta \lambda}{\lambda} + \frac{\Delta \lambda}{2 \pi \lambda_c}}$$

But
$$\sin \theta = 2 \sqrt{\frac{\Delta \lambda}{4 \pi \lambda_c}} \sqrt{1 - \frac{\Delta \lambda}{4 \pi \lambda_c}} = \frac{\Delta \lambda}{2 \pi \lambda_c} \sqrt{\frac{4 \pi \lambda_c}{\Delta \lambda} - 1}$$

Thus
$$\tan \varphi = \frac{\sqrt{\frac{4 \pi \hbar}{m c \Delta \lambda} - 1}}{1 + \frac{2 \pi \hbar}{m c \lambda}} = \frac{\sqrt{\frac{4 \pi \hbar}{m c \Delta \lambda} - 1}}{1 + \frac{\hbar \omega}{m c^2}} = 31.3^\circ$$

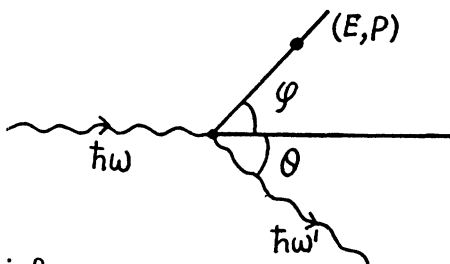

5.291 By head on collision we understand that the electron moves on in the direction of the incident photon after the collision and the photon is scattered backwards. Then, let us write

$$\hbar \omega = \eta m c^2$$

$$\hbar \omega' = \sigma m c^2$$

$$(E, p) = (\epsilon m c^2, \mu m c) \text{ of the electron.}$$

Then by energy momentum conservation (cancelling factors of $m c^2$ and $m c$)

$$1 + \eta = \sigma + \epsilon$$

$$\eta = \mu - \sigma$$

$$\epsilon^2 = 1 + \mu^2$$

So eliminating σ & ϵ

$$1 + \eta = -\eta + \mu + \sqrt{\mu^2 + 1}$$

or

$$(1 + 2\eta - \mu) = \sqrt{\mu^2 + 1}$$

Squaring

$$(1 + 2\eta)^2 - 2\mu(1 + 2\eta) = 1$$

$$4\eta + 4\eta^2 = 2\mu(1 + 2\eta)$$

or

$$\mu = \frac{2\eta(1 + \eta)}{1 + 2\eta}$$

Thus the momentum of the Compton electron is

$$p = \mu m c = \frac{2\eta(1 + \eta)m c}{1 + 2\eta}.$$

Now in a magnetic field

$$p = B e \rho$$

Thus

$$\rho = 2\eta(1 + \eta) / (1 + 2\eta) \frac{m c}{B e}.$$

Substituting the values

$$\rho = 3.412 \text{ cm.}$$

5.292 This is the inverse of usual Compton scattering.

When we write down the energy-momentum conservation equation for this process we find that they are the same for the inverse process as they are for the usual process.

It follows that the formula for Compton shift is applicable except that the energy (frequency) of the photon is increased on scattering and the wavelength is shifted downward. With this understanding, we write

$$\Delta \lambda = 2\pi \frac{\hbar}{m c} (1 - \cos \theta)$$

$$= 4\pi \left(\frac{\hbar}{m c} \right) \sin^2 \frac{\theta}{2} = 1.21 \text{ pm}$$

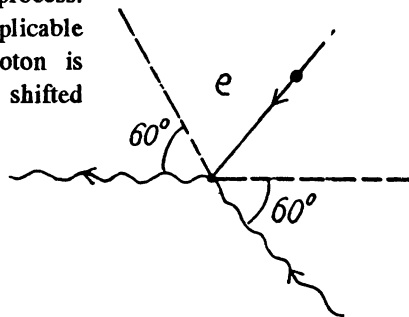

ATOMIC AND NUCLEAR PHYSICS

In this chapter the formulas in the book are given in the CGS units. Since most students are familiar only with MKS units, we shall do the problems in MKS units. However, where needed, we shall also write the formulas in the Gaussian units.

6.1 SCATTERING OF PARTICLES. RUTHERFORD-BOHR ATOM

6.1 The Thomson model consists of a uniformly charged nucleus in which the electrons are at rest at certain equilibrium points (the plum in the pudding model). For the hydrogen nucleus the charge on the nucleus is $+e$ while the charge on the electron is $-e$. The electron by symmetry must be at the centre of the nuclear charge where the potential (from problem (3.38a)) is

$$\varphi_0 = \left(\frac{1}{4\pi\epsilon_0} \right) \frac{3e}{2R}$$

where R is the radius of the nuclear charge distribution. The potential energy of the electron is $-e\varphi_0$ and since the electron is at rest, this is also the total energy. To ionize such an electron will require an energy of $E = e\varphi_0$

From this we find

$$R = \left(\frac{1}{4\pi\epsilon_0} \right) \frac{3e^2}{2E}$$

In Gaussian system the factor $\frac{1}{4\pi\epsilon_0}$ is missing.

Putting the values we get $R = 0.159 \text{ nm}$.

Light is emitted when the electron vibrates. If we displace the electron slightly inside the nucleus by giving it a push r in some radial direction and an energy δE of oscillation then since the potential at a distance r in the nucleus is

$$\varphi(r) = \left(\frac{1}{4\pi\epsilon_0} \right) \frac{e}{R} \left(\frac{3}{2} - \frac{r^2}{2R^2} \right)$$

the total energy of the nucleus becomes

$$\frac{1}{2} m \dot{r}^2 - \left(\frac{1}{4\pi\epsilon_0} \right) \frac{e^2}{R} \left(\frac{3}{2} - \frac{r^2}{2R^2} \right) = -e\varphi_0 + \delta E$$

or

$$\delta E = \frac{1}{2} m \dot{r}^2 + \left(\frac{1}{4\pi\epsilon_0} \right) \frac{e^2}{2R^3} r^2$$

This is the energy of a harmonic oscillator whose frequency is :

$$\omega^2 = \left(\frac{1}{4\pi\epsilon_0} \right) \frac{e^2}{mR^3}$$

The vibrating electron emits radiation of frequency ω whose wavelength is

$$\lambda = \frac{2\pi c}{\omega} = \frac{2\pi c}{e} \sqrt{mR^3 (4\pi\epsilon_0)^{1/2}}$$

In Gaussian units the factor $(4\pi\epsilon_0)^{1/2}$ is missing.

Putting the values we get $\lambda = 0.237 \mu\text{m}$.

6.2 Equation (6.1a) of the book reads in MKS units

$$\tan \theta/2 = \left(\frac{q_1 q_2}{4\pi\epsilon_0} \right) / 2bT$$

Thus
$$b = \left(\frac{q_1 q_2}{4\pi\epsilon_0} \right) \frac{\cot \theta/2}{2T}$$

For α particle $q_1 = 2e$, for gold $q_2 = 79e$

(In Gaussian units there is no factor $\left(\frac{1}{4\pi\epsilon_0} \right)$.)

Substituting we get $b = 0.731 \mu\text{m}$.

6.3 (a) In the Pb case we shall ignore the recoil of the nucleus both because Pb is quite heavy ($A_{\text{Pb}} = 208 = 52 \times A_{\text{He}}$) as well as because Pb is not free. Then for a head on collision, at the distance of closest approach, the K.E. of the α -particle must become zero (because α -particle will turn back at this point). Then

$$\frac{2Ze^2}{(4\pi\epsilon_0)r_{\min}} = T$$

(No $(4\pi\epsilon_0)$ in Gaussian units.). Thus putting the values

$$r_{\min} = 0.591 \mu\text{m}.$$

(b) Here we have to take account of the fact that part of the energy is spent in the recoil of Li nucleus. Suppose x_1 = coordinate of the α -particle from some arbitrary point on the line joining it to the Li nucleus, x_2 = coordinate of the Li nucleus with respect to the same point. Then we have the energy momentum equations

$$\frac{1}{2}m_1\dot{x}_1^2 + \frac{1}{2}m_2\dot{x}_2^2 + \frac{2 \times 3 e^2}{(4\pi\epsilon_0)|x_1 - x_2|} = T$$

$$m_1\dot{x}_1 + m_2\dot{x}_2 = \sqrt{2m_1T}$$

Here m_1 = mass of He^{++} nucleus, m_2 = mass of Li nucleus. Eliminating \dot{x}_2

$$T = \frac{1}{2}m_1\dot{x}_1^2 + \frac{1}{2m_2} \left(\sqrt{2m_1T} - m_1\dot{x}_1 \right)^2 + \frac{6e^2}{(4\pi\epsilon_0)(x_1 - x_2)}$$

We complete the square on the right hand side and rewrite the above equation as

$$\frac{m_2}{m_1 + m_2} T = \frac{1}{2 m_2} \left[\sqrt{m_1 (m_1 + m_2)} \dot{x}_1 - \sqrt{\frac{m_1}{m_1 + m_2}} \sqrt{2 m_1 T} \right]^2 + \frac{6 e^2}{(4 \pi \epsilon_0) |x_1 - x_2|}$$

For the least distance of approach, the second term on the right must be greatest which implies that the first term must vanish.

$$\text{Thus} \quad |x_1 - x_2|_{\min} = \frac{6 e^2}{(4 \pi \epsilon_0) T} \left(1 + \frac{m_1}{m_2} \right)$$

Using $\frac{m_1}{m_2} = \frac{4}{7}$ and other values we get

$$|x_1 - x_2|_{\min} = .034 \text{ pm} .$$

(In Gaussian units the factor $4 \pi \epsilon_0$ is absent).

6.4 We shall ignore the recoil of Hg nucleus.

(a) Let A be the point of closest approach to the centre C , $AC = r_{\min}$. At A the motion is instantaneously circular because the radial velocity vanishes. Then if v_0 is the speed of the particle at A , the following equations hold

$$\Gamma = \frac{1}{2} m v_0^2 + \frac{z_1 z_2 e^2}{(4 \pi \epsilon_0) r_{\min}} \quad (1)$$

$$m v_0 r_{\min} = \sqrt{2 m T} b \quad (2)$$

$$\frac{m v_0^2}{\rho_{\min}} = \frac{z_1 z_2 e^2}{(4 \pi \epsilon_0) r_{\min}^2} \quad (3)$$

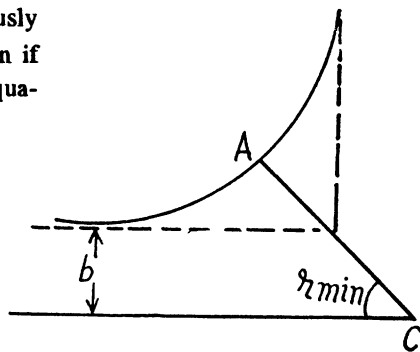

(This is Newton's law. Here $\rho = \rho_{\min}$ is the radius of curvature of the path at A and ρ is minimum at A by symmetry.) Finally we have Eqn. (6.1 a) in the form

$$b = \frac{z_1 z_2 e^2}{(4 \pi \epsilon_0) 2 T} \cot^2 \frac{\theta}{2} \quad (4)$$

From (2) and (3)

$$\frac{2 T b^2}{\rho_{\min}} = \frac{z_1 z_2 e^2}{(4 \pi \epsilon_0)}$$

or

$$\rho_{\min} = \frac{z_1 z_2 e^2}{(4 \pi \epsilon_0) 2 T} \cot^2 \frac{\theta}{2} ,$$

with

$$z_1 = 2, z_2 = 80 \text{ we get} \\ \rho_{\min} = 0.231 \text{ pm} .$$

(b) From (2) and (4) we write

$$r_{\min} = \frac{z_1 z_2 e^2}{(4\pi\epsilon_0)\sqrt{2mT}} \frac{\cot \theta/2}{v_0},$$

Substituting in (1) $T = \frac{1}{2} m v_0^2 + \sqrt{2mT} v_0 \tan \theta/2$

Solving for v_0 we get $v_0 = \sqrt{\frac{2T}{m}} \left(\sec \frac{\theta}{2} - \tan \frac{\theta}{2} \right)$

Then

$$\begin{aligned} r_{\min} &= \frac{z_1 z_2 e^2}{(4\pi\epsilon_0)2T} \frac{\cot \frac{\theta}{2}}{\sec \frac{\theta}{2} - \tan \frac{\theta}{2}} \\ &= \frac{z_1 z_2 e^2}{(4\pi\epsilon_0)2T} \cot \frac{\theta}{2} \left(\sec \frac{\theta}{2} + \tan \frac{\theta}{2} \right) \\ &= \frac{z_1 z_2 e^2}{(4\pi\epsilon_0)2T} \left(1 + \operatorname{cosec} \frac{\theta}{2} \right) = 0.557 \text{ pm.} \end{aligned}$$

6.5 By momentum conservation

$$\vec{P} + \vec{P}_i = \vec{P} + \vec{P}_f$$

(proton) (Au) (proton) (Au)

Thus the momentum transferred to the gold nucleus is clearly

$$\Delta \vec{P} = \vec{P}_f - \vec{P}_i = \vec{p} - \vec{p}'$$

Although the momentum transferred to the Au nucleus is not small, the energy associated with this recoil is quite small and its effect back on the motion of the proton can be neglected to a first approximation. Then

$$\Delta \vec{P} = \sqrt{2mT} (1 - \cos \theta) \hat{i} + \sqrt{2mT} \sin \theta \hat{j}$$

Here \hat{i} is the unit vector in the direction of the incident proton and \hat{j} is normal to it on the side on which it is scattered. Thus

$$|\Delta \vec{P}| = 2\sqrt{2mT} \sin \frac{\theta}{2}$$

Or using $\tan \theta/2 = \frac{z e^2}{(4\pi\epsilon_0)2bT}$ for the proton we get

$$|\Delta \vec{P}| = 2\sqrt{2mT} / \left(1 + \left(\frac{2bT(4\pi\epsilon_0)}{z e^2} \right)^2 \right)$$

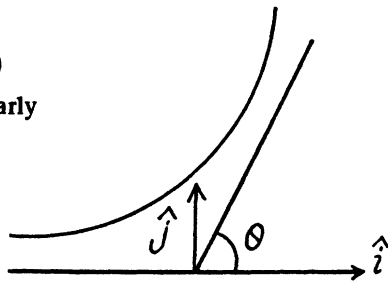

6.6 The proton moving by the electron first accelerates and then decelerates and it not easy to calculate the energy lost by the proton so energy conservation does not do the trick. Rather

we must directly calculate the momentum acquire by the electron. By symmetry that momentum is along OA and its magnitude is

$$P_d = \int F_{\perp} dt$$

where F_{\perp} is the component along OA of the force on electron. Thus

$$P_d = \int_{-\infty}^{\infty} \frac{e^2}{4\pi\epsilon_0} \frac{b}{\sqrt{b^2 + v^2 t^2}} \cdot \frac{1}{b^2 + v^2 t^2} dt$$

$$= \frac{e^2 b}{4\pi\epsilon_0 v} \int_{-\infty}^{\infty} \frac{dx}{(b^2 + x^2)^{3/2}}$$

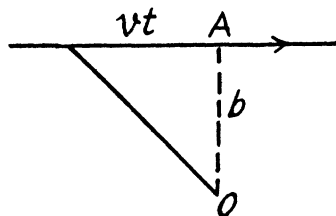

Evaluate the integral by substituting

$$x = b \tan \theta$$

Then

$$P_e = \frac{2e^2}{(4\pi\epsilon_0)vb}$$

Then

$$T_e = \frac{P_e^2}{2m_e} = \frac{m_p e^4}{(4\pi\epsilon_0)^2 T b^2 m_e}$$

In Gaussian units there is no factor $(4\pi\epsilon_0)^2$. Substituting the values we get

$$T_e = 3.82 \text{ eV.}$$

6.7 See the diagram on the next page. In the region where potential is nonzero, the kinetic energy of the particle is, by energy conservation,

$T + U_0$ and the momentum of the particle has the magnitude $\sqrt{2m(T + U_0)}$. On the boundary the force is radial, so the tangential component of the momentum does not change :

$$\sqrt{2mT} \sin \alpha = \sqrt{2m(T + U_0)} \sin \varphi$$

$$\text{so } \sin \varphi = \sqrt{\frac{T}{T + U_0}} \sin \alpha = \frac{\sin \alpha}{n}$$

where $n = \sqrt{1 + \frac{U_0}{T}}$. We also have

$$\theta = 2(\alpha - \varphi)$$

Therefore

$$\sin \frac{\theta}{2} = \sin(\alpha - \varphi) = \sin \alpha \cos \varphi - \cos \alpha \sin \varphi$$

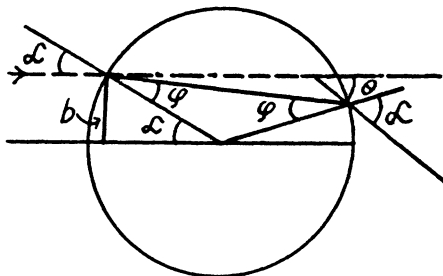

$$= \sin \alpha \left(\cos \varphi - \frac{\cos \alpha}{n} \right)$$

$$\text{or} \quad \frac{n \sin \theta/2}{\sin \alpha} = \sqrt{n^2 - \sin^2 \alpha} - \cos \alpha$$

$$\text{or} \quad \left(\frac{n \sin \theta/2}{\sin \alpha} + \cos \alpha \right)^2 = n^2 - \sin^2 \alpha$$

$$\text{or} \quad n^2 \sin^2 \frac{\theta}{2} \cot^2 \alpha + 2 n \sin \frac{\theta}{2} \cot \alpha + 1 = n^2 \cos^2 \frac{\theta}{2}$$

$$\text{or} \quad \cot \alpha = \frac{n \cos \frac{\theta}{2} - 1}{n \sin \frac{\theta}{2}}$$

$$\text{Hence} \quad \sin \alpha = \frac{n \sin \frac{\theta}{2}}{\sqrt{1 + n^2 - 2 n \cos \frac{\theta}{2}}}$$

Finally, the impact parameter is

$$b = R \sin \alpha = \frac{n R \sin \frac{\theta}{2}}{\sqrt{1 + n^2 - 2 n \cos \frac{\theta}{2}}}$$

6.8 It is implied that the ball is too heavy to recoil.

- (a) The trajectory of the particle is symmetrical about the radius vector through the point of impact. It is clear from the diagram that

$$\theta = \pi - 2\varphi \quad \text{or} \quad \varphi = \frac{\pi}{2} - \frac{\theta}{2}$$

$$\text{Also} \quad b = (R + r) \sin \varphi = (R + r) \cos \frac{\theta}{2}$$

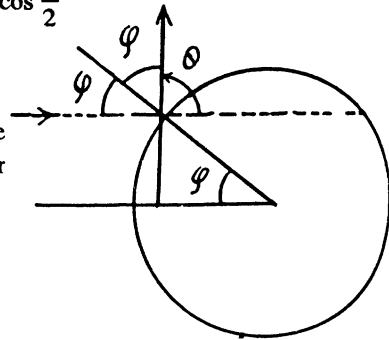

- (b) With b defined above, the fraction of particles scattered between θ and $\theta + d\theta$ (or the probability of the same) is

$$dP = \frac{|2\pi b db|}{\pi(R+r)^2} = \frac{1}{2} \sin \theta d\theta$$

- (c) This is

$$P = \int_0^{\pi/2} \frac{1}{2} \sin \theta d\theta = \frac{1}{2} \int_{-1}^0 d(-\cos \theta) = \frac{1}{2}$$

6.11 From the formula (6.1 b) of the book, we find

$$\frac{dN_{Pt}}{dN_{Ag}} = \frac{n_{Pt}}{n_{Ag}} \cdot \frac{Z_{Pt}^2}{Z_{Ag}^2} = \eta$$

But since the foils have the same mass thickness ($= \rho d$), we have

$$\frac{n_{Pt}}{n_{Ag}} = \frac{A_{Ag}}{A_{Pt}}$$

see the problem (6.9). Hence

$$Z_{Pt} = Z_{Ag} \cdot \sqrt{\frac{\eta A_{Ag}}{A_{Pt}}}$$

Substituting $Z_{Ag} = 47$, $A_{Ag} = 108$, $A_{Pt} = 195$ and $\eta = 1.52$ we get

$$Z_{Pt} = 77.86 \approx 78$$

6.12 (a) From Eqn. (6.1 b) we get

$$dN = I_0 \tau \frac{\rho d N_A}{A_{Au}} \left(\frac{Z e^2}{(4 \pi \epsilon_0) 2 T} \right)^2 \frac{2 \pi \sin \theta d \theta}{\sin^4 \theta / 2}$$

(we have used $d \Omega = 2 \pi \sin \theta d \theta$ and $N = I_0 I$)

From the data

$$d \theta = 2^\circ = \frac{2}{57.3} \text{radian}$$

Also $Z_{Au} = 79$, $A_{Au} = 197$. Putting the values we get

$$dN = 1.63 \times 10^6$$

(b) This number is

$$N(\theta_0) = I_0 \tau \left(\frac{\rho d N_A}{A_{Au}} \right) \left(\frac{Z e^2}{(4 \pi \epsilon_0) 2 T} \right)^2 4 \pi \int_{\theta_0}^{\pi} \frac{\cos \frac{\theta}{2} d \theta}{\sin^3 \frac{\theta}{2}}$$

The integral is

$$2 \int_{\sin \frac{\theta_0}{2}}^1 \frac{dx}{x^2} = \frac{1}{2} \left[\frac{-1}{2x^2} \right]_{\sin \frac{\theta_0}{2}}^1 = \cot^2 \frac{\theta_0}{2}$$

Thus

$$N(\theta_0) = \pi n d \left(\frac{Z e^2}{(4 \pi \epsilon_0) T} \right)^2 I_0 \tau \cot^2 \frac{\theta_0}{2}$$

where n is the concentration of nuclei in the foil. ($n = \rho N_1 / A_{Au}$)

Substitution gives

$$N(\theta_0) = 2.02 \times 10^7$$

- 6.13 The requisite probability can be written easily by analogy with (b) of the previous problem. It is

$$P = \frac{N(\pi/2)}{I_0 \tau} = n d \left(\frac{Z e^2}{(4 \pi \epsilon_0) 2 m v^2} \right)^2 4 \pi \int_{\pi/2}^{\pi} \frac{\cos \theta/2 d \theta}{\sin^3 \frac{\theta}{2}}$$

The integral is unity. Thus

$$P = \pi n d \left(\frac{Z e^2}{(4 \pi \epsilon_0) m v^2} \right)^2$$

Substitution gives using

$$n = \frac{\rho_{Ag} N_A}{A_{Ag}} = \frac{10.5 \times 10^3 \times 6.023 \times 10^{26}}{108}, P = .006$$

- 6.14 Because of the $\text{cosec}^4 \frac{\theta}{2}$ dependence of the scattering, the number of particles (or fraction) scattered through $\theta < \theta_0$ cannot be calculated directly. But we can write this fraction as

$$P(\theta_0) = 1 - Q(\theta_0)$$

where $Q(\theta_0)$ is the fraction of particles scattered through $\theta \geq \theta_0$. This fraction has been calculated before and is (see the results of 6.12 (b))

$$Q(\theta_0) = \pi n \left(\frac{Z e^2}{(4 \pi \epsilon_0) T} \right)^2 \cot^2 \frac{\theta_0}{2}$$

where n here is number of nuclei/cm². Using the data we get

$$Q = 0.4$$

Thus

$$P(\theta_0) = 0.6$$

- 6.15 The relevant fraction can be immediately written down (see 6.12 (b)) (Note that the projectiles are protons)

$$\frac{\Delta N}{N} = \left(\frac{e^2}{(4 \pi \epsilon_0) 2 T} \right)^2 \pi \cot^2 \frac{\theta_0}{2} \cdot (n_1 Z_1^2 + n_2 Z_2^2)$$

Here n_1 (n_2) is the number of Z_n (Cu) nuclei per cm² of the foil and Z_1 (Z_2) is the atomic number of Z_n (Cu). Now

$$n_1 = \frac{\rho d N_A}{M_1} = 0.7, n_2 = \frac{\rho d N_A}{M_2} = 0.3$$

Here M_1 , M_2 are the mass numbers of Z_n and Cu .

Then, substituting the values $Z_1 = 30$, $Z_2 = 29$, $M_1 = 65.4$, $M_2 = 63.5$, we get

$$\frac{\Delta N}{N} = 1.43 \times 10^{-3}$$

6.16 From the Rutherford scattering formula

$$\frac{d\sigma}{d\Omega} = \left(\frac{Z e^2}{(4\pi\epsilon_0) 2T} \right)^2 \frac{1}{\sin^4 \frac{\theta}{2}}$$

or

$$\begin{aligned} d\sigma &= \left(\frac{Z e^2}{(4\pi\epsilon_0) 2T} \right)^2 \frac{2\pi \sin\theta d\theta}{\sin^4 \frac{\theta}{2}} \\ &= \left(\frac{Z e^2}{(4\pi\epsilon_0) T} \right)^2 \pi \frac{\cos\theta/2 d\theta}{\sin^3 \theta/2} \end{aligned}$$

Then integrating from $\theta = \theta_0$ to $\theta = \pi$ we get the required cross section

$$\begin{aligned} \Delta\sigma &= \left(\frac{Z e^2}{(4\pi\epsilon_0) T} \right)^2 \pi \int_{\theta_0}^{\pi} \frac{\cos\theta/2 d\theta}{\sin^3 \frac{\theta}{2}} \\ &= \left(\frac{Z e^2}{(4\pi\epsilon_0) 2T} \right)^2 \cot^2 \frac{\theta_0}{2}. \end{aligned}$$

For U nucleus $Z = 92$ and we get on putting the values

$$\Delta\sigma = 737 \text{ b} = 0.737 \text{ kb.}$$

$$(1 \text{ b} = 1 \text{ barn} = 10^{-28} \text{ m}^2).$$

6.17 (a) From the previous formula

$$\Delta\sigma = \left(\frac{Z e^2}{(4\pi\epsilon_0) 2T} \right)^2 \pi \cot^2 \frac{\theta_0}{2}$$

or

$$T = \frac{Z e^2}{4\pi\epsilon_0} \cot \frac{\theta_0}{2} \sqrt{\frac{\pi}{\Delta\sigma}}$$

Substituting the values with $Z = 79$ we get ($\theta_0 = 90^\circ$)

$$T = 0.903 \text{ MeV}$$

(b) The differential scattering cross section is

$$\frac{d\sigma}{d\Omega} = C \operatorname{cosec}^4 \frac{\theta}{2}$$

where

$$\Delta\sigma(\theta > \theta_0) = 4\pi C \cot^2 \frac{\theta_0}{2}$$

Thus from the given data

$$C = \frac{500}{4\pi} \text{ b} = 39.79 \text{ b/sr}$$

So
$$\frac{d\sigma}{d\Omega}(\theta = 60^\circ) = 39.79 \times 16 \text{ b/sr} = 0.637 \text{ kb/sr}.$$

6.18 The formula in MKS units is

$$\frac{dE}{dt} = -\frac{\mu_0 e^2}{6\pi c} \vec{w}^2$$

For an electron performing (linear) harmonic vibrations \vec{w} is in some definite directions with

$$w_x = -\omega^2 x \text{ say.}$$

Thus
$$\frac{dE}{dt} = -\frac{\mu_0 e^2 \omega^4}{6\pi c} x^2$$

If the radiation loss is small (i.e. if ω is not too large), then the motion of the electron is always close to simple harmonic with slowly decreasing amplitude. Then we can write

$$E = \frac{1}{2} m \omega^2 a^2$$

and

$$x = a \cos \omega t$$

and average the above equation ignoring the variation of a in any cycle. Thus we get the equation, on using $\langle x^2 \rangle = \frac{1}{2} a^2$

$$\frac{dE}{dt} = -\frac{\mu_0 e^2 \omega^4}{6\pi c} \cdot \frac{1}{2} a^2 = -\frac{\mu_0 e^2 \omega^2}{6\pi m c} E$$

since $E = \frac{1}{2} m \omega^2 a^2$ for a harmonic oscillator.

This equation integrates to

$$E = E_0 e^{-t/T}$$

where

$$T = 6\pi m c / e^2 \omega^2 \mu_0.$$

It is then seen that energy decreases η times in

$$t_0 = T \ln \eta = \frac{6\pi m c}{e^2 \omega^2 \mu_0} \ln \eta = 14.7 \text{ ns.}$$

6.19 Moving around the nucleus, the electron radiates and its energy decreases. This means that the electron gets nearer the nucleus. By the statement of the problem we can assume that the electron is always moving in a circular orbit and the radial acceleration by Newton's law is

$$w = \frac{e^2}{(4\pi\epsilon_0) m r^2}$$

directed inwards. Thus

$$\frac{dE}{dt} = -\frac{\mu_0 e^6}{6\pi c} \frac{1}{(4\pi\epsilon_0)^2 m^2 r^4}$$

On the other hand in a circular orbit

$$E = -\frac{e^2}{(4\pi\epsilon_0)2r}$$

so

$$\frac{e^2}{(4\pi\epsilon_0)2r^2} \frac{dr}{dt} = -\frac{\mu_0 e^6}{(4\pi\epsilon_0)^2 6\pi c m^2 r^4}$$

or

$$\frac{dr}{dt} = -\frac{\mu_0 e^4}{(4\pi\epsilon_0)3\pi c m^2 r^2}$$

Integrating

$$r^3 = r_0^3 - \frac{\mu_0 e^4}{4\pi^2 \epsilon_0 c m^2} t$$

and the radius falls to zero in

$$t_0 = \frac{4\pi^2 \epsilon_0 c m^2 r_0^3}{\mu_0 e^4} \text{ sec.} = 13.1 \text{ ps.}$$

6.20 In a circular orbit we have the following formula

$$\frac{m v^2}{r} = \frac{Z e^2}{(4\pi\epsilon_0) r^2}$$

$$m v r = n \hbar$$

Then

$$v = \frac{Z e^2}{(4\pi\epsilon_0) n \hbar}$$

$$r = \frac{n^2 \hbar (4\pi\epsilon_0)}{Z m e^2}$$

The energy E is

$$E_n = \frac{1}{2} m v^2 - \frac{Z e^2}{(4\pi\epsilon_0) r}$$

$$= \left(\frac{Z e^2}{4\pi\epsilon_0} \right)^2 \frac{m}{2 \hbar^2 n^2} - \left(\frac{Z e^2}{4\pi\epsilon_0} \right)^2 \frac{m}{\hbar^2 n^2} = m \left(\frac{Z e^2}{4\pi\epsilon_0} \right)^2 / 2 \hbar^2 n^2$$

and the circular frequency of this orbit is

$$\omega_n = \frac{v}{r} = \left(\frac{Z e^2}{4\pi\epsilon_0} \right)^2 m / \hbar^3 n^3$$

On the other hand the frequency ω of the light emitted when the electron makes a transition $n+1 \rightarrow n$ is

$$\omega = \left(\frac{Z e^2}{4\pi\epsilon_0} \right)^2 \frac{m}{2 \hbar^2} \left(\frac{1}{n^2} - \frac{1}{(n+1)^2} \right)$$

Thus the inequality

$$\omega_n > \omega > \omega_{n+1}$$

will result if

$$\frac{1}{n^3} > \frac{1}{2} \left(\frac{1}{n^2} - \frac{1}{(n+1)^2} \right) > \frac{1}{(n+1)^3}$$

Or multiplying by $n^2 (n+1)^2$ we have to prove

$$\frac{(n+1)^2}{n} > \frac{1}{2} (2n+1) > \frac{n^2}{n+1}$$

This can be written as

$$n+2 + \frac{1}{n} > n + \frac{1}{2} > n+1 - 2 + \frac{1}{n+1}$$

This is obvious because $-1 + \frac{1}{n+1} < -\frac{1}{2}$ since $n \geq 1$

For large n

$$\frac{\omega_n}{\omega_{n+1}} = \left(\frac{n+1}{n} \right)^3 = 1 + \frac{3}{n}$$

so $\frac{\omega_n}{\omega_{n+1}} \rightarrow 1$ and we may say $\frac{\omega}{\omega_n} \rightarrow 1$

6.21 We have the following equation (we ignore reduced mass effects)

$$\frac{m v^2}{r} = k r$$

$$m v r = n \hbar$$

so

$$m \bar{v} = \sqrt{m k r}$$

and

$$r = \sqrt{\frac{n \hbar}{\sqrt{m k}}}$$

and

$$v = \sqrt{n \hbar \sqrt{m k}} / m$$

The energy levels are

$$\begin{aligned} E_n &= \frac{1}{2} m v^2 + \frac{1}{2} k r^2 \\ &= \frac{1}{2} \frac{n \hbar \sqrt{m k}}{m} + \frac{1}{2} k \frac{n \hbar}{\sqrt{m k}} \\ &= n \hbar \sqrt{\frac{k}{m}} \end{aligned}$$

6.22 The basic equations have been derived in the problem (6.20). We rewrite them here and determine the the required values.

$$(a) \quad r_1 = \frac{\hbar^2}{m (Z e^2 / 4 \pi \epsilon_0)}, \quad Z = 1 \text{ for H, } Z = 2 \text{ for He}^+$$

$$\text{Thus} \quad r_1 = 52.8 \text{ pm, for H atom}$$

$$r_1 = 26.4 \text{ pm, for He}^+ \text{ ion}$$

$$v_1 = \frac{Z e^2}{(4 \pi \epsilon_0) \hbar}$$

$$v_1 = 2.191 \times 10^6 \text{ m/s for H atom}$$

$$= 4.382 \times 10^6 \text{ m/s for He}^+ \text{ ion}$$

$$(b) \quad T = \frac{1}{2} m v_1^2 = \frac{m (Z e^2)^2}{(4 \pi \epsilon_0)^2 2 \hbar^2}$$

$$T = 13.65 \text{ eV for H atom}$$

$$T = 54.6 \text{ eV for He}^+ \text{ ion}$$

In both cases $E_b = T$ because $E_b = -E$ and $E = -T$ (Recall that for coulomb force $V = -2T$)

(c) The ionization potential φ_i is given by

$$e \varphi_i = E_b$$

$$\text{so} \quad \varphi_i = 13.65 \text{ volts for H atom}$$

$$\varphi_i = 54.6 \text{ volts for He}^+ \text{ ion}$$

$$\text{The energy levels are} \quad E_n = -\frac{13.65}{n^2} \text{ eV for H atom}$$

$$\text{and} \quad E_n = -\frac{54.6}{n^2} \text{ eV for He}^+ \text{ ion}$$

$$\text{Thus} \quad \varphi_1 = 13.65 \left(1 - \frac{1}{4}\right) \text{ volts} = 10.23 \text{ volts for H atom}$$

$$\varphi_1 = 4 \times 10.23 = 40.9 \text{ volts for He}^+ \text{ ion}$$

The wavelength of the resonance line

($n' = 2 \rightarrow n = 1$) is given by

$$\frac{2 \pi \hbar c}{\lambda} = -\frac{13.6}{4} + \frac{13.6}{1} = 10.23 \text{ eV for H atom}$$

$$\text{so} \quad \lambda = 121.2 \text{ nm for H atom}$$

$$\text{For He}^+ \text{ ion} \quad \lambda = \frac{121.2}{4} = 30.3 \text{ nm}.$$

6.23 This has been calculated before in problem (6.20). It is

$$\omega = \frac{m (Z e^2 / 4 \pi \epsilon_0)^2}{\hbar^3 n^3} = 2.08 \times 10^{16} \text{ rad/sec}$$

6.24 An electron moving in a circle with a time period T constitutes a current

$$I = \frac{e}{T}$$

and forms a current loop of area πr^2 . This is equivalent to magnetic moment,

$$\mu = I \pi r^2 = \frac{e \pi r^2}{T} = \frac{e v r}{2}$$

on using $v = 2 \pi r / T$. Thus

$$\mu_n = \frac{e m v r}{2 m} = \frac{n e \hbar}{2 m}$$

for the n^{th} orbit. (In Gaussian units

$$\mu_n = n e \hbar / 2 m c)$$

We see that

$$\mu_n = \frac{e}{2 m} M_n$$

where $M_n = n \hbar = m v r$ is the angular momentum

Thus

$$\frac{\mu_n}{M_n} = \frac{e}{2 m}$$

$$\mu_1 = \frac{e \hbar}{2 m} = \mu_B = 9.27 \times 10^{-24} \text{ A}\cdot\text{m}^2$$

(In CGS units $\mu_1 = \mu_B = 9.27 \times 10^{-21}$ erg/gauss)

6.25 The revolving electron is equivalent to a circular current

$$I = \frac{e}{T} = \frac{e}{2 \pi r / v} = \frac{e v}{2 \pi r}$$

The magnetic induction

$$\begin{aligned} B &= \frac{\mu_0 I}{2 r} = \frac{\mu_0 e v}{4 \pi r^2} = \frac{\mu_0}{4 \pi} \cdot e \cdot \frac{e^2}{(4 \pi \epsilon_0) \hbar} \cdot \left[\frac{m e^2}{\hbar^2 (4 \pi \epsilon_0)} \right]^2 \\ &= \frac{\mu_0 m^2 e^7}{256 \pi^4 \epsilon_0^3 \hbar^5} \end{aligned}$$

Substitution gives $B = 12.56 \text{ T}$ at the centre.

(In Gaussian units

$$B = \frac{m^2 e^7}{c \hbar^5} = 125.6 \text{ k G.})$$

6.26 From the general formula for the transition $n_2 \rightarrow n_1$

$$\hbar \omega = E_H \left(\frac{1}{n_1^2} - \frac{1}{n_2^2} \right)$$

where

$$E_H = 13.65 \text{ eV}. \text{ Then}$$

(1) Lyman, $n_1 = 1$, $n_2 = 2, 3$. Thus

$$\hbar \omega \geq \frac{3}{4} E_H = 10.238 \text{ eV}$$

This corresponds to $\lambda = \frac{2\pi c \hbar}{\hbar \omega} = 0.121 \mu\text{m}$

and Lyman lines have $\lambda \leq 0.121 \mu\text{m}$ with the series limit at $0.0909 \mu\text{m}$

(2) Balmer : $n_2 = 2$, $n_3 = 3, 4$,

$$\hbar \omega \geq E_H \left(\frac{1}{4} - \frac{1}{9} \right) = \frac{5}{36} E_H = 1.876 \text{ eV}$$

This corresponds to

$$\lambda = 0.65 \mu\text{m}$$

and Balmer series has $\lambda \leq 0.65 \mu\text{m}$ with the series limit at $\lambda = 0.363 \mu\text{m}$.

(3) Paschen : $n_2 = 3$, $n_1 = 4, 5, \dots$

$$\hbar \omega \geq E_H \left(\frac{1}{9} - \frac{1}{16} \right) = \frac{7}{144} E_H = 0.6635 \text{ eV}$$

This corresponds to $\lambda = 1.869 \mu\text{m}$

with the series limit at $\lambda = 0.818 \mu\text{m}$

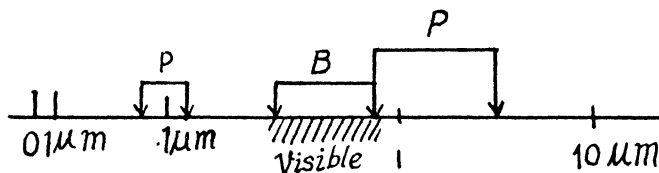

6.27 The Balmer line of wavelength 486.1 nm is due to the transition $4 \rightarrow 2$ while the Balmer line of wavelength 410.2 nm is due to the transition $6 \rightarrow 2$. The line whose wave number corresponds to the difference in wave numbers of these two lines is due to the transition $6 \rightarrow 4$. That line belongs to the Brackett series. The wavelength of this line is

$$\lambda = \frac{1}{\frac{1}{\lambda_2} - \frac{1}{\lambda_1}} = \frac{\lambda_1 \lambda_2}{\lambda_1 - \lambda_2} = 2.627 \mu\text{m}$$

6.28 The energies are

$$E_H \left(\frac{1}{4} - \frac{1}{9} \right) = \frac{5}{36} E_H, \quad E_H \left(\frac{1}{4} - \frac{1}{16} \right) = \frac{3}{16} E_H$$

$$E_H \left(\frac{1}{4} - \frac{1}{25} \right) = \frac{21}{100} E_H$$

They correspond to wavelengths

$$654.2 \text{ nm}, \quad 484.6 \text{ nm} \quad \text{and} \quad 433 \text{ nm}$$

The n^{th} line of the Balmer series has the energy

$$E_H \left(\frac{1}{4} - \frac{1}{(n+2)^2} \right)$$

For $n = 19$, we get the wavelength 366.7450 nm

For $n = 20$ we get the wavelength 366.4470 nm

To resolve these lines we require a resolving power of

$$R \approx \frac{\lambda}{\delta \lambda} = \frac{366.6}{0.298} = 1.23 \times 10^3$$

6.29 For the Balmer series

$$\hbar \omega_n = \hbar R \left(\frac{1}{4} - \frac{2}{n^2} \right), \quad n \geq 3,$$

where $\hbar R = E_H = 13.65 \text{ eV}$. Thus

$$\frac{2 \pi \hbar c}{\lambda_n} = \hbar R \left(\frac{1}{4} - \frac{1}{n^2} \right)$$

or

$$\frac{2 \pi \hbar c}{\lambda_{n+1}} - \frac{2 \pi \hbar c}{\lambda_n} = \hbar R \left(\frac{1}{n^2} - \frac{1}{(n+1)^2} \right)$$

$$= \hbar R \left(\frac{2n+1}{n^2(n+1)^2} \right) \approx \frac{2R}{n^3} \text{ for } n \gg 1$$

Thus

$$\frac{2 \pi \hbar c}{\lambda_n^2} \delta \lambda \approx \frac{2R\hbar}{n^3}$$

or

$$\frac{\lambda_n}{\delta \lambda} \approx \frac{\pi \hbar c n^3}{\lambda_n R \hbar} = \frac{\pi c n^3}{\lambda_n R}$$

On the other hand for just resolution in a diffraction grating

$$\frac{\lambda}{\delta \lambda} = kN = k \frac{l}{d} = \frac{l}{\lambda d} k \lambda = \frac{l}{\lambda d} d \sin \theta = \frac{l}{\lambda} \sin \theta$$

Hence

$$\sin \theta = \frac{\pi c n^3}{l R}$$

Substitution gives $\theta \approx 59.4^\circ$.

- 6.30 If all wavelengths are four times shorter but otherwise similar to the hydrogen atom spectrum then the energy levels of the given atom must be four times greater.

This means
$$E_n = -\frac{4E_H}{n^2}$$

compared to $E_n = -\frac{E_H}{n^2}$ for hydrogen atom. Therefore the spectrum is that of He⁺ ion ($Z = 2$).

- 6.31 Because of cascading all possible transitions are seen. Thus we look for the number of ways in which we can select upper and lower levels. The number of ways we can do this is

$$\frac{1}{2}n(n-1)$$

where the factor $\frac{1}{2}$ takes account of the fact that the photon emission always arises from upper \rightarrow lower transition.

- 6.32 These are the Lyman lines

$$\hbar\omega = E_H \left(\frac{1}{1} - \frac{1}{n^2} \right) \quad n = 2, 3, 4, \dots$$

For $n = 2$ we get $\lambda = 121.1 \text{ nm}$

For $n = 3$ we get $\lambda = 102.2 \text{ nm}$

For $n = 4$ we get $\lambda = 96.9 \text{ nm}$

For $n = 5$ we get $\lambda = 94.64 \text{ nm}$

For $n = 6$ we get $\lambda = 93.45 \text{ nm}$

Thus at the level of accuracy of our calculation, there are four lines

121.1 nm, 102.2 nm, 96.9 nm and 94.64 nm.

- 6.33 If the wavelengths are λ_1 , λ_2 then the total energy of the excited state must be

$$E_n = E_1 + \frac{2\pi c \hbar}{\lambda_1} + \frac{2\pi c \hbar}{\lambda_2}$$

But $E_1 = -4E_H$ and $E_n = -\frac{4E_H}{n^2}$ where we are ignoring reduced mass effects.

Then
$$4E_H = \frac{4E_H}{n^2} + \frac{2\pi c \hbar}{\lambda_1} + \frac{2\pi c \hbar}{\lambda_2}$$

Substituting the values we get $n^2 = 23$

which we take to mean $n = 5$. (The result is sensitive to the values of the various quantities and small differences get multiplied because difference of two large quantities is involved :

$$n^2 = \frac{E_H}{E_H - \frac{\pi c \hbar}{2} \left(\frac{1}{\lambda_1} + \frac{1}{\lambda_2} \right)}$$

6.34 For the longest wavelength (first) line of the Balmer series we have on using the generalized Balmer formula

$$\omega = Z^2 R \left(\frac{1}{n^2} - \frac{1}{m^2} \right)$$

the result

$$\lambda_{1\text{Lyman}} = \frac{2\pi c}{Z^2 R \left(1 - \frac{1}{4} \right)} = \frac{8\pi c}{3Z^2 R}$$

Then

$$\Delta\lambda = \lambda_{1\text{Balmer}} - \lambda_{1\text{Lyman}} = \frac{176\pi c}{15Z^2 R}$$

so

$$R = \frac{176\pi c}{15Z^2 \Delta\lambda} = 2.07 \times 10^{16} \text{ sec}^{-1}$$

6.35 From the formula of the previous problem

$$\Delta\lambda = \frac{176\pi c}{15Z^2 R}$$

or

$$Z = \sqrt{\frac{176\pi c}{15R\Delta\lambda}}$$

Substitution of $\Delta\lambda = 59.3 \text{ nm}$ and R and the previous problem gives $Z = 3$

This identifies the ion as Li^{++}

6.36 We start from the generalized Balmer formula

$$\omega = RZ^2 \left(\frac{1}{n^2} - \frac{1}{m^2} \right)$$

Here

$$m = n+1, n+2, \dots, \infty$$

The interval between extreme lines of this series (series n) is

$$\Delta\omega = RZ^2 \left(\frac{1}{n^2} - \frac{1}{(\infty)^2} \right) - RZ^2 \left(\frac{1}{n^2} - \frac{1}{(n+1)^2} \right) = RZ^2 / (n+1)^2$$

Hence

$$n = Z \sqrt{\frac{R}{\Delta\omega}} - 1$$

Then the angular frequency of the first line of this series (series n) is

$$\begin{aligned} \omega_1 &= RZ^2 \left(\frac{1}{n^2} - \frac{1}{(n+1)^2} \right) = \Delta\omega \left(\left(\frac{n+1}{n} \right)^2 - 1 \right) \\ &= \Delta\omega \left[\left\{ \frac{Z \sqrt{\frac{R}{\Delta\omega}}}{Z \sqrt{\frac{R}{\Delta\omega}} - 1} \right\}^2 - 1 \right] = \Delta\omega \frac{2Z \sqrt{\frac{R}{\Delta\omega}} - 1}{\left(Z \sqrt{\frac{R}{\Delta\omega}} - 1 \right)^2} \end{aligned}$$

Then the wavelength will be

$$\lambda_1 = \frac{2\pi c}{\omega_1} = \frac{2\pi c}{\Delta\omega} \frac{\left(Z\sqrt{\frac{R}{\Delta\omega}} - 1 \right)^2}{2Z\sqrt{\frac{R}{\Delta\omega}} - 1}$$

Substitution (with the value of R from problem 6.34 which is also the correct value determined directly) gives

$$\lambda_1 = 0.468 \mu\text{m}.$$

6.37 For the third line of Balmer series

$$\omega = RZ^2 \left(\frac{1}{2^2} - \frac{1}{5^2} \right) = \frac{21}{100} RZ^2$$

Hence

$$\lambda = \frac{2\pi c}{\omega} = \frac{200\pi c}{21RZ^2}$$

or

$$Z = \sqrt{\frac{200\pi c}{21R\lambda}}$$

Substitution gives $Z = 2$. Hence the binding energy of the electron in the ground state of this ion is

$$E_b = 4E_H = 4 \times 13.65 = 54.6 \text{ eV}$$

The ion is He^+ .

6.38 To remove one electron requires 24.6 eV.

The ion that is left is He^+ which in its ground state has a binding energy of $4E_H = 4\hbar R$.

The complete binding energy of both electrons is then

$$E = E_0 + 4\hbar R$$

Substitution gives

$$E = 79.1 \text{ eV}$$

6.39 By conservation of energy

$$\frac{1}{2} m v^2 = \frac{2\pi\hbar c}{\lambda} - E_b$$

where $E_b = 4\hbar R$ is the binding energy of the electron in the ground state of He^+ . (Recoil of He^{++} nucleus is neglected). Then

$$v = \sqrt{\frac{2}{m} \left(\frac{2\pi\hbar c}{\lambda} - E_b \right)}$$

Substitution gives

$$v = 2.25 \times 10^6 \text{ m/s}$$

6.40 Photon can be emitted in $H-H$ collision only if one of the H is excited to an $n = 2$ state which then decays to $n = 1$ state by emitting a photon. Let v_1 and v_2 be the velocities of the two Hydrogen atoms after the collision and M their masses. Then, energy momentum conservation

$$M v_1 + M v_2 = \sqrt{2 M T}$$

(in the frame of the stationary H atom)

$$\frac{1}{2} M v_1^2 + \frac{1}{2} M v_2^2 + \frac{3}{4} \hbar R = T$$

$\frac{3}{4} \hbar R = \hbar R \left(1 - \frac{1}{4}\right)$ is the excitation energy of the $n = 2$ state from the ground state.

Eliminating v_2
$$\frac{1}{2} M \left\{ v_1^2 + \left(\sqrt{\frac{2T}{M}} - v_1 \right)^2 \right\} + \frac{3}{4} \hbar R = T$$

or
$$\frac{1}{2} M \left\{ 2v_1^2 - 2\sqrt{\frac{2T}{M}} v_1 + \frac{2T}{M} \right\} + \frac{3}{4} \hbar R = T$$

$$M \left\{ \left(v_1 - \frac{1}{2} \sqrt{\frac{2T}{M}} \right)^2 \right\} + \frac{1}{2} T + \frac{3}{4} \hbar R = T$$

or
$$M \left\{ \left(v_1 - \frac{1}{2} \sqrt{\frac{2T}{M}} \right)^2 \right\} + \frac{3}{4} \hbar R = \frac{1}{2} T$$

For minimum T , the square on the left should vanish. Thus $T = \frac{3}{2} \hbar R = 20.4 \text{ eV}$

6.41 In the rest frame of the original excited nucleus we have the equations $0 = \vec{p}_\gamma + \vec{p}_H$

$$\frac{3}{4} \hbar R = c |\vec{p}_\gamma| + p_H^2 / 2M$$

$\left(\frac{3}{4} \hbar R\right)$ is the energy available in $n = 2 \rightarrow 1$ transition corresponding to the first Lyman line.)

Then
$$p_H^2 + 2M c p_H - \frac{3 \hbar R M}{2} = 0$$

or
$$(p_H + M c)^2 = M^2 c^2 + \frac{3}{2} \hbar R M$$

$$p_H = -M c + \sqrt{M^2 c^2 + \frac{3}{2} \hbar R M} = -M c + M c \left(1 + \frac{3 \hbar R}{2 M c^2}\right)^{1/2} \approx \frac{3 \hbar R}{4 c}$$

(We could have written this directly by noting that $p_H^2 / 2M \ll c p_\gamma$.) Then

$$v_H = \frac{3 \hbar R}{4 M c} = 3.3 \text{ m/s}$$

6.42 We have

$$\epsilon = \frac{3}{4}\hbar R \quad \text{and} \quad \epsilon' = \frac{3}{4}\hbar R - \frac{1}{2M} \left(\frac{3}{4}\hbar R/c \right)^2$$

Then
$$\frac{\epsilon - \epsilon'}{\epsilon} = \frac{3\hbar R}{8Mc^2} = \frac{v_H}{2c} = 5.5 \times 10^{-9} = 0.55 \times 10^{-6} \%$$

6.43 We neglect recoil effects. The energy of the first Lyman line photon emitted by He^+ is

$$4\hbar R \left(1 - \frac{1}{4} \right) = 3\hbar R$$

The velocity v of the photoelectron that this photon liberates is given by

$$3\hbar R = \frac{1}{2}mv^2 + \hbar R$$

where $\hbar R$ on the right is the binding energy of the $n = 1$ electron in H atom. Thus

$$v = \sqrt{\frac{4\hbar R}{m}} = 2\sqrt{\frac{\hbar R}{m}} = 3.1 \times 10^6 \text{ m/s}$$

Here m is the mass of the electron.

6.44 Since $\Delta\lambda (= 0.20 \text{ nm}) \ll \lambda (= 121 \text{ nm})$ of the first Lyman line of H atom, we need not worry about v^2/c^2 effects. Then

$$\omega' = \frac{\omega}{1 - \beta \cos \theta}, \quad \beta = \frac{v}{c}$$

Hence
$$1 - \beta \cos \theta = \frac{\omega}{\omega'} = \frac{\lambda'}{\lambda}$$

or
$$\beta \cos \theta = 1 - \frac{\lambda'}{\lambda} = \frac{\Delta\lambda}{\lambda}$$

But
$$\omega = \frac{3}{4}R \quad \text{so} \quad \lambda = \frac{2\pi c}{\omega} = \frac{8\pi c}{3R}$$

Hence
$$v = c\beta = \frac{3R\Delta\lambda}{8\pi \cos \theta}$$

Substitution gives
$$\left(\cos \theta = \frac{1}{\sqrt{2}} \right)$$

$$v = 7.0 \times 10^5 \text{ m/s}$$

6.45 (a) If we measure energy from the bottom of the well, then $V(x) = 0$ inside the walls. Then

the quantization condition reads
$$\oint p dx = 2lp = 2\pi n\hbar$$

or
$$p = \pi n\hbar/l$$

Hence
$$E_n = \frac{p^2}{2m} = \frac{\pi^2 n^2 \hbar^2}{2ml^2}$$

$\oint p dx = 2lp$ because we have to consider the integral from $-\frac{l}{2}$ to $\frac{l}{2}$ and then back to $-\frac{l}{2}$.)

(b) Here $\oint p dx = 2\pi r p = 2\pi n\hbar$

or
$$p = \frac{n\hbar}{r}$$

Hence
$$E_n = \frac{n^2\hbar^2}{2mr^2}$$

(c) By energy conservation
$$\frac{p^2}{2m} + \frac{1}{2}\alpha x^2 = E$$

so
$$p = \sqrt{2mE - m\alpha x^2}$$

Then
$$\begin{aligned} \oint p dx &= \oint \sqrt{2mE - m\alpha x^2} dx \\ &= 2\sqrt{m\alpha} \int_{-\frac{\sqrt{2E}}{\alpha}}^{\frac{\sqrt{2E}}{\alpha}} \sqrt{\frac{2E}{\alpha} - x^2} dx \end{aligned}$$

The integral is
$$\begin{aligned} \int_{-a}^a \sqrt{a^2 - x^2} dx &= a^2 \int_{-\pi/2}^{\pi/2} \cos^2 \theta d\theta \\ &= \frac{a^2}{2} \int_{-\pi/2}^{\pi/2} (1 + \cos 2\theta) d\theta = a^2 \frac{\pi}{2}. \end{aligned}$$

Thus
$$\oint p dx = \pi\sqrt{m\alpha} \cdot \frac{2E}{\alpha} = E \cdot 2\pi \cdot \sqrt{\frac{m}{\alpha}} = 2\pi n\hbar$$

Hence
$$E_n = n\hbar \sqrt{\frac{\alpha}{m}}.$$

(b) It is required to find the energy levels of the circular orbit for the potential $U(r) = -\frac{\alpha}{r}$

In a circular orbit, the particle only has tangential velocity and the quantization condition

$$\text{reads } \oint p dx = m v \cdot 2 \pi r = 2 \pi n \hbar$$

so

$$m v r = M = n \hbar$$

The energy of the particle is

$$E = \frac{n^2 \hbar^2}{2 m r^2} - \frac{\alpha}{r}$$

Equilibrium requires that the energy as a function of r be minimum. Thus

$$\frac{n^2 \hbar^2}{m r^3} = \frac{\alpha}{r^2} \quad \text{or } r = \frac{n^2 \hbar^2}{m \alpha}.$$

Hence

$$E_n = -\frac{m \alpha^2}{2 n^2 \hbar^2}.$$

6.46 The total energy of the H-atom in an arbitrary frame is

$$E = \frac{1}{2} m \vec{V}_1^2 + \frac{1}{2} M \vec{V}_2^2 - \frac{e^2}{(4 \pi \epsilon_0) |r_1 - r_2|}$$

Here $\vec{V}_1 = \dot{\vec{r}}_1$, $\vec{V}_2 = \dot{\vec{r}}_2$, \vec{r} , & \vec{r}_2 are the coordinates of the electron and protons.

We define

$$\vec{R} = \frac{m \vec{r}_1 + M \vec{r}_2}{M + m}$$

$$\vec{r} = \vec{r}_1 - \vec{r}_2$$

Then

$$\vec{V} = \frac{m \vec{V}_1 + M \vec{V}_2}{m + M}$$

$$\vec{v} = \vec{V}_1 - \vec{V}_2$$

or

$$\vec{V}_1 = \vec{V} + \frac{M}{m + M} \vec{v}$$

$$\vec{V}_2 = \vec{V} - \frac{m}{m + M} \vec{v}$$

and we get

$$E = \frac{1}{2} (m + M) \vec{V}^2 + \frac{1}{2} \frac{m M}{m + M} v^2 - \frac{e^2}{4 \pi \epsilon_0 r}$$

In the frame $\vec{V} = 0$, this reduces to the energy of a particle of mass

$$\mu = \frac{m M}{m + M}$$

μ is called the reduced mass.

Then

$$E_b = \frac{\mu e^4}{2 \hbar^2} \quad \text{and} \quad R = \frac{\mu e^4}{2 \hbar^3}$$

Since

$$\mu = \frac{m}{1 + \frac{m}{M}} \approx m \left(1 - \frac{m}{M} \right)$$

these values differ by $\frac{m}{M}$ ($\approx 0.54\%$) from the values obtained without considering nuclear motion. ($M = 1837 m$)

6.47 The difference between the binding energies is

$$\begin{aligned} \Delta E_b &= E_b(D) - E_b(H) \\ &= \Delta \frac{m}{1 + \frac{m}{M}} \frac{e^4}{2\hbar^2} + \frac{m}{1 + \frac{m}{2M}} \frac{e^4}{2\hbar^2} \\ &= \frac{m e^4}{2\hbar^2} \left(\frac{m}{2M} \right) \end{aligned}$$

Substitution gives $\Delta E_b = 3.7 \text{ meV}$.

For the first line of the Lyman series

$$\therefore \frac{2\pi\hbar c}{\lambda} = \hbar R \left(\frac{1}{1} - \frac{1}{4} \right) = \frac{3}{4} \hbar R$$

or

$$\lambda = \frac{8\pi c}{3R} = \frac{8\pi\hbar c}{3E_b}$$

Hence

$$\begin{aligned} \lambda_H - \lambda_D &= \frac{8\pi\hbar c}{3} \left(\frac{1}{E_b(H)} - \frac{1}{E_b(D)} \right) \\ &= \frac{8\pi\hbar c}{3} \cdot \left(\frac{m e^4}{2\hbar^2} \right)^{-1} \left(1 + \frac{m}{M} - 1 - \frac{m}{2M} \right) \\ &= \frac{8\pi\hbar c}{3} \cdot \frac{m}{\left(\frac{m e^4}{2\hbar^2} \right)} \cdot \frac{m}{2M} \\ &= \frac{m}{2M} \times \lambda_1 \end{aligned}$$

(where λ_1 is the wavelength of the first line of Lyman series without considering nuclear motion).

Substitution gives (see 6.21 for λ_1) using $\lambda_1 = 121 \text{ nm}$

$$\Delta \lambda = 33 \text{ pm}$$

- 6.48 (a) In the mesonic system, the reduced mass of the system is related to the masses of the meson (m_μ) and proton (m_p) by

$$\mu = \frac{m_\mu m_p}{m_\mu + m_p} = 186.04 m_e$$

Then,

$$\begin{aligned} \text{separation between the particles in the ground state} &= \frac{\hbar^2}{\mu e^2} \\ &= \frac{1}{186} \frac{\hbar^2}{m e^2} \\ &= 0.284 \text{ pm} \end{aligned}$$

$$\begin{aligned} E_b (\text{meson}) &= \frac{\mu e^4}{2\hbar^2} = 186 \times 13.65 \text{ eV} \\ &= 2.54 \text{ keV} \end{aligned}$$

$$\lambda_1 = \frac{8 \pi \hbar c}{3 E_b (\text{meson})} = \frac{\lambda_1 (\text{Hydrogen})}{186} = 0.65 \text{ nm}$$

(on using $\lambda_1 (\text{Hydrogen}) = 121 \text{ nm}$).

- (b) In the positronium

$$\mu = \frac{m_e^2}{2 m_e} = \frac{m_e}{2}$$

Thus separation between the particles is the ground state

$$= 2 \frac{\hbar^2}{m_e e^2} = 105.8 \text{ pm}$$

$$E_b (\text{positronium}) = \frac{m_e}{2} \cdot \frac{e^4}{2\hbar^2} = \frac{1}{2} E_b (H) = 6.8 \text{ eV}$$

$$\lambda_1 (\text{positronium}) = 2 \lambda_1 (\text{Hydrogen}) = 0.243 \text{ nm}$$

6.2 WAVE PROPERTIES OF PARTICLES. SCHRODINGER EQUATION

6.49 The kinetic energy is nonrelativistic in all three cases. Now

$$\lambda = \frac{2\pi\hbar}{p} = \frac{2\pi\hbar}{\sqrt{2mT}}$$

using

$$T = 1.602 \times 10^{-17} \text{ Joules, we get}$$

$$\lambda_e = 122.6 \text{ pm}$$

$$\lambda_p = 2.86 \text{ pm}$$

$$\lambda_U = \frac{\lambda_p}{\sqrt{238}} = 0.185 \text{ pm}.$$

(where we have used a mass number of 238 for the U nucleus).

6.50 From $\lambda = \frac{2\pi\hbar}{p} = \frac{2\pi\hbar}{\sqrt{2mT}}$

we find

$$T = \frac{4\pi^2\hbar^2}{2m\lambda^2} = \frac{2\pi^2\hbar^2}{m\lambda^2}$$

Thus

$$T_2 - T_1 = \frac{2\pi^2\hbar^2}{m} \left(\frac{1}{\lambda_2^2} - \frac{1}{\lambda_1^2} \right)$$

Substitution gives $\Delta T = 451 \text{ eV} = 0.451 \text{ keV}$.

6.51 We shall use $M_0 \approx 2M_n$. The CM is moving with velocity

$$V = \frac{\sqrt{2M_n T}}{3M_n} = \sqrt{\frac{2T}{9M_n}}$$

with respect to the Lab frame. In the CM frame the velocity of neutron is

$$v'_n = v_n - V = \sqrt{\frac{2T}{M_n}} - \sqrt{\frac{2T}{9M_n}} = \sqrt{\frac{2T}{M_n}} \cdot \frac{2}{3}$$

and

$$\lambda'_n = \frac{2\pi\hbar}{M_n v'_n} = \frac{3\pi\hbar}{\sqrt{2M_n T}}$$

Substitution gives $\lambda'_n = 8.6 \text{ pm}$

Since the momenta are equal in the CM frame the de Broglie wavelengths will also be equal.

If we do not assume $M_d \approx 2M_n$ we shall get

$$\lambda'_n = \frac{2\pi\hbar(1 + M_n/M_d)}{\sqrt{2M_n T}}$$

6.52 If \vec{p}_1, \vec{p}_2 are the momenta of the two particles then their momenta in the CM frame will be $\pm (\vec{p}_1 - \vec{p}_2)/2$ as the particles are identical.

Hence their de Broglie wavelength will be

$$\begin{aligned}\tilde{\lambda} &= \frac{2\pi\hbar}{\frac{1}{2}|\vec{p}_1 - \vec{p}_2|} = \frac{4\pi\hbar}{\sqrt{p_1^2 + p_2^2}} \quad (\text{because } \vec{p}_1 \perp \vec{p}_2) \\ &= \frac{2}{\sqrt{\frac{1}{\lambda_1^2} + \frac{1}{\lambda_2^2}}} = \frac{2\lambda_1\lambda_2}{\sqrt{\lambda_1^2 + \lambda_2^2}}\end{aligned}$$

6.53 In thermodynamic equilibrium, Maxwell's velocity distribution law holds :

$$dN(v) = \Phi(v) dv = A v^2 e^{-mv^2/2kT} dv$$

$\Phi(v)$ is maximum when

$$\Phi'(v) = \Phi(v) \left[\frac{2}{v} - \frac{mv}{kT} \right] = 0.$$

This defines the most probable velocity.

$$v_{pr} = \sqrt{\frac{2kT}{m}}.$$

The de Broglie wavelength of H molecules with the most probable velocity is

$$\lambda = \frac{2\pi\hbar}{m v_{pr}} = \frac{2\pi\hbar}{\sqrt{2mkT}}$$

Substituting the appropriate value especially

$$m = m_{H_2} = 2m_H, \quad T = 300 \text{ K}, \text{ we get}$$

$$\lambda = 126 \text{ pm}$$

6.54 To find the most probable de Broglie wavelength of a gas in thermodynamic equilibrium we determine the distribution λ corresponding to Maxwellian velocity distribution.

It is given by

$$\psi(\lambda) d\lambda = -\Phi(v) dv$$

(where - sign takes account of the fact that λ decreases as v increases). Now

$$\lambda = \frac{2\pi\hbar}{mv} \quad \text{or} \quad v = \frac{2\pi\hbar}{m\lambda}$$

$$dv = -\frac{2\pi\hbar}{m\lambda^2} d\lambda$$

Thus

$$\Psi(\lambda) = +A v^2 e^{-mv^2/2kT} \left(-\frac{dv}{d\lambda} \right)$$

$$\begin{aligned}
 &= A \left(\frac{2\pi\hbar}{m\lambda} \right)^2 \left(\frac{2\pi\hbar}{m\lambda^2} \right) e^{-\frac{m}{2kT} \cdot \left(\frac{2\pi\hbar}{m\lambda} \right)^2} \\
 &= \text{Const} \cdot \lambda^{-4} e^{-a/\lambda^2}
 \end{aligned}$$

where

$$a = \frac{2\pi^2\hbar^2}{m k T}$$

This is maximum when

$$\psi'(\lambda) = 0 = \psi(\lambda) \left[\frac{-4}{\lambda} + \frac{2a}{\lambda^3} \right]$$

or

$$\lambda_{pr} = \sqrt{a/2} = \pi\hbar / \sqrt{m k T}$$

Using the result of the previous problem it is

$$\lambda_{pr} = \frac{126}{\sqrt{2}} \text{ pm} = 89.1 \text{ pm}.$$

6.55 For a relativistic particle

$$T + m c^2 = \text{total energy} = \sqrt{c^2 p^2 + m^2 c^4}$$

Squaring

$$\sqrt{T(T + 2m c^2)} = c p$$

Hence

$$\begin{aligned}
 \lambda &= \frac{2\pi\hbar c}{\sqrt{T(T + 2m c^2)}} \\
 &= \frac{2\pi\hbar}{\sqrt{2mT \left(1 + \frac{T}{2m c^2} \right)}}
 \end{aligned}$$

If we use nonrelativistic formula,

$$\lambda_{NR} = \frac{2\pi\hbar}{\sqrt{2mT}}$$

so

$$\frac{\Delta\lambda}{\lambda} = \frac{\lambda_{NR} - \lambda}{\lambda_{NR}} = \frac{T}{4m c^2}$$

$$\left(\text{If } T/2m c^2 \ll 1, \text{ we can write } \left(1 + \frac{T}{2m c^2} \right)^{-1/2} = 1 - \frac{T}{4m c^2} \right)$$

Thus $T \leq \frac{4m c^2 \Delta\lambda}{\lambda}$ if the error is less than $\Delta\lambda$

For electron the error is not more than 1 % if

$$T \leq 4 \times 0.511 \times 0.01 \text{ MeV} \\ \leq 20.4 \text{ keV}$$

For a proton, the error is not more than 1 % if

$$T \leq 4 \times 938 \times 0.01 \text{ MeV}$$

i.e.

$$T \leq 37.5 \text{ MeV.}$$

6.56 The de Broglie wavelength is

$$\lambda_{dB} = \frac{\frac{2\pi\hbar}{m_0 v}}{\sqrt{1 - v^2/c^2}} = \frac{2\pi\hbar}{m_0 v} \sqrt{1 - v^2/c^2}$$

and the Compton wavelength is

$$\lambda_c = \frac{2\pi\hbar}{m_0 c}$$

The two are equal if $\beta = \sqrt{1 - \beta^2}$, where $\beta = \frac{v}{c}$

or

$$\beta = \frac{1}{\sqrt{2}}$$

The corresponding kinetic energy is

$$T = \frac{m_0 c^2}{\sqrt{1 - \beta^2}} - m_0 c^2 = (\sqrt{2} - 1) m_0 c^2$$

Here m_0 is the rest mass of the particle (here an electron).

6.57 For relativistic electrons, the formula for the short wavelength limit of X-rays will be

$$\frac{2\pi\hbar c}{\lambda_{sh}} = m_0 c^2 \left(\frac{1}{\sqrt{1 - \beta^2}} - 1 \right) = c \sqrt{p^2 + m^2 c^2} - m c^2$$

or

$$\left(\frac{2\pi\hbar}{\lambda_{sh}} + m c \right)^2 = p^2 + m^2 c^2$$

or

$$\left(\frac{2\pi\hbar}{\lambda_{sh}} \right) \left(\frac{2\pi\hbar}{\lambda_{sh}} + 2 m c \right) = p^2$$

or

$$p = \frac{2\pi\hbar}{\lambda_{sh}} \sqrt{1 + \frac{m c \lambda_{sh}}{\pi\hbar}}$$

Hence

$$\lambda_{dB} = \lambda_{sh} / \sqrt{1 + \frac{m c \lambda_{sh}}{\pi\hbar}} = 3.29 \text{ pm}$$

6.58 The first minimum in a Fraunhofer diffraction is given by (b is the width of the slit)
 $b \sin \theta = \lambda$

Here
$$\sin \theta = \frac{\Delta x/2}{\sqrt{l^2 + \left(\frac{\Delta x}{2}\right)^2}} = \frac{\Delta x}{2l}$$

Thus
$$\lambda = \frac{b \Delta x}{2l} = \frac{2 \pi \hbar}{m v}$$

so
$$v = \frac{4 \pi \hbar l}{m b \Delta x} = 2.02 \times 10^6 \text{ m/s}$$

6.59 From the Young slit formula

$$\Delta x = \frac{l \lambda}{d} = \frac{l}{d} \cdot \frac{2 \pi \hbar}{\sqrt{2 m e V}}$$

Substitution gives

$$\Delta x = 4.90 \mu \text{ m} .$$

6.60 From Bragg's law, for the first case

$$2 d \sin \theta = n_0 \lambda = n_0 \frac{2 \pi \hbar}{\sqrt{2 m e V_0}}$$

where n_0 is an unknown integer. For the next higher voltage

$$2 d \sin \theta = (n_0 + 1) \frac{2 \pi \hbar}{\sqrt{2 m e \eta V_0}}$$

Thus
$$n_0 = \frac{n_0 + 1}{\sqrt{\eta}}$$

or
$$n_0 \left(1 - \frac{1}{\sqrt{\eta}}\right) = \frac{1}{\sqrt{\eta}} \quad \text{or} \quad n_0 = \frac{1}{\sqrt{\eta} - 1}$$

Going back we get

$$V_0 = \frac{\pi^2 \hbar^2}{2 m e d^2 \sin^2 \theta} \frac{1}{(\sqrt{\eta} - 1)^2} = 0.150 \text{ keV}$$

Note :- In the Bragg's formula, θ is the glancing angle and not the angle of incidence. We have obtained correct result by taking θ to be the glancing angle. If θ is the angle of incidence, then the glancing angle will be $90 - \theta$. Then the final answer will be smaller by a factor

$$\tan^2 \theta = \frac{1}{3} .$$

6.61 Path difference is

$$d + d \cos \theta = 2d \cos^2 \frac{\theta}{2}$$

Thus for reflection maximum of the k^{th} order

$$2d \cos^2 \frac{\theta}{2} = k\lambda = k \frac{2\pi\hbar}{\sqrt{2mT}}$$

Hence
$$d = \frac{k\pi\hbar}{\sqrt{2mT}} \sec^2 \frac{\theta}{2}$$

Substitution with $k = 4$ gives

$$d = 0.232 \text{ nm}$$

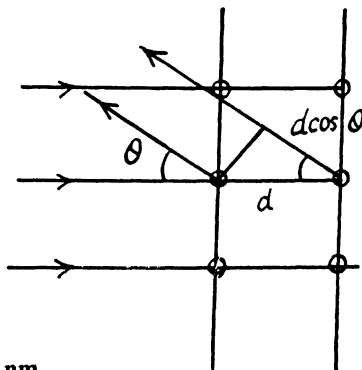

6.62 See the analogous problem with X-rays (5.156)

The glancing angle is obtained from

$$\tan 2\theta = \frac{D}{2l}$$

where D = diameter of the ring, l = distance from the foil to the screen.

Then for the third order Bragg reflection

$$2d \sin \theta = k\lambda = k \frac{2\pi\hbar}{\sqrt{2mT}}, (k = 3)$$

Thus
$$d = \frac{\pi\hbar k}{\sqrt{2mT} \sin \theta} = 0.232 \text{ nm}$$

6.63 Inside the metal, there is a negative potential energy of $-eV_i$. (This potential energy prevents electrons from leaking out and can be measured in photoelectric effect etc.) An electron whose K.E. is eV outside the metal will find its K.E. increased to $e(V + V_i)$ in the metal. Then

(a) de Broglie wavelength in the metal

$$= \lambda_m = \frac{2\pi\hbar}{\sqrt{2me(V + V_i)}}$$

Also de Broglie wavelength in vacuum

$$= \lambda_0 = \frac{2\pi\hbar}{\sqrt{2mVe}}$$

Hence refractive index
$$n = \frac{\lambda_0}{\lambda_m} = \sqrt{1 + \frac{V_i}{V}}$$

Substituting we get

$$n = \sqrt{1 + \frac{1}{10}} \approx 1.05$$

$$(b) \quad n - 1 = \sqrt{1 + \frac{V_i}{V}} - 1 \leq \eta$$

$$\text{then} \quad 1 + \frac{V_i}{V} \leq (1 + \eta)^2$$

$$\text{or} \quad V_i \leq \eta(2 + \eta)V$$

$$\text{or} \quad \frac{V}{V_i} \geq \frac{1}{\eta(2 + \eta)}$$

$$\text{For} \quad \eta = 1\% = 0.01$$

$$\text{we get} \quad \frac{V}{V_i} \geq 50$$

6.64 The energy inside the well is all kinetic if energy is measured from the value inside.
We require

$$l = n\lambda/2 = n \frac{\pi\hbar}{\sqrt{2mE}}$$

$$\text{or} \quad E_n = \frac{n^2 \pi^2 \hbar^2}{2ml^2}, \quad n = 1, 2, \dots$$

6.65 The Bohr condition

$$\oint p dx = \oint \frac{2\pi\hbar}{\lambda} dx = 2\pi n\hbar$$

For the case when λ is constant (for example in circular orbits) this means

$$2\pi r = n\lambda$$

Here r is the radius of the circular orbit.

6.66 From the uncertainty principle (Eqn. (6.2b))

$$\Delta x \Delta p_x \gtrsim \hbar$$

$$\text{Thus} \quad \Delta p_x = m \Delta v_x \gtrsim \frac{\hbar}{\Delta x}$$

$$\text{or} \quad \Delta v_x \gtrsim \frac{\hbar}{m \Delta x}$$

For an electron this means an uncertainty in velocity of 116 m/s if $\Delta x = 10^{-6} \text{ m} = 1 \mu\text{m}$

For a proton

$$\Delta v_x = 6.3 \text{ cm/s}$$

For a ball

$$\Delta v_x = 1 \times 10^{-20} \text{ cm/s}$$

6.67 As in the previous problem

$$\Delta v \gtrsim \frac{\hbar}{m l} = 1.16 \times 10^6 \text{ m/s}$$

The actual velocity v_1 has been calculated in problem 6.21. It is

$$v_1 = 2.21 \times 10^6 \text{ m/s}$$

Thus $\Delta v \sim v_1$ (They are of the same order of magnitude)

6.68 If $\Delta x = \lambda/2\pi = \frac{2\pi\hbar}{p} \cdot \frac{1}{2\pi} = \frac{\hbar}{p} = \frac{\hbar}{m v}$

Thus
$$\Delta v \gtrsim \frac{\hbar}{m \Delta x} = v$$

Thus Δv is of the same order as v .

6.69 Initial uncertainty $\Delta v \gtrsim \frac{\hbar}{m l}$. With this uncertainty the wave train will spread out to a distance ηl long in time

$$t_0 \approx \eta l / \frac{\hbar}{m l} \approx \frac{\eta m l^2}{\hbar} \text{ sec.} = 8.6 \times 10^{16} \text{ sec.} \sim 10^{-15} \text{ sec.}$$

6.70 Clearly $\Delta x \leq l$ so $\Delta p_x \geq \frac{\hbar}{l}$

Now $p_x \geq \Delta p_x$ and so

$$T = \frac{p_x^2}{2m} \geq \frac{\hbar^2}{2m l^2}$$

Thus
$$T_{\min} = \frac{\hbar^2}{2m l^2} \approx 0.95 \text{ eV.}$$

6.71 The momentum the electron is $\Delta p_x = \sqrt{2mT}$

Uncertainty in its momentum is

$$\Delta p_x \geq \hbar / \Delta x = \hbar / l$$

Hence relative uncertainty

$$\frac{\Delta p_x}{p_x} = \frac{\hbar}{l \sqrt{2mT}} = \sqrt{\frac{\hbar^2}{2m l^2}} / T = \frac{\Delta v}{v}$$

Substitution gives

$$\frac{\Delta v}{v} = \frac{\Delta p}{p} = 9.75 \times 10^{-5} \approx 10^{-4}$$

6.72 By uncertainty principle, the uncertainty in momentum

$$\Delta p \gtrsim \frac{\hbar}{l}$$

For the ground state, we expect $\Delta p \sim p$ so

$$E \sim \frac{\hbar^2}{2ml^2}$$

The force exerted on the wall can be obtained most simply from

$$F = -\frac{\partial U}{\partial l} = \frac{\hbar^2}{ml^3}.$$

6.73 We write

$$p \sim \Delta p \sim \frac{\hbar}{\Delta x} \sim \frac{\hbar}{x}$$

i.e. all four quantities are of the same order of magnitude. Then

$$E \approx \frac{\hbar^2}{2mx^2} + \frac{1}{2}kx^2 = \frac{1}{2m} \left(\frac{\hbar}{x} - \sqrt{mk}x \right)^2 + \hbar \sqrt{\frac{k}{m}}$$

Thus we get an equilibrium situation ($E = \text{minimum}$) when

$$x = x_0 = \sqrt{\frac{\hbar}{\sqrt{mk}}}$$

and then

$$E = E_0 \sim \hbar \sqrt{\frac{k}{m}} = \hbar \omega$$

Quantum mechanics gives

$$E_0 = \hbar \omega / 2$$

6.74 Hence we write

$$r \sim \Delta r, p \sim \Delta p \sim \hbar / \Delta r$$

Then

$$\begin{aligned} E &= \frac{\hbar^2}{2mr^2} - \frac{e^2}{r} \\ &= \frac{1}{2m} \left(\frac{\hbar}{r} - \frac{me^2}{\hbar} \right)^2 - \frac{me^4}{2\hbar^2} \end{aligned}$$

Hence $r_{\text{eff}} = \frac{\hbar^2}{me^2} = 53 \text{ pm}$ for the equilibrium state.

and then

$$E = -\frac{me^4}{2\hbar^2} = -13.6 \text{ eV}.$$

6.75 Suppose the width of the slit (its extension along the y -axis) is δ . Then each electron has an uncertainty $\Delta y \sim \delta$. This translates to an uncertainty $\Delta p_y \sim \hbar/\delta$. We must therefore have $p_y \gtrsim \hbar/\delta$.

For the image, brodening has two sources.

We write

$$\Delta(\delta) = \delta + \Delta'(\delta)$$

where Δ' is the width caused by the spreading of electrons due to their transverse momentum.

We have

$$\Delta' = v_y \frac{l}{v_x} = p_y \frac{l}{p} = \frac{l\hbar}{mv\delta}$$

Thus

$$\Delta(\delta) = \delta + \frac{l\hbar}{mv\delta}$$

For large δ , $\Delta(\delta) \sim \delta$ and quantum effect is unimportant. For small δ , quantum effects are large. But $\Delta(\delta)$ is minimum when

$$\delta = \sqrt{\frac{l\hbar}{mv}}$$

as we see by completing the square. Substitution gives

$$\delta = 1.025 \times 10^{-5} \text{ m} \approx 0.01 \text{ mm}$$

6.76 The Schrodinger equation in one dimension for a free particle is

$$i\hbar \frac{\partial \psi}{\partial t} = -\frac{\hbar^2}{2m} \frac{\partial^2 \psi}{\partial x^2}$$

we write $\psi(x, t) = \varphi(x) \chi(t)$. Then

$$\frac{i\hbar}{\chi} \frac{d\chi}{dt} = -\frac{\hbar^2}{2m} \frac{1}{\varphi} \frac{d^2\varphi}{dx^2} = E, \text{ say}$$

Then

$$\chi(t) \sim \exp\left(-\frac{iEt}{\hbar}\right)$$

$$\varphi(x) \sim \exp\left(i\frac{\sqrt{2mE}}{\hbar}x\right)$$

E must be real and positive if $\varphi(x)$ is to be bounded everywhere. Then

$$\psi(x, t) = \text{Const} \exp\left(\frac{i}{\hbar}(\sqrt{2mE}x - Et)\right)$$

This particular solution describes plane waves.

6.77 We look for the solution of Schrodinger eqn. with

$$-\frac{\hbar^2}{2m} \frac{d^2 \psi}{dx^2} = E \psi, \quad 0 \leq x \leq l \quad (1)$$

The boundary condition of impenetrable walls means

$$\psi(x) = 0 \text{ for } x = 0 \text{ and } x = l \\ (\text{as } \psi(x) = 0 \text{ for } x < 0 \text{ and } x > l,)$$

The solution of (1) is

$$\psi(x) = A \sin \frac{\sqrt{2mE}}{\hbar} x + B \cos \frac{\sqrt{2mE}}{\hbar} x$$

Then

$$\psi(0) = 0 \Rightarrow B = 0$$

$$\psi(l) = 0 \Rightarrow A \sin \frac{\sqrt{2mE}}{\hbar} l = 0$$

$A \neq 0$ so

$$\frac{\sqrt{2mE}}{\hbar} l = n\pi$$

Hence

$$E_n = \frac{n^2 \pi^2 \hbar^2}{2ml^2}, \quad n = 1, 2, 3, \dots$$

Thus the ground state wave function is

$$\psi(x) = A \sin \frac{\pi x}{l}.$$

We evaluate A by normalization

$$1 = A^2 \int_0^l \sin^2 \frac{\pi x}{l} dx = A^2 \frac{l}{\pi} \int_0^\pi \sin^2 \theta d\theta = A^2 \frac{l}{\pi} \cdot \frac{\pi}{2}$$

Thus

$$A = \sqrt{\frac{2}{l}}$$

Finally, the probability P for the particle to lie in $\frac{l}{2} \leq x \leq \frac{2l}{3}$ is

$$P = P\left(\frac{l}{3} \leq x \leq \frac{2l}{3}\right) = \frac{2}{l} \int_{\frac{l}{3}}^{\frac{2l}{3}} \sin^2 \frac{\pi x}{l} dx \\ = \frac{2}{\pi} \int_{\pi/3}^{2\pi/3} \sin^2 \theta d\theta = \frac{1}{\pi} \int_{\pi/3}^{2\pi/3} (1 - \cos 2\theta) d\theta$$

$$\begin{aligned}
 &= \frac{1}{\pi} \left(\theta - \frac{1}{2} \sin 2\theta \right)_{\pi/3}^{2\pi/3} = \frac{1}{\pi} \left(\frac{2\pi}{3} - \frac{\pi}{3} - \frac{1}{2} \sin \frac{4\pi}{3} + \frac{1}{2} \sin \frac{2\pi}{3} \right) \\
 &= \frac{1}{\pi} \left(\frac{\pi}{3} + \frac{1}{2} \frac{\sqrt{3}}{2} + \frac{1}{2} \frac{\sqrt{3}}{2} \right) = \frac{1}{3} + \frac{\sqrt{3}}{2\pi} = 0.609
 \end{aligned}$$

6.78 Here $-\frac{l}{2} \leq x \leq \frac{l}{2}$. Again we have

$$\psi(x) = B \cos \frac{\sqrt{2mE}x}{\hbar} + A \sin \frac{\sqrt{2mE}x}{\hbar}$$

Then the boundary condition $\psi\left(\pm \frac{l}{2}\right) = 0$

gives
$$B \cos \frac{\sqrt{2mE}l}{2\hbar} \pm A \sin \frac{\sqrt{2mE}l}{2\hbar} = 0$$

There are two cases.

(1) $A = 0$, $\frac{\sqrt{2mE}l}{2\hbar} = n\pi + \frac{\pi}{2}$

gives even solution. Here

$$\sqrt{2mE} = (2n+1) \frac{\pi\hbar}{l}$$

and

$$E_n = (2n+1)^2 \frac{\pi^2 \hbar^2}{2ml^2}$$

$$\psi_n^e(x) = \sqrt{\frac{2}{l}} \cos(2n+1) \frac{\pi x}{l}$$

$$n = 0, 1, 2, 3, \dots$$

This solution is even under $x \rightarrow -x$.

(2) $B = 0$,

$$\frac{\sqrt{2mE}l}{2\hbar} = n\pi, \quad n = 1, 2, \dots$$

$$E_n = (2n\pi)^2 \frac{\hbar^2}{2ml^2}$$

$$\psi_n^o = \sqrt{\frac{2}{l}} \sin \frac{2n\pi x}{l}, \quad n = 1, 2, \dots \text{ This solution is odd.}$$

6.79 The wave function is given in 6.77. We see that

$$\int_0^l \psi_n(x) \psi_{n'}(x) dx = \frac{2}{l} \int_0^l \sin \frac{n\pi x}{l} \sin \frac{n'\pi x}{l} dx$$

$$\begin{aligned}
 &= \frac{1}{l} \int_0^l \left[\cos(n-n') \frac{\pi x}{l} - \cos(n+n') \frac{\pi x}{l} \right] dx \\
 &= \frac{1}{l} \left[\frac{\sin(n-n') \pi x/l}{(n-n') \frac{\pi}{l}} - \frac{\sin(n+n') \frac{\pi x}{l}}{(n+n') \frac{\pi}{l}} \right]_0^l e.
 \end{aligned}$$

If $n \neq n'$, this is zero as n and n' are integers.

6.80 We have found that

$$E_n = \frac{n^2 \pi^2 \hbar^2}{2 m l^2}$$

Let $N(E)$ = number of states upto E . This number is n . The number of states upto $E + dE$ is $N(E + dE) = N(E) + dN(E)$. Then $dN(E) = 1$ and

$$\frac{dN(E)}{dE} = \frac{1}{\Delta E}$$

where ΔE = difference in energies between the n^{th} & $(n+1)^{\text{th}}$ level

$$\begin{aligned}
 &= \frac{(n+1)^2 - n^2}{2 m l^2} \pi^2 \hbar^2 = \frac{2n+1}{2 m l^2} \pi^2 \hbar^2 \\
 &= \frac{\pi^2 \hbar^2}{2 m l^2} 2n, \quad (\text{neglecting } 1 \ll n) \\
 &= \frac{\pi^2 \hbar^2}{2 m l^2} \times \sqrt{\frac{2 m l^2}{\pi^2 \hbar^2}} \sqrt{E} \times 2 \\
 &= \frac{\pi \hbar}{l} \sqrt{\frac{2}{m}} \sqrt{E}
 \end{aligned}$$

Thus
$$\frac{dN(E)}{dE} = \frac{l}{\pi \hbar} \sqrt{\frac{m}{2E}}$$

For the given case this gives $\frac{dN(E)}{dE} = 0.816 \times 10^7$ levels per eV

6.81 (a) Here the schrodinger equation is

$$-\frac{\hbar^2}{2m} \left(\frac{\partial^2}{\partial x^2} + \frac{\partial^2}{\partial y^2} \right) \psi = E \psi$$

we take the origin at one of the corners of the rectangle where the particle can lie. Then the wave function must vanish for

$$x = 0 \quad \text{or} \quad x = l_1$$

$$\text{or} \quad y = 0 \quad \text{or} \quad y = l_2.$$

we look for a solution in the form

$$\psi = A \sin k_1 x \sin k_2 y$$

cosines are not permitted by the boundary condition. Then

$$k_1 = \frac{n_1 \pi}{l_1}, \quad k_2 = n_2 \frac{\pi}{l_2}$$

and

$$E = \frac{k_1^2 + k_2^2}{2m} \hbar^2 = \frac{\pi^2 \hbar^2}{2m} \left(\frac{n_1^2}{l_1^2} + \frac{n_2^2}{l_2^2} \right)$$

Here n_1, n_2 are nonzero integers.

(b) If $l_1 = l_2 = l$ then

$$\frac{E}{\hbar^2/m l^2} = \frac{n_1^2 + n_2^2}{2} \pi^2$$

1st level :

$$n_1 = n_2 = 1 \rightarrow \pi^2 = 9.87$$

2nd level :

$$\left. \begin{array}{l} n_1 = 1, n_2 = 2 \\ \text{or } n_1 = 2, n_2 = 1 \end{array} \right\} \rightarrow \frac{5}{2} \pi^2 = 24.7$$

3rd level :

$$n_1 = 2, n_2 = 2 \rightarrow 4 \pi^2 = 39.5$$

4th level :

$$\left. \begin{array}{l} n_1 = 1, n_2 = 3 \\ n_1 = 3, n_2 = 1 \end{array} \right\} \rightarrow 5 \pi^2 = 49.3$$

6.82 The wave function for the ground state is

$$\psi_{11}(x, y) = A \sin \frac{\pi x}{a} \sin \frac{\pi y}{b}$$

we find A by normalization

$$1 = A^2 \int_0^a dx \int_0^b dy \sin^2 \frac{\pi x}{a} \sin^2 \frac{\pi y}{b} = A^2 \frac{a b}{4}$$

Thus

$$A = \frac{2}{\sqrt{a b}}.$$

Then the requisite probability is

$$\begin{aligned} P &= \int_0^{a/3} dx \int_0^b dy \frac{4}{a b} \sin^2 \frac{\pi x}{a} \sin^2 \frac{\pi y}{b} \\ &= \frac{2}{a} \int_0^{a/3} dx \sin^2 \frac{\pi x}{a} \quad \text{on doing the } y \text{ integral} \end{aligned}$$

$$\begin{aligned}
 &= \frac{1}{a} \int_0^{a/3} d \left(1 - \cos \frac{2\pi x}{a} \right) = \frac{1}{a} \left(\frac{a}{3} - \frac{\sin \frac{2\pi}{3}}{2\pi/a} \right) \\
 &= \frac{1}{3} - \frac{\sqrt{3}}{4\pi} = 0.196 = 19.6\%.
 \end{aligned}$$

6.83 We proceed exactly as in (6.81). The wave function is chosen in the form

$$\psi(x, y, z) = A \sin k_1 x \sin k_2 y \sin k_3 z.$$

(The origin is at one corner of the box and the axes of coordinates are along the edges.) The boundary conditions are that $\psi = 0$ for

$$x = 0, x = a, y = 0, y = a, z = 0, z = a$$

This gives

$$k_1 = \frac{n_1 \pi}{a}, k_2 = \frac{n_2 \pi}{a}, k_3 = \frac{n_3 \pi}{a}$$

The energy eigenvalues are

$$E(n_1, n_2, n_3) = \frac{\pi^2 \hbar^2}{2ma^2} (n_1^2 + n_2^2 + n_3^2)$$

The first level is (1, 1, 1). The second has (1, 1, 2), (1, 2, 1) & (2, 1, 1). The third level is (1, 2, 2) or (2, 1, 2) or (2, 2, 1). Its energy is

$$\frac{9\pi^2 \hbar^2}{2ma^2}$$

The fourth energy level is (1, 1, 3) or (1, 3, 1) or (3, 1, 1)

Its energy is

$$E = \frac{11\pi^2 \hbar^2}{2ma^2}.$$

(b) Thus

$$\Delta = E_4 - E_3 = \frac{\hbar^2 \pi^2}{ma^2}.$$

(c) The fifth level is (2, 2, 2). The sixth level is (1, 2, 3), (1, 3, 2), (2, 1, 3), (2, 3, 1), (3, 1, 2), (3, 2, 1)

Its energy is

$$\frac{7\hbar^2 \pi^2}{ma^2}$$

and its degree of degeneracy is 6 (six).

6.84 We can for definiteness assume that the discontinuity occurs at the point $x = 0$. Now the Schrodinger equation is

$$-\frac{\hbar^2}{2m} \frac{d^2 \psi}{dx^2} + U(x) \psi(x) = E \psi(x)$$

We integrate this equation around $x = 0$ i.e., from $x = -\varepsilon_1$ to $x = +\varepsilon_2$ where $\varepsilon_1, \varepsilon_2$ are small positive numbers. Then

$$-\frac{\hbar^2}{2m} \int_{-\varepsilon_1}^{+\varepsilon_2} \frac{d^2 \psi}{dx^2} dx = \int_{-\varepsilon_1}^{+\varepsilon_2} (E - U(x)) \psi(x) dx$$

or

$$\left(\frac{d\psi}{dx} \right)_{+\varepsilon_2} - \left(\frac{d\psi}{dx} \right)_{-\varepsilon_1} = -\frac{2m}{\hbar^2} \int_{-\varepsilon_1}^{\varepsilon_2} (E - U(x)) dx \psi(x)$$

Since the potential and the energy E are finite and $\psi(x)$ is bounded by assumption, the integral on the right exists and $\rightarrow 0$ as $\varepsilon_1, \varepsilon_2 \rightarrow 0$

Thus

$$\left(\frac{d\psi}{dx} \right)_{+\varepsilon_2} = \left(\frac{d\psi}{dx} \right)_{-\varepsilon_1} \quad \text{as } \varepsilon_1, \varepsilon_2 \rightarrow 0$$

So $\left(\frac{d\psi}{dx} \right)$ is continuous at $x = 0$ (the point where $U(x)$ has a finite jump discontinuity.)

6.85

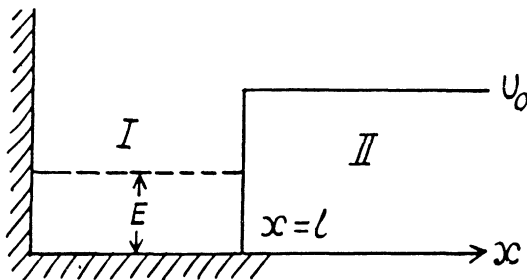

(a) Starting from the Schrodinger equation in the regions I & II

$$\frac{d^2 \psi}{dx^2} + \frac{2mE}{\hbar^2} \psi = 0 \quad x \text{ in } I \quad (1)$$

$$\frac{d^2 \psi}{dx^2} - \frac{2mE(U_0 - E)}{\hbar^2} \psi = 0 \quad x \text{ in } II \quad (2)$$

where $U_0 > E > 0$, we easily derive the solutions in I & II

$$\Psi_I(x) = A \sin kx + B \cos kx \quad (3)$$

$$\Psi_{II}(x) = C e^{\alpha x} + D e^{-\alpha x} \quad (4)$$

where
$$k^2 = \frac{2mE}{\hbar^2}, \quad \alpha^2 = \frac{2m(U_0 - E)}{\hbar^2}.$$

The boundary conditions are

$$\Psi(0) = 0 \quad (5)$$

and Ψ & $\left(\frac{d\Psi}{dx}\right)$ are continuous at $x = l$, and Ψ must vanish at $x = +\infty$.

Then
$$\Psi_I = A \sin kx$$

and
$$\Psi_{II} = D e^{-\alpha x}$$

so
$$A \sin kl = D e^{-\alpha l}$$

$$kA \cos kl = -\alpha D e^{-\alpha l}$$

From this we get

$$\tan kl = -\frac{k}{\alpha}$$

or
$$\begin{aligned} \sin kl &= \pm kl / \sqrt{k^2 l^2 + \alpha^2 l^2} \\ &= \pm kl / \sqrt{\frac{2mU_0 l^2}{\hbar^2}} \\ &= \pm kl \sqrt{\hbar^2 / 2mU_0 l^2} \end{aligned} \quad (6)$$

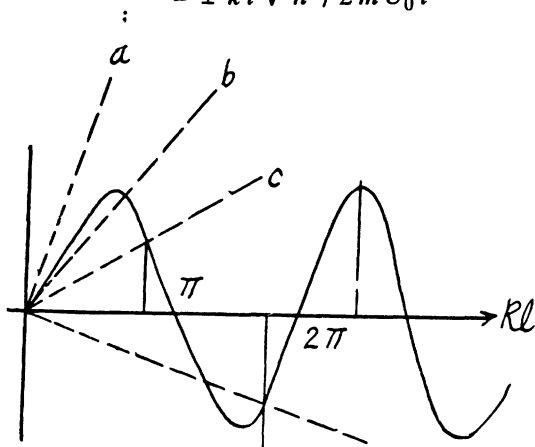

Plotting the left and right sides of this equation we can find the points at which the straight lines cross the sine curve. The roots of the equation corresponding to the eigen values of energy E_i and found from the inter section points $(kl)_i$, for which $\tan(kl)_i < 0$ (i.e. 2nd & 4th and other even quadrants). It is seen that bound states do not always exist. For the first bound state to appear (refer to the line (b) above)

$$(kl)_{1, \min} = \frac{\pi}{2}$$

(b) Substituting, we get $(l^2 U_0)_{1,\min} = \frac{\pi^2 \hbar^2}{8m}$

as the condition for the appearance of the first bound state. The second bound state will appear when kl is in the fourth quadrant. The magnitude of the slope of the straight line must then be less than

$$\frac{1}{3\pi/2}$$

Corresponding to $(kl)_{2,\min} = \frac{3\pi}{2} = (3)\frac{\pi}{2} = (2 \times 2 - 1)\frac{\pi}{2}$

For n bound states, it is easy to convince one self that the slope of the appropriate straight line (upper or lower) must be less than

$$(kl)_{n,\min} = (2n - 1)\frac{\pi}{2}$$

Then $(l^2 U_0)_{n,\min} = \frac{(2n - 1)^2 \pi^2 \hbar^2}{8m}$

Do not forget to note that for large n both + and - signs in the Eq. (6) contribute to solutions.

6.86 $U_0 l^2 = \left(\frac{3}{4}\pi\right)^2 \frac{\hbar^2}{m}$

and

$$E l^2 = \left(\frac{3}{4}\pi\right)^2 \frac{\hbar^2}{2m}$$

or

$$kl = \frac{3}{4}\pi$$

It is easy to check that the condition of the bound state is satisfied. Also

$$\alpha l = \sqrt{\frac{2m}{\hbar^2}(U_0 - E)} l^2 = \sqrt{\frac{m U_0}{\hbar^2}} l^2 = \frac{3}{4}\pi$$

Then from the previous problem

$$D = A e^{\alpha l} \sin kl = A \frac{e^{3\pi/4}}{\sqrt{2}}$$

By normalization

$$I = A^2 \left[\int_0^l \sin^2 kx dx + \int_l^\infty \frac{e^{3\pi/2}}{2} e^{-(3\pi/2)x/l} dx \right]$$

$$\begin{aligned}
&= A^2 \left[\frac{1}{2} \int_0^l (1 - \cos 2kx) dx + l \int_0^{\infty} \frac{1}{2} e^{-\frac{3\pi}{2}y} dy \right] \\
&= A^2 \left[\frac{1}{2} \left[-\frac{\sin 2kl}{2k} \right] + \frac{1}{2} \cdot \frac{l}{2} \right] = A^2 l \left[\frac{1}{2} \left[1 + \frac{3\pi}{2} \right] + \frac{1}{2} \cdot \frac{1}{2} \right] \\
&= A^2 l \left[\frac{1}{2} + \frac{2}{3\pi} \right] = A^2 \frac{l}{2} \left(1 + \frac{4}{3\pi} \right) \text{ or } A = \sqrt{\frac{2}{l}} \left(1 + \frac{4}{3\pi} \right)^{-1/2}
\end{aligned}$$

The probability of the particle to be located in the region $x > l$ is

$$\begin{aligned}
P &= \int_l^{\infty} \psi^2 dx = \frac{2}{l} \left(1 + \frac{4}{3\pi} \right)^{-1} \int_l^{\infty} \frac{e^{3\pi/2}}{2} e^{-\frac{3\pi x}{2l}} dx \\
&= \left(1 + \frac{4}{3\pi} \right)^{-1} \int_l^{\infty} e^{3\pi/2} e^{-(3\pi/2)y} dy = \frac{2}{3\pi} \times \frac{3\pi}{3\pi + 4} = 14.9\%.
\end{aligned}$$

6.87 The Schrodinger equation is

$$\nabla^2 \psi + \frac{2m}{\hbar^2} (E - U(r)) \psi = 0$$

when ψ depends on r only,
$$\nabla^2 \psi = \frac{1}{r^2} \frac{d}{dr} \left(r^2 \frac{d\psi}{dr} \right)$$

If we put
$$\psi = \frac{\chi(r)}{r}, \quad \frac{d\psi}{dr} = \frac{\chi'}{r} - \frac{\chi}{r^2}$$

and
$$\nabla^2 \psi = \frac{\chi''}{r}. \text{ Thus we get}$$

$$\frac{d^2 \chi}{dr^2} + \frac{2m}{\hbar^2} (E - U(r)) \chi = 0$$

The solution is

$$\chi = A \sin kr, \quad r < r_0$$

$$k^2 = \frac{2mE}{\hbar^2}$$

and

$$\chi = 0 \quad r > r_0$$

(For $r < r_0$ we have rejected a term $B \cos kr$ as it does not vanish at $r = 0$). Continuity of the wavefunction at $r = r_0$ requires

$$kr_0 = n\pi$$

Hence

$$E_n = \frac{n^2 \pi^2 \hbar^2}{2m r_0^2}.$$

6.88 (a) The normalized wave functions are obtained from the normalization

$$\begin{aligned} 1 &= \int |\psi|^2 dV = \int |\psi|^2 4\pi r^2 dr \\ &= \int_0^{r_0} A^2 4\pi \chi^2 dr = 4\pi A^2 \int_0^{r_0} \sin^2 \frac{n\pi r}{r_0} dr \\ &= 4\pi A^2 \frac{r_0}{n\pi} \int_0^{n\pi} \sin^2 x dx = 4\pi A^2 \frac{r_0}{n\pi} \cdot \frac{n\pi}{2} = r_0 \cdot 2\pi A^2 \end{aligned}$$

Hence
$$A = \frac{1}{\sqrt{2\pi r_0}} \quad \text{and} \quad \psi = \frac{1}{\sqrt{2\pi \cdot r_0}} \frac{\sin \frac{n\pi r}{r_0}}{r}$$

(b) The radial probability distribution function is

$$P_n(r) = 4\pi r^2 (\psi)^2 = \frac{2}{r_0} \sin^2 \frac{n\pi r}{r_0}$$

For the ground state $n = 1$

so
$$P_1(r) = \frac{2}{r_0} \sin^2 \frac{\pi r}{r_0}$$

By inspection this is maximum for $r = \frac{r_0}{2}$. Thus $r_{pr} = \frac{r_0}{2}$

The probability for the particle to be found in the region $r < r_{pr}$ is clearly 50 % as one can immediately see from a graph of $\sin^2 x$.

6.89 If we put $\psi = \frac{\chi(r)}{r}$

the equation for $\chi(r)$ has the form

$$\chi'' + \frac{2m}{\hbar^2} [E - U(r)] \chi(r) = 0$$

which can be written as $\chi'' + k^2 \chi = 0, 0 \leq r < r_0$

and $\chi'' - \alpha^2 \chi = 0 \quad r_0 < r < \infty$

where $k^2 = \frac{2mE}{\hbar^2}, \alpha^2 = \frac{2m(U_0 - E)}{\hbar^2}$.

The boundary condition is

$$\left. \begin{aligned} \chi(0) &= 0 \\ \text{and } \chi, \chi' &\text{ are continuous at } r = r_0 \end{aligned} \right\}$$

These are exactly same as in the one dimensional problem in problem (6.85)

We therefore omit further details

6.90 The Schrodinger equation is $\frac{d^2\Psi}{dx^2} + \frac{2m}{\hbar^2} (E - \frac{1}{2}kx^2)\Psi = 0$

We are given

$$\Psi = A e^{-\alpha x^2/2}$$

Then

$$\Psi' = -\alpha x A e^{-\alpha x^2/2}$$

$$\Psi'' = -\alpha A e^{-\alpha x^2/2} + \alpha^2 x^2 A e^{-\alpha x^2/2}$$

Substituting we find that following equation must hold

$$\left[(\alpha^2 x^2 - \alpha) + \frac{2m}{\hbar^2} (E - \frac{1}{2}kx^2) \right] \Psi = 0$$

since $\Psi \neq 0$, the bracket must vanish identically. This means that the coefficient of x^2 as well as the term independent of x must vanish. We get

$$\alpha^2 = \frac{mk}{\hbar^2} \quad \text{and} \quad \alpha = \frac{2mE}{\hbar^2}$$

Putting $k/m = \omega^2$, this leads to $\alpha = \frac{m\omega}{\hbar^2}$ and $E = \frac{\hbar^2}{2}$

6.91 The Schrödinger equation for the problem in Gaussian units

$$\nabla^2 \psi + \frac{2m}{\hbar^2} \left[E + \frac{e^2}{r} \right] \psi = 0$$

In MKS units we should read $(e^2/4\pi\epsilon_0)$ for e^2 .

we put $\psi = \frac{\chi(r)}{r}$. Then $\chi'' + \frac{2m}{\hbar^2} \left[E + \frac{e^2}{r} \right] \chi = 0$ (1)

We are given that $\chi = r\psi = Ar(1+ar)e^{-\alpha r}$

so $\chi' = A(1+2ar)e^{-\alpha r} - \alpha Ar(1+ar)e^{-\alpha r}$

$$\chi'' = \alpha^2 Ar(1+ar)e^{-\alpha r} - 2\alpha A(1+2ar)e^{-\alpha r} + 2aAe^{-\alpha r}$$

Substitution in (1) gives the condition

$$\alpha^2(r+ar^2) - 2\alpha(1+2ar) + 2a + \frac{2m}{\hbar^2}(Er + e^2) \times (1+ar) = 0$$

Equating the coefficients of r^2 , r , and constant term to zero we get

$$2a - 2\alpha + \frac{2me^2}{\hbar^2} = 0 \quad (2)$$

$$a\alpha^2 + \frac{2m}{\hbar^2}Ea = 0 \quad (3)$$

$$\alpha^2 - 4a\alpha + \frac{2m}{\hbar^2}(E + e^2a) = 0 \quad (4)$$

From (3) either $a = 0$, or $E = -\frac{\hbar^2\alpha^2}{2m}$

In the first case
$$\alpha = \frac{m e^2}{\hbar^2}, E = -\frac{\hbar^2}{2m} \alpha^2 = -\frac{m e^4}{2\hbar^2}$$

This state is the ground state.

In the second case
$$a = \alpha - \frac{m e^2}{\hbar^2}, \alpha = \frac{1}{2} \frac{m e^2}{\hbar^2}$$

$$E = -\frac{m e^4}{8\hbar^2} \quad \text{and} \quad a = -\frac{1}{2} \frac{m e^2}{\hbar^2}$$

This state is one with $n = 2$ (2s).

6.92 We first find A by normalization

$$1 = \int_0^{\infty} 4\pi A^2 e^{-2r/r_1} r^2 dr = \frac{\pi A^2}{2} r_1^3 \int_0^{\infty} e^{-x} x^2 dx = \pi A^2 r_1^3$$

since the integral has the value 2.

Thus
$$A^2 = \frac{1}{\pi r_1^3} \quad \text{or} \quad A = \frac{1}{\sqrt{r_1^3 \pi}}$$

(a) The most probable distance r_{pr} is that value of r for which

$$P(r) = 4\pi r^2 |\psi(r)|^2 = \frac{4}{r_1^3} r^2 e^{-2r/r_1}$$

is maximum. This requires

$$P'(r) = \frac{4}{r_1^3} \left[2r - \frac{2r^2}{r_1} \right] e^{-2r/r_1} = 0$$

or

$$r = r_1 = r_{pr}$$

(b) The coulomb force being given by $-e^2/r^2$, the mean value of its modulus is

$$\begin{aligned} \langle F \rangle &= \int_0^{\infty} 4\pi r^2 \frac{1}{\pi r_1^3} e^{-2r/r_1} \frac{e^2}{r^2} dr \\ &= \int_0^{\infty} \frac{4e^2}{r_1^3} e^{-2r/r_1} dr = \frac{2e^2}{r_1^2} \int_0^{\infty} e^{-x} dx = \frac{2e^2}{r_1^2} \end{aligned}$$

In MKS units we should read $(e^2/4\pi\epsilon_0)$ for e^2

(c)
$$\langle U \rangle = \int_0^{\infty} 4\pi r^2 \frac{1}{\pi r_1^3} e^{-2r/r_1} \frac{-e^2}{r} dr = -\frac{e^2}{r_1} \int_0^{\infty} x e^{-x} dx = -\frac{e^2}{r_1}$$

In MKS units we should read $(e^2/4\pi\epsilon_0)$ for e^2 .

6.93 We find A by normalization as above. We get

$$A = \frac{1}{\sqrt{\pi r_1^3}}$$

Then the electronic charge density is

$$\rho = -e |\psi|^2 = -e \frac{e^{-2r/r_1}}{\pi r_1^3} = \rho(\vec{r})$$

The potential $\psi(\vec{r})$ due to this charge density is

$$\varphi(\vec{r}) = \frac{1}{4\pi\epsilon_0} \int \frac{\rho(\vec{r}')}{|\vec{r}-\vec{r}'|} d^3 r'$$

$$\begin{aligned} \text{so at the origin } \varphi(0) &= \frac{1}{4\pi\epsilon_0} \int_0^\infty \frac{\rho(r')}{r'} 4\pi r'^2 dr' = \frac{-e}{4\pi\epsilon_0} \int_0^\infty \frac{4r'}{r_1^3} e^{-2r'/r_1} dr' \\ &= -\frac{e}{4\pi\epsilon_0 r_1} \int_0^\infty x e^{-x} dx = -\frac{e}{(4\pi\epsilon_0) r_1} \end{aligned}$$

6.94 (a) We start from the Schrodinger equation $\frac{d^2 \psi}{dx^2} + \frac{2m}{\hbar^2} (E - U(x)) \psi = 0$

which we write as $\Psi_I'' + k^2 \Psi_I = 0, x < 0$

$$k^2 = \frac{2mE}{\hbar^2}$$

and

$$\Psi_{II}'' + \alpha^2 \Psi_{II} = 0 \quad x > 0$$

$$\alpha^2 = \frac{2m}{\hbar^2} (E - U_0) > 0$$

It is convenient to look for solutions in the form

$$\psi_I = e^{ikx} + R e^{-ikx} \quad x < 0$$

$$\Psi_{II} = A e^{i\alpha x} + B e^{-i\alpha x} \quad x > 0$$

In region $I (x < 0)$, the amplitude of e^{ikx} is written as unity by convention. In II we expect only a transmitted wave to the right, $B = 0$ then. So

$$\Psi_{II} = A e^{i\alpha x} \quad x > 0$$

The boundary conditions follow from the continuity of Ψ & $\frac{d\Psi}{dx}$ at $x = 0$.

$$1 + R = A$$

$$iK(1 - R) = i\alpha A$$

Then

$$\frac{1 - R}{1 + R} = \frac{\alpha}{k} \quad \text{or} \quad R = \frac{k - \alpha}{k + \alpha}$$

The reflection coefficient is the absolute square of R :

$$r = |R|^2 = \left| \frac{k - \alpha}{k + \alpha} \right|^2$$

(b) In this case $E < U_0$, $\alpha^2 = -\beta^2 < 0$. Then Ψ_I is unchanged in form but

$$\Psi_{II} = A e^{-\beta x} + B e^{+\beta x}$$

we must have $B = 0$ since otherwise $\psi(x)$ will become unbounded as $x \rightarrow \infty$.

Finally

$$\Psi_{II} = A e^{-\beta x}$$

Inside the barrier, the particle then has a probability density equal to

$$|\Psi_{II}|^2 = |A|^2 e^{-2\beta x}$$

This decreases to $\frac{1}{e}$ of its value in

$$x_{\text{eff}} = \frac{1}{2\beta} = \frac{\hbar}{2\sqrt{2m(U_0 - E)}}$$

6.95 The formula is

$$D = \exp \left[-\frac{2}{\hbar} \int_{x_1}^{x_2} \sqrt{2m(V(x) - E)} dx \right]$$

Here $V(x_2) = V(x_1) = E$ and $V(x) > E$ in the region $x_2 > x > x_1$.

(a) For the problem, the integral is trivial

$$D = \exp \left[-\frac{2l}{\hbar} \sqrt{2m(U_0 - E)} \right]$$

(b) We can without loss of generality take $x = 0$ at the point the potential begins to climb.

Then

$$U(x) = \begin{cases} 0 & x < 0 \\ U_0 \frac{x}{l} & 0 < x < l \\ 0 & x > l \end{cases}$$

Then

$$\begin{aligned} D &= \exp \left[-\frac{2}{\hbar} \int_{l \frac{E}{U_0}}^l \sqrt{2m \left(U_0 \frac{x}{l} - E \right)} dx \right] \\ &= \exp \left[-\frac{2}{\hbar} \sqrt{\frac{2mU_0}{l}} \int_{x_0}^l \sqrt{x - x_0} dx \right]_{x_0 = l \frac{E}{U_0}} \end{aligned}$$

$$\begin{aligned}
&= \exp \left[-\frac{2}{\hbar} \sqrt{\frac{2mU_0}{l}} \frac{2}{3} (x-x_0)^{3/2} \right]_{x_0}^l \\
&= \exp \left[-\frac{4}{3\hbar} \sqrt{\frac{2mU_0}{l}} \left(l - l \frac{E}{U_0} \right)^{3/2} \right] \\
&= \exp \left[-\frac{4l}{3\hbar U_0} (U_0 - E)^{3/2} \sqrt{2m} \right]
\end{aligned}$$

6.96 The potential is $U(x) = U_0 \left(1 - \frac{x^2}{l^2} \right)$. The turning points are

$$\frac{E}{U_0} = 1 - \frac{x^2}{l^2} \quad \text{or} \quad x = \pm l \sqrt{1 - \frac{E}{U_0}}.$$

Then

$$\begin{aligned}
D &\approx \exp \left[-\frac{4}{\hbar} \int_0^{l\sqrt{1-(E/U_0)}} \sqrt{2m \left\{ U_0 \left(1 - \frac{x^2}{l^2} \right) - E \right\}} dx \right] \\
&= \exp \left[-\frac{4}{\hbar} \int_0^{l\sqrt{1-(E/U_0)}} \sqrt{2mU_0} \sqrt{1 - \frac{E}{U_0} - \frac{x^2}{l^2}} dx \right] \\
&= \exp \left[-\frac{4l}{\hbar} \sqrt{2mU_0} \int_0^{x_0} \sqrt{x_0^2 - x^2} dx \right], \quad x_0 = \sqrt{1 - E/U_0}
\end{aligned}$$

The integral is

$$\int_0^{x_0} \sqrt{x_0^2 - x^2} dx = x_0^2 \int_0^{\pi/2} \cos^2 \theta d\theta = \frac{\pi}{4} x_0^2$$

Thus

$$\begin{aligned}
D &\approx \exp \left[-\frac{\pi l}{\hbar} \sqrt{2mU_0} \left(1 - \frac{E}{U_0} \right) \right] \\
&= \exp \left[-\frac{\pi l}{\hbar} \sqrt{\frac{2m}{U_0}} (U_0 - E) \right]
\end{aligned}$$

6.3 PROPERTIES OF ATOMS. SPECTRA

6.97 From the Rydberg formula we write

$$E_n = - \frac{\hbar R}{(n + \alpha_l)^2}$$

we use $\hbar R = 13.6$ eV. Then for $n = 2$ state

$$5.39 = - \frac{13.6}{(2 + \alpha_0)^2}, \quad l = 0 (S) \text{ state}$$

$$\alpha_0 = - 0.41$$

for p state

$$3.54 = - \frac{13.6}{(2 + \alpha_1)^2}$$

$$\alpha_1 = - 0.039$$

6.98 The energy of the $3p$ state must be $-(E_0 - e\varphi)$ where $-E_0$ is the energy of the $3S$ state. Then

$$E_0 - e\varphi_1 = \frac{\hbar R}{(3 + \alpha_1)^2}$$

so

$$\alpha_1 = \sqrt{\frac{\hbar R}{E_0 - e\varphi_1}} - 3 = - 0.885$$

6.99 For the first line of the sharp series ($3S \rightarrow 2P$) in a Li atom

$$\frac{2\pi\hbar c}{\lambda_1} = - \frac{\hbar R}{(3 + \alpha_0)^2} + \frac{\hbar R}{(2 + \alpha_1)^2}$$

For the short wave cut-off wave-length of the same series

$$\frac{2\pi\hbar c}{\lambda_2} = \frac{\hbar R}{(2 + \alpha_1)^2}$$

From these two equations we get on subtraction

$$\begin{aligned} 3 + \alpha_0 &= \sqrt{\frac{\hbar R}{2\pi\hbar c} \frac{(\lambda_1 - \lambda_2)}{\lambda_1 \lambda_2}} \\ &= \sqrt{\frac{R \lambda_1 \lambda_2}{2\pi c \Delta \lambda}}, \quad \Delta \lambda = \lambda_1 - \lambda_2 \end{aligned}$$

Thus in the ground state, the binding energy of the electron is

$$E_b = \frac{\hbar R}{(2 + \alpha_0)^2} = \hbar R / \left(\sqrt{\frac{R \lambda_1 \lambda_2}{2\pi c \Delta \lambda}} - 1 \right)^2 = 5.32 \text{ eV}$$

6.100 The energy of the 3 *S* state is

$$E(3S) = -\frac{\hbar R}{(3 - 0.41)^2} = -2.03 \text{ eV}$$

The energy of a 2 *S* state is

$$E(2S) = -\frac{\hbar R}{(2 - 0.41)^2} = -5.39 \text{ eV}$$

The energy of a 2 *P* state is

$$E(2P) = -\frac{\hbar R}{(2 - 0.4)^2} = -3.55 \text{ eV}$$

We see that

$$E(2S) < E(2P) < E(3S)$$

The transitions are $3S \rightarrow 2P$ and $2P \rightarrow 2S$.

Direct $3S \rightarrow 2S$ transition is forbidden by selection rules. The wavelengths are determined by

$$E_2 - E_1 = \Delta E = \frac{2\pi\hbar c}{\lambda}$$

Substitution gives

$$\lambda = 0.816 \mu\text{m} (3S \rightarrow 2P)$$

and

$$\lambda = 0.674 \mu\text{m} (2P \rightarrow 2S)$$

6.101 The splitting of the *Na* lines is due to the fine structure splitting of 3 *p* lines (The 3 *s* state is nearly single except for possible hyperfine effects.) The splitting of the 3 *p* level then equals the energy difference

$$\Delta E = \frac{2\pi\hbar c}{\lambda_1} - \frac{2\pi\hbar c}{\lambda_2} = \frac{2\pi\hbar c(\lambda_2 - \lambda_1)}{\lambda_1\lambda_2} \approx \frac{2\pi\hbar c \Delta\lambda}{\lambda^2}$$

Here $\Delta\lambda$ = wavelength difference & λ = average wavelength. Substitution gives

$$\Delta E = 2.0 \text{ meV}$$

6.102 The sharp series arise from the transitions $ns \rightarrow mp$. The *s* lines are unsplit so the splitting is due entirely to the *p* level. The frequency difference between sequent lines is $\frac{\Delta E}{\hbar}$ and is the same for all lines of the sharp series. It is

$$\frac{1}{\hbar} \left(\frac{2\pi\hbar c}{\lambda_1} - \frac{2\pi\hbar c}{\lambda_2} \right) = \frac{2\pi c \Delta\lambda}{\lambda_1\lambda_2}$$

Evaluation gives

$$1.645 \times 10^{14} \text{ rad/s}$$

6.103 We shall ignore hyperfine interaction. The state with principal quantum number $n = 3$ has orbital angular momentum quantum number

$$l = 0, 1, 2$$

The levels with these terms are $3S, 3P, 3D$. The total angular momentum is obtained by combining spin and angular momentum. For a single electron this leads to

$$J = \frac{1}{2}, \text{ if } L = 0$$

$$J = L - \frac{1}{2} \text{ and } L + \frac{1}{2} \text{ if } L \neq 0$$

We then get the final designations

$$3S_{\frac{1}{2}}, 3P_{\frac{1}{2}}, 3P_{\frac{3}{2}}, 3D_{\frac{3}{2}}, 3D_{\frac{5}{2}}.$$

6.104 The rule is that if $\vec{J} = \vec{L} + \vec{S}$ then J takes the values

$$|L - S| \text{ to } L + S$$

in step of 1. Thus :

(a) The values are 1, 2, 3, 4, 5

(b) The values are 0, 1, 2, 3, 4, 5, 6

(c) The values are $\frac{1}{2}, \frac{3}{2}, \frac{5}{2}, \frac{7}{2}, \frac{9}{2}$.

6.105 For the state $4p$, $L = 1$, $S = \frac{3}{2}$ (since $2s + 1 = 4$). For the state $5d$, $L = 2$, $s = 2$.

The possible values of J are

$$J : \frac{5}{2}, \frac{3}{2}, \frac{1}{2} \text{ for } 4p$$

$$J : 4, 3, 2, 1, 0 \text{ for } 5d$$

The value of the magnitude of angular momentum is $\hbar\sqrt{J(J+1)}$. Substitution gives the values

$4P$:

$$\hbar\sqrt{\frac{1}{2} \cdot \frac{3}{2}} = \frac{\hbar\sqrt{3}}{2}, \quad \hbar\sqrt{\frac{3}{2} \cdot \frac{5}{2}} = \frac{\hbar\sqrt{15}}{2}$$

and

$$\hbar\sqrt{\frac{5}{2} \cdot \frac{7}{2}} = \frac{\hbar\sqrt{35}}{2}$$

$$5D : 0, \hbar\sqrt{2}, \hbar\sqrt{6}, \hbar\sqrt{12}, \hbar\sqrt{20}$$

- 6.106** (a) For the Na atoms the valence electron has principal quantum number $n = 4$, and the possible values of orbital angular momentum are $l = 0, 1, 2, 3$ so $l_{\max} = 3$. The state is 2F , maximum value of J is $\frac{7}{2}$.

Thus the state with maximum angular momentum will be

$$\text{For this state} \quad M_{\max} = \hbar \sqrt{\frac{7}{2} \cdot \frac{9}{2}} = \frac{\hbar \sqrt{63}}{2}$$

- (b) For the atom with electronic configuration $1s^2 2p 3d$. There are two inequivalent valence electrons. The total orbital angular momenta will be 1, 2, 3 so we pick $l = 3$. The total spin angular momentum will be $s = 0, 1$ so we pick up $s = 1$. Finally J will be 2, 3, 4 so we pick up 4. Thus maximum angular momentum state is

$$\text{For this state} \quad M_{\max} = \hbar \sqrt{4 \times 5} = 2\hbar \sqrt{5}.$$

- 6.107** For the f state $L = 3$, For the d state $L = 2$. Now if the state has spin s the possible angular momentum are

$$|L - S| \quad \text{to} \quad L + S$$

The number of J angular momentum values is $2S + 1$ if $L \geq S$ and $2L + 1$ if $L < S$. Since the number of states is 5, we must have $S \geq L = 2$ for D state while $S \leq 3$ and $2S + 1 = 5$ in ply $S = 2$ for F state. Thus for the F state total spin angular momentum

$$M_s = \hbar \sqrt{2 \cdot 3} = \hbar \sqrt{6}$$

while for D state

$$M_s \geq \hbar \sqrt{6}.$$

- 6.108** Multiplicity is $2S + 1$ so $S = 1$.

Total angular momentum is $\hbar \sqrt{J(J+1)}$ so $J = 4$. Then

$$L \text{ must equal } 3, 4, 5$$

in order that $J = 4$ may be included in

$$|L - S| \quad \text{to} \quad L + S.$$

- 6.109** (a) Here $J = 2$, $L = 2$. Then $S = 0, 1, 2, 3, 4$ and the multiplicities $(2S + 1)$ are

$$1, 3, 5, 7, 9.$$

- (b) Here $J = 3/2$, $L = 1$ Then $S = \frac{5}{2}, \frac{3}{2}, \frac{1}{2}$

and the multiplicities are $6, 4, 2$

- (c) Here $J = 1$, $L = 3$. Then $S = 2, 3, 4$

and the multiplicities are $5, 7, 9$

6.110 The total angular momentum is greatest when L, S are both greatest and add to form J . Now for a triplet of s, p, d electrons

Maximum spin $\rightarrow S = \frac{3}{2}$ corresponding to

$$M_s = \hbar \sqrt{\frac{3}{2} \cdot \frac{5}{2}} = \frac{\hbar \sqrt{15}}{2}$$

Maximum orbital angular momentum \rightarrow

$$L = 3$$

corresponding to

$$M_L = \hbar \sqrt{\frac{3}{2} \cdot \frac{5}{2}} = \frac{\hbar \sqrt{15}}{2}$$

Maximum total angular momentum $J = \frac{9}{2}$

corresponding to

$$M = \frac{\hbar}{2} \sqrt{99}$$

In vector model

$$\vec{L} = \vec{J} - \vec{S}$$

or in magnitude squared

$$L(L+1)\hbar^2 = J(J+1)\hbar^2 + S(S+1)\hbar^2 - 2\vec{J} \cdot \vec{S}$$

Thus $\cos(\angle \vec{J}, \vec{S}) = \frac{J(J+1) + S(S+1) - L(L+1)}{2\sqrt{J(J+1)}\sqrt{S(S+1)}}$

Substitution gives

$$\angle(\vec{J}, \vec{S}) = 31.1^\circ.$$

6.111 Total angular momentum $\hbar\sqrt{6}$ means $J = 2$. It gives that $S = 1$. This means that $L = 1, 2$, or 3 . From vector model relation

$$\begin{aligned} L(L+1)\hbar^2 &= 6\hbar^2 + 2\hbar^2 - 2\hbar^2\sqrt{6}\sqrt{2} \cos 73.2^\circ \\ &= 5.998\hbar^2 \approx 6\hbar^2 \end{aligned}$$

Thus $L = 2$ and the spectral symbol of the state is

$${}^3D_2.$$

6.112 In a system containing a p electron and a d electron

$$S = 0, 1$$

$$L = 1, 2, 3$$

For $S = 0$ we have the terms

$${}^1P_1, {}^1D_2, {}^1F_3$$

For $S = 1$ we have the terms

$${}^3P_0, {}^3P_1, {}^3P_2, {}^3D_1, {}^3D_2, {}^3D_3, {}^3F_2, {}^3F_3, {}^3F_4$$

6.113 The atom has $S_1 = 1/2$, $l_1 = 1$, $j_1 = \frac{3}{2}$

The electron has $S_2 = \frac{1}{2}$, $l_2 = 2$ so the total angular momentum quantum number must be

$$j_2 = \frac{3}{2} \text{ or } \frac{5}{2}$$

In $L-S$ coupling we get $S = 0, 1$. $L = 1, 2, 3$ and the terms that can be formed are the same as written in the problem above. The possible values of angular momentum are consistent with the addition $j_1 = \frac{3}{2}$ to $j_2 = \frac{3}{2}$ or $\frac{5}{2}$.

The latter gives us $J = 0, 1, 2, 3$; $1, 2, 3, 4$

All these values are reached above.

6.114 Selection rules are $\Delta S = 0$

$$\Delta L = \pm 1$$

$$\Delta J = 0, \pm 1 \text{ (no } 0 \rightarrow 0 \text{)}.$$

Thus

$${}^2D_{3/2} \rightarrow {}^2P_{1/2} \text{ is allowed}$$

$${}^3P_1 \rightarrow {}^2S_{1/2} \text{ not allowed}$$

$${}^3F_3 \rightarrow {}^3P_2 \text{ is not allowed } (\Delta L = 2)$$

$${}^4F_{7/2} \rightarrow {}^4D_{5/2} \text{ is allowed}$$

6.115 For a 3 d state of a Li atom, $S = \frac{1}{2}$ because there is only one electron and $L = 2$.

The total degeneracy is

$$g = (2L + 1)(2S + 1) = 5 \times 2 = 10.$$

The states are ${}^2D_{3/2}$ and ${}^2D_{5/2}$ and we check that

$$g = 4 + 6 = \left(2 \times \frac{3}{2} + 1\right) + \left(2 \times \frac{5}{2} + 1\right)$$

6.116 The state with greatest possible total angular momentum are

For a 2P state $J = \frac{1}{2} + 1 = \frac{3}{2}$ i.e. ${}^2P_{3/2}$

Its degeneracy is 4.

For a 3D state $J = 1 + 2 = 3$ i.e. 3D_3

Its degeneracy is $2 \times 3 + 1 = 7$

For a 4F state $J = \frac{3}{2} + 3 = \frac{9}{2}$ i.e. ${}^4F_{4}$.

Its degeneracy is $2 \times \frac{9}{2} + 1 = 10$.

6.117 The degeneracy is $2J + 1$. So we must have $J = 3$. From $L = 3S$, we see that S must be an integer since L is integral and S can be either integral or half integral. If $S = 0$ then $L = 0$ but this is consistent with $J = 3$. For $S \geq 2$, $L \geq 6$ and then $J \neq 3$. Thus the state is

$3F_3$

6.118 The order of filling is

K, L, M shells, then $4s^2, 3d^{10}$ then $4p^3$. The electronic configuration of the element will be

$$1s^2 2s^2 2p^6 3s^2 3p^6 4s^2 3d^{10} 4p^3$$

(There must be three $4p$ electrons)

The number of electrons is $Z = 33$ and the element is As. (The $3d$ subshell must be filled before $4p$ fills up.)

6.119 (a) when the partially filled shell contains three p electrons, the total spin S must equal

$S = \frac{1}{2}$ or $\frac{3}{2}$. The state $S = \frac{3}{2}$ has maximum spin and is totally symmetric under exchange of spin labels. By Pauli's exclusion principle this implies that the angular part of the wavefunction must be totally antisymmetric. Since the angular part of the wavefunction a p electron is vector \vec{r}_i , the total wavefunction of three p electrons is the totally antisymmetric combination of \vec{r}_1, \vec{r}_2 , and \vec{r}_3 . The only such combination is

$$\vec{r}_1 \cdot (\vec{r}_2 \times \vec{r}_3) = \begin{vmatrix} x_1 & x_2 & x_3 \\ y_1 & y_2 & y_3 \\ z_1 & z_2 & z_3 \end{vmatrix}$$

This combination is a scalar and hence has $L = 0$. The spectral term of the ground state is then

$${}^4S_{\frac{3}{2}} \quad \text{since } J = \frac{3}{2}.$$

(b) We can think of four p electrons as consisting of a full p shell with two p holes. The state of maximum spin S is then $S = 1$. By Pauli's principle the orbital angular momentum part must be antisymmetric and can only have the form

$$\vec{r}_1 \times \vec{r}_2$$

where \vec{r}_1, \vec{r}_2 are the coordinates of holes. The result is harder to see if we do not use the concept of holes. Four p electrons can have $S = 0, 1, 2$ but the $S = 2$ state is totally symmetric. The corresponding angular wavefunction must be totally antisymmetric. But this is impossible: there is no quantity which is antisymmetric in four vectors. Thus the maximum allowed S is $S = 1$. We can construct such a state by coupling the spins of electrons 1 & 2 to $S = 1$ and of electrons 3 & 4 to $S = 1$ and then coupling the resultant spin states to $S = 1$. Such a state is symmetric under the exchange of spins of 1 & 2 and 3 and 4 but antisymmetric under the simultaneous exchange of (1, 2) & (3, 4). the con-

jugate angular wavefunction must be antisymmetric under the exchange of (1, 2) and under the exchange of (3, 4) by Pauli principle. It must also be antisymmetric under the simultaneous exchange of (1, 2) and (3, 4). (This is because two exchanges of electrons are involved.) The required angular wavefunction then has the form

$$(\vec{r}_1 \times \vec{r}_2) \times (\vec{r}_3 \times \vec{r}_4)$$

and is a vector, $L = 1$. Thus, using also the fact that the shell is more than half full, we find the spectral term 3P_2

$$(J = L + S).$$

- 6.120 (a)** The maximum spin angular momentum of three electrons can be $S = \frac{3}{2}$. This state is totally symmetric and hence the conjugate angular wavefunction must be antisymmetric. By Pauli's exclusion principle the totally antisymmetric state must have different magnetic quantum numbers. It is easy to see that for d electrons the maximum value of the magnetic quantum number for orbital angular momentum $|M_{Lz}| = 3$ (from $2 + 1 + 0$). Higher values violate Pauli's principle. Thus the state of highest orbital angular momentum consistent with Pauli's principle is $L = 3$.

The state of the atom is then 4F_J where $J = L - S$ by Hund's rule. Thus we get

$${}^4F_{3/2}$$

The magnitude of the angular momentum is

$$\hbar \sqrt{\frac{3}{2} \cdot \frac{5}{2}} = \frac{\hbar}{2} \sqrt{15}.$$

- (b)** Seven d electrons mean three holes. Then $S = \frac{3}{2}$ and $L = 3$ as before. But

$J = L + S = \frac{9}{2}$ by Hund's rule for more than half filled shell. Thus the state is

$${}^4F_{9/2}$$

Total angular momentum has the magnitude

$$\hbar \sqrt{\frac{9}{2} \cdot \frac{11}{2}} = \frac{3\hbar}{2} \sqrt{11}.$$

- 6.121 (a)** 3F_2 : The maximum value of spin is $S = 1$ here. This means there are 2 electrons. $L = 3$ so s and p electrons are ruled out. Thus the simplest possibility is d electrons. This is the correct choice for if we were considering f electrons, the maximum value of L allowed by Pauli principle will be $L = 5$ (maximum value of the magnitude of magnetic quantum number will be $3 + 2 = 5$.)

Thus the atom has two d electrons in the unfilled shell.

- (b)** ${}^2P_{3/2}$ Here $L = 1$, $S = \frac{1}{2}$ and $J = \frac{3}{2}$

Since $J = L + S$, Hund's rule implies the shell is more than half full. This means one electron less than a full shell. On the basis of hole picture it is easy to see that we have p electrons. Thus the atom has 5 p electrons.

- (c) ${}^6S_{5/2}$ Here $S = \frac{5}{2}$, $L = 0$. We either have five electrons or five holes. The angular part is antisymmetric. For five d electrons, the maximum value of the quantum number consistent with Pauli exclusion principle is $(2 + 1 + 0 - 1 - 2) = 0$ so $L = 0$. For f or g electrons $L > 0$ whether the shell has five electrons or five holes. Thus the atom has five d electrons.

6.122 (a) If $S = 1$ is the maximum spin then there must be two electrons (If there are two holes then the shell will be more than half full.). This means that there are 6 electrons in the full shell so it is a p shell. By Paul's principle the only antisymmetric combination of two electrons has $L = 1$ Also $J = L - S$ as the shell is less than half full. Thus the term is 3P_0

- (b) $S = \frac{3}{2}$ means either 3 electrons or 3 holes. As the shell is more than half full the former possibility is ruled out. Thus we must have seven d electrons. Then as in problem 6.120 we get the term ${}^4F_{9/2}$

6.123 With three electrons $S = \frac{3}{2}$ and the spin part is totally symmetric. It is given that the basic term has $L = 3$ so $L = 3$ is the state of highest orbital angular momentum. This is not possible with p electron so we must have d electrons for which $L = 3$ for 3 electrons. For three f, g electrons $L > 3$. Thus we have 3 d electrons. Then as in (6.120) the ground state is

$${}^4F_{3/2}$$

6.124 We have 5 d electrons in the only unfilled shell. Then $S = \frac{5}{2}$. Maximum value of L consistent with Pauli's principle is $L = 0$. Then $J = \frac{5}{2}$.

So by Lande's formula

$$g = 1 + \frac{\frac{5}{2} \left(\frac{7}{2} \right) + \frac{5}{2} \left(\frac{7}{2} \right) - 0}{2 \frac{5}{2} \left(\frac{7}{2} \right)} = 2$$

Thus $\mu = g \sqrt{J(J+1)} \mu_B = 2 \frac{\sqrt{35}}{2} \mu_B = 2\sqrt{35} \mu_B$.

The ground state is ${}^6S_{5/2}$.

6.125 By Boltzmann formula

$$\frac{N_2}{N_1} = \frac{g_2}{g_1} e^{-\Delta E/KT}$$

Here ΔE = energy difference between $n = 1$ and $n = 2$ states

$$= 13.6 \left(1 - \frac{1}{4} \right) \text{eV} = 10.22 \text{eV}$$

$g_1 = 2$ and $g_2 = 8$ (counting $2s$ & $2P$ states.) Thus

$$\frac{N_2}{N_1} = 4 e^{-10.22 \times 1.602 \times 10^{-19} / 1.38 \times 10^{-23} \times 3000} = 2.7 \times 10^{-17}$$

Explicitly $\eta = \frac{N_2}{N_1} = n^2 e^{-\Delta E_n/KT}$, $\Delta E_n = \hbar R \left(1 - \frac{1}{n^2} \right)$

for the n th excited state because the degeneracy of the state with principal quantum number n is $2n^2$.

6.126 We have

$$\frac{N}{N_0} = \frac{g}{g_0} e^{-h\omega/kT} = \frac{g}{g_0} e^{-2\pi\hbar c/\lambda kT}$$

Here g = degeneracy of the $3P$ state = 6, g_0 = degeneracy of the $3S$ state = 2 and

λ = wavelength of the $3P \rightarrow 3S$ line $\left(\frac{2\pi\hbar c}{\lambda} = \text{energy difference between } 3P \text{ \& } 3S \text{ levels.} \right)$

Substitution gives
$$\frac{N}{N_0} = 1.13 \times 10^{-4}$$

6.127 Let T = mean life time of the excited atoms. Then the number of excited atoms will decrease with time as $e^{-t/T}$. In time t the atom travels a distance $v t$ so $t = \frac{l}{v}$. Thus the number of excited atoms in a beam that has traversed a distance l has decreased by

$$e^{-l/vT}$$

The intensity of the line is proportional to the number of excited atoms in the beam. Thus

$$e^{-l/v\tau} = \frac{1}{\eta} \text{ or } \tau = \frac{l}{v \ln \eta} = 1.29 \times 10^{-6} \text{ second.}$$

6.128 As a result of the lighting by the mercury lamp a number of atoms are pumped to the excited state. In equilibrium the number of such atoms is N . Since the mean life time of the atom is T , the number decaying per unit time is $\frac{N}{\tau}$. Since a photon of energy $\frac{2\pi\hbar c}{\lambda}$ results from

each decay, the total radiated power will be $\frac{2\pi\hbar c}{\lambda} \cdot \frac{N}{\tau}$. This must equal P . Thus

$$N = P\tau / \frac{2\pi\hbar c}{\lambda} = \frac{P\tau\lambda}{2\pi\hbar} = 6.7 \times 10^9$$

6.129 The number of excited atoms per unit volume of the gas in $2P$ state is

$$N = n \frac{g_p}{g_s} e^{-2\pi h c / \lambda k T}$$

Here g_p = degeneracy of the $2p$ state = 6, g_s = degeneracy of the $2s$ state = 2 and λ = wavelength of the resonant line $2p \rightarrow 2s$. The rate of decay of these atoms is $\frac{N}{\tau}$ per sec. per unit volume. Since each such atom emits light of wavelength λ , we must have

$$\frac{1}{\tau} \frac{2\pi h c}{\lambda} n \frac{g_p}{g_s} e^{-2\pi h c / \lambda k T} = P$$

Thus $\tau = \frac{1}{P} \frac{2\pi h c}{\lambda} n \frac{g_p}{g_s} e^{-2\pi h c / \lambda k T} = 65.4 \times 10^{-9} \text{ s} = 65.4 \text{ ns}$

6.130 (a) We know that

$$P_{21}^{sp} = A_{21}$$

$$P_{21}^{ind} = B_{21} u_{as}$$

$$= \frac{\pi^2 c^3}{h \omega^3} A_{21} \cdot \frac{h \omega^3}{\pi^2 c^3} \frac{1}{e^{-h/kT} - 1} = \frac{A_{21}}{e^{-h \omega / kT} - 1}$$

Thus
$$\frac{P_{21}^{ind}}{P_{21}^{sp}} = \frac{1}{e^{-h \omega / kT} - 1}$$

For the transition $2P \rightarrow 1S$ $h \omega = \frac{3}{4} h R$ and

we get
$$\frac{P_{21}^{in}}{P_{21}^{sp}} = e^{-h \omega / kT}$$

substitution gives 7×10^{-18}

(b) The two rates become equal when $e^{-h \omega / kT} = 2$

or
$$T = (h \omega / k \ln 2) = 1.71 \times 10^5 \text{ K}$$

6.131 Because of the resonant nature of the processes we can ignore nonresonant processes. We also ignore spontaneous emission since it does not contribute to the absorption coefficient and is a small term if the beam is intense enough.

Suppose I is the intensity of the beam at some point. The decrease in the value of this intensity on passing through the layer of the substance of thickness dx is equal to

$$-dI = XI dx = (N_1 B_{12} - N_2 B_{21}) \left(\frac{I}{c}\right) h \omega dx$$

Here N_1 = No. of atoms in lower level

N_2 = No of atoms in the upper level per unit volume.

B_{12} , B_{21} are Einstein coefficients and I_c = energy density in the beam, c = velocity of light.

A factor $\hbar \omega$ arises because each transition result in a loss or gain of energy $\hbar \omega$

Hence
$$x = \frac{\hbar \omega}{c} N_1 B_{12} \left(1 - \frac{N_2 B_{21}}{N_1 B_{12}} \right)$$

But
$$g_1 B_{12} = g_2 B_{21} \text{ so}$$

$$x = \frac{\hbar \omega}{c} N_1 B_{12} \left(1 - \frac{g_1 N_2}{g_2 N_1} \right)$$

By Boltzman factor
$$\frac{N_2}{N_1} = \frac{g_2}{g_1} e^{-\hbar \omega / k T}$$

When $\hbar \omega \gg k T$ we can put $N_1 = N_0$ the total number of atoms per unit volume.

Then
$$x = x_0 \left(1 - e^{-\hbar \omega / k T} \right)$$

where $x_0 = \frac{\hbar \omega}{c} N_0 B_{12}$ is the absorption coefficient for $T \rightarrow 0$.

6.132 A short lived state of mean life T has an uncertainty in energy of $\Delta E \sim \frac{\hbar}{T}$ which is transmitted to the photon it emits as natural broadening. Then

$$\Delta \omega_{nat} = \frac{1}{T} \quad \text{so} \quad \Delta \lambda_{nat} = \frac{\lambda^2}{2 \pi c \tau}$$

The Döppler broadening on the other hand arises from the thermal motion of radiating atoms. The effect is non-relativistic and the maximum broadening can be written as

$$\frac{\Delta \lambda_{Dop}}{\lambda} = 2 \beta = \frac{2 v_{pr}}{c}$$

Thus
$$\frac{\Delta \lambda_{Dopp}}{\Delta \lambda_{nat}} = \frac{4 \pi v_{pr} \tau}{\lambda}$$

Substitution gives using $v_{pr} = \sqrt{\frac{2 R T}{M}} = 157 \text{ m/s}$,

$$\frac{\Delta \lambda_{Dopp}}{\Delta \lambda_{nat}} \approx 1.2 \times 10^3$$

Note :- Our formula is an order of magnitude estimate.

6.133 From Moseley's law

$$\omega_{K_\alpha} = \frac{3}{4} R (Z - 1)^2$$

or
$$\lambda_{K_\alpha} = \frac{4}{3 R (Z - 1)^2}$$

Thus
$$\frac{\lambda_{K_\alpha} (Cu)}{\lambda_{K_\alpha} (Fe)} = \left(\frac{25}{28} \right)^2 = \left(\frac{Z_{Fe} - 1}{Z_{Cu} - 1} \right)^2$$

Substitution gives

$$\lambda_{K_{\alpha}}(\text{Cu}) = 153.9 \text{ pm}$$

6.134 (a) From Moseley's law

$$\omega_{K_{\alpha}} = \frac{3}{4} R (Z - \sigma)^2$$

or

$$\lambda_{K_{\alpha}} = \frac{2\pi c}{\omega_{K_{\alpha}}} = \frac{8\pi c}{3R} \frac{1}{(Z - \sigma)^2}$$

We shall take $\sigma = 1$. For Aluminium ($Z = 13$)

$$\lambda_{K_{\alpha}}(\text{Al}) = 843.2 \text{ pm}$$

and for cobalt ($Z = 27$)

$$\lambda_{K_{\alpha}}(\text{Co}) = 179.6 \text{ pm}$$

(b) This difference is nearly equal to the energy of the K_{α} line which by Moseley's law is equal to ($Z = 23$ for vanadium)

$$\Delta E = \hbar \omega_{K_{\alpha}} = \frac{3}{4} \times 13.62 \times 22 \times 22 = 4.94 \text{ keV}$$

6.135 We calculate the Z values corresponding to the given wavelengths using Moseley's law. See problem (134).

Substitution gives that

$$Z = 23 \text{ corresponding to } \lambda = 250 \text{ pm}$$

and

$$Z = 27 \text{ corresponding to } \lambda = 179 \text{ pm}$$

There are thus three elements in a row between those whose wavelengths of K_{α} lines are equal to 250 pm and 179 pm.

6.136 From Moseley's law

$$\lambda_{K_{\alpha}}(\text{Ni}) = \frac{8\pi c}{3R} \frac{1}{(Z - 1)^2}$$

where $Z = 28$ for Ni . Substitution gives

$$\lambda_{K_{\alpha}}(\text{Ni}) = 166.5 \text{ pm}$$

Now the short wave cut of off the continuous spectrum must be more energetic (smaller wavelength) otherwise K_{α} lines will not emerge. Then since $\Delta \lambda = \lambda_{K_{\alpha}} - \lambda_0 = 84 \text{ pm}$ we get

$$\lambda_0 = 82.5 \text{ pm}$$

This corresponds to a voltage of

$$V = \frac{2\pi\hbar c}{e\lambda_0}$$

Substitution gives $V = 15.0 \text{ kV}$

6.137 Since the short wavelength cut off of the continuous spectrum is

$$\lambda_0 = 0.50 \text{ nm}$$

the voltage applied must be $V = \frac{2\pi\hbar c}{e\lambda_0} = 2.48 \text{ kV}$,

since this is greater than the excitation potential of the K series of the characteristic spectrum (which is only 1.56 kV) the latter will be observed.

6.138 Suppose λ_0 = wavelength of the characteristic X -ray line. Then using the formula for short wavelength limit of continuous radiation

$$\frac{\lambda_0 - \frac{2\pi\hbar c}{eV_1}}{\lambda_0 - \frac{2\pi\hbar c}{eV_2}} = \frac{1}{n}$$

Hence

$$\lambda_0 = \frac{2\pi\hbar c}{eV_1} \frac{\left(n - \frac{V_1}{V_2}\right)}{n-1}$$

Using also Moseley's law, we get

$$Z = 1 + \sqrt{\frac{8\pi c}{3R\lambda}} = 1 + 2\sqrt{\frac{n-1}{3\hbar R} \frac{eV_1}{n - \frac{V_1}{V_2}}} = 29.$$

6.139 The difference in frequencies of the K and L absorption edges is equal, according to the Bohr picture, to the frequency of the K_α line (see the diagram below). Thus by Moseley's formulæ

$$\Delta\omega = \frac{3}{4}R(Z-1)^2$$

or $Z = 1 + \sqrt{\frac{4\Delta\omega}{3R}} = 22$

The metal is titanium.

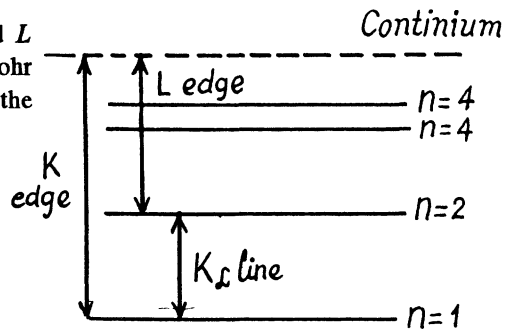

6.140 From the diagram above we see that the binding energy E_b of a K electron is the sum of the energy of a K_α line and the energy corresponding to the L edge of absorption spectrum

$$E_b = \frac{2\pi\hbar c}{\lambda_L} + \frac{3}{4}\hbar R(Z-1)^2$$

For vanadium $Z = 23$ and the energy of K_α line of vanadium has been calculated in problem 134 (b). Using

$$\frac{2\pi\hbar c}{\lambda_L} = 0.51 \text{ keV for } \lambda_L = 2.4 \text{ nm}$$

we get

$$E_b = 5.46 \text{ keV}$$

6.141 By Moseley's law

$$\hbar \omega = \frac{2 \pi \hbar c}{\lambda} E_K - E_L = \frac{3}{4} \hbar R (Z - 1)^2$$

where $-E_K$ is the energy of the K electron and $-E_L$ of the L electron. Also the energy of the line corresponding to the short wave cut off of the K series is

$$\begin{aligned} E_K &= \frac{2 \pi \hbar c}{\lambda - \Delta \lambda} = \frac{2 \pi \hbar c}{\frac{\omega}{\omega} - \Delta \lambda} \\ &= \frac{\hbar}{\frac{1}{\omega} - \frac{\Delta \lambda}{2 \pi c}} = \frac{\hbar \omega}{1 - \frac{\omega \Delta \lambda}{2 \pi c}} \end{aligned}$$

Hence

$$E_L = \frac{\hbar \omega}{1 - \frac{\omega \Delta \lambda}{2 \pi c}} - \hbar \omega = \frac{\hbar \omega}{\frac{\omega \Delta \lambda}{2 \pi c} - 1}$$

Substitution gives for titanium ($Z = 22$)

$$\omega = 6.85 \times 10^{18} \text{ s}^{-1}$$

and hence $E_L = 0.47 \text{ keV}$

6.142 The energy of the K_α radiation of Zn is

$$\hbar \omega = \frac{3}{4} \hbar R (Z - 1)^2$$

where $Z =$ atomic number of Zinc $= 30$. The binding energy of the K electrons in iron is obtained from the wavelength of K absorption edge as $E_K = 2 \pi \hbar c / \lambda_K$

Hence by Einstein equation

$$T = \frac{3}{4} \hbar R (Z - 1)^2 - \frac{2 \pi \hbar c}{\lambda_K}$$

Substitution gives

$$T = 1.463 \text{ keV}$$

This corresponds to a velocity of the photo electrons of

$$v = 2.27 \times 10^6 \text{ m/s}$$

6.143 From the Lande formula

$$g = 1 + \frac{J(J+1) + S(S+1) - L(L+1)}{2J(J+1)}$$

(a) For S states $L = 0$. This implies $J = S$. Then, if $S \neq 0$

$$g = 2$$

(For singlet states g is not defined if $L = 0$)

(b) For singlet states, $J = L$

$$g = 1 + \frac{J(J+1) - L(L+1)}{2J(J+1)} = 1$$

6.144 (a) ${}^6F_{\frac{1}{2}}$ Here $S = \frac{5}{2}$, $L = 3$, $J = \frac{1}{2}$

$$g = 1 + \frac{\frac{3}{4} + \frac{35}{4} - 12}{2 \times \frac{3}{4}} = 1 + \frac{38 - 48}{6} = -\frac{2}{3}$$

(b) ${}^4D_{1/2}$: Here $S = \frac{3}{2}$, $L = 2$, $J = \frac{1}{2}$

$$g = 1 + \frac{\frac{3}{4} + \frac{15}{4} - 6}{2 \times \frac{3}{4}} = 1 + \frac{18 - 24}{6} = 0$$

(c) 5F_2 Here $S = 2$, $L = 3$, $J = 2$

$$g = 1 + \frac{6 + 6 - 12}{2 \times 6} = 1$$

(d) 5P_1 Here $S = 2$, $L = 1$, $J = 1$

$$g = 1 + \frac{2 + 6 - 2}{2 \times 2} = \frac{5}{2}$$

(e) 3P_0 . For states with $J = 0$, $L = S$ the g factor is indeterminate.

6.145 (a) For the 1F state $S = 0$, $L = 3 = J$

$$g = 1 + \frac{3 \times 4 - 3 \times 4}{2 \times 3 \times 4} = 1$$

Hence

$$\mu = \sqrt{3 \times 4} \mu_B = 2\sqrt{3} \mu_B$$

(b) For the ${}^2D_{3/2}$ state $S = \frac{1}{2}$, $L = 2$, $J = \frac{3}{2}$

$$g = 1 + \frac{\frac{15}{4} + \frac{3}{4} - 6}{2 \times \frac{15}{4}} = 1 + \frac{18 - 24}{30} = \frac{4}{5}$$

Hence

$$\mu = \frac{4}{5} \sqrt{15/4} \mu_B = \frac{2}{5} \sqrt{15} \mu_B = 2 \sqrt{\frac{3}{5}} \mu_B.$$

(c) We have

$$\frac{4}{3} = 1 + \frac{J(J+1)+2-6}{2J(J+1)}$$

or
$$\frac{4}{3}J(J+1) = J(J+1) - 4$$

or
$$J(J+1) = 12 \Rightarrow J = 3$$

Hence
$$\mu = \frac{4}{3}\sqrt{12} \mu_B = \frac{8}{\sqrt{3}} \mu_B.$$

6.146 The expression for the projection of the magnetic moment is

$$\mu_z = g m_j \mu_B$$

where m_j is the projection of \vec{J} on the z -axis.

Maximum value of the m_j is J . Thus

$$gJ = 4$$

Since $J = 2$, we get $g = 2$. Now

$$2 = 1 + \frac{J(J+1) + S(S+1) - L(L+1)}{2J(J+1)}$$

$$= 1 + \frac{6 + S(S+1) - 6}{2 \times 6}, \text{ as } L = 2$$

$$= 1 + \frac{S(S+1)}{12}$$

Hence
$$S(S+1) = 12 \text{ or } S = 3$$

Thus
$$M_S = \hbar \sqrt{3 \times 4} = 2\sqrt{3} \hbar$$

6.147 The angle between the angular momentum vector and the field direction is the least when the angular momentum projection is maximum i.e. $J\hbar$.

Thus
$$J\hbar = \sqrt{J(J+1)} \hbar \cos 30^\circ$$

or
$$\sqrt{\frac{J}{J+1}} = \frac{\sqrt{3}}{2}$$

Hence
$$J = 3$$

Then
$$g = 1 + \frac{3 \times 4 + 1 \times 2 - 2 \times 3}{2 \times 3 \times 4} = 1 + \frac{8}{24} = \frac{4}{3}$$

and
$$\mu = \frac{4}{3}\sqrt{3 \times 4} \mu_B = \frac{8}{\sqrt{3}} \mu_B.$$

6.148 For a state with $n = 3$, $l = 2$. Thus the state with maximum angular momentum is

$${}^2D_{5/2}$$

Then

$$g = 1 + \frac{\frac{5}{2} \times \frac{7}{2} + \frac{1}{2} \times \frac{3}{2} - 2 \times 3}{2 \times \frac{5}{2} \times \frac{7}{2}}$$

$$= 1 + \frac{35 + 3 - 24}{70} = 1 + \frac{1}{5} = \frac{6}{5}.$$

Hence

$$\mu = \frac{6}{5} \sqrt{\frac{5}{2} \times \frac{7}{2}} \mu_B = 3 \sqrt{\frac{7}{5}} \mu_B.$$

6.149 To get the greatest possible angular momentum we must have $S = S_{\max} = 1$

$$L = L_{\max} = 1 + 2 = 3 \text{ and } J = L + S = 4$$

Then

$$g = 1 + \frac{4 \times 5 + 1 \times 2 - 3 \times 4}{2 \times 4 \times 5} = 1 + \frac{10}{40} = \frac{5}{4}$$

and

$$\mu = \frac{5}{4} \sqrt{4 \times 5} \mu_B = \frac{5\sqrt{5}}{2} \mu_B.$$

6.150 Since $\mu = 0$ we must have either $J = 0$ or $g = 0$. But $J = 0$ is incompatible with $L = 2$ and $S = \frac{3}{2}$. Hence $g = 0$. Thus

$$0 = 1 + \frac{J(J+1) + \frac{3}{2} \times \frac{5}{2} - 2 \times 3}{2J(J+1)}$$

or

$$-3J(J+1) = \frac{15}{4} - 6 = -\frac{9}{4}$$

Hence

$$J = \frac{1}{2}$$

Thus

$$M = \hbar \sqrt{\frac{1}{2} \times \frac{3}{2}} = \frac{\hbar \sqrt{3}}{2}$$

6.151 From $M = \hbar \sqrt{J+1} = \sqrt{2} \hbar$

we find $J = 1$. From the zero value of the magnetic moment we find

$$g = 0$$

or

$$1 + \frac{1 \times 2L(L+1) + 2 \times 3}{2 \times 1 \times 2} = 0$$

$$1 + \frac{-L(L+1) + 8}{4} = 0$$

or

$$12 = L(L+1)$$

Hence $L = 3$. The state is

$${}^5F_1.$$

6.152 If \vec{M} is the total angular momentum vector of the atom then there is a magnetic moment

$$\vec{\mu}_m = g \mu_B \vec{M} / \hbar$$

associated with it; here g is the Lande factor. In a magnetic field of induction \vec{B} , an energy

$$H' = -g \mu_B \vec{M} \cdot \vec{B} / \hbar$$

is associated with it. This interaction term corresponds to a precession of the angular momentum vector because it leads to an equation of motion of the angular momentum vector of the form

$$\frac{d\vec{M}}{dt} = \vec{\Omega} \times \vec{M}$$

where

$$\vec{\Omega} = \frac{g \mu_B \vec{B}}{\hbar}$$

Using Gaussian unit expression of μ_B $\mu_B = 0.927 \times 10^{-20}$ erg/gauss, $B = 10^3$ gauss
 $\hbar = 1.054 \times 10^{-27}$ erg sec and for the ${}^2P_{3/2}$ state

$$g = 1 + \frac{\frac{3}{2} \times \frac{5}{2} + \frac{1}{2} \times \frac{3}{2} - 1 \times 2}{2 \times \frac{3}{2} \times \frac{5}{2}} = 1 + \frac{1}{3} = \frac{4}{3}$$

and

$$\Omega = 1.17 \times 10^{10} \text{ rad/s}$$

The same formula is valid in MKS units also But $\mu_B = 0.927 \times 10^{-23}$ A·m², $B = 10^{-1}$ T and
 $\hbar = 1.054 \times 10^{-34}$ Joule sec. The answer is the same.

6.153 The force on an atom with magnetic moment $\vec{\mu}$ in a magnetic field of induction \vec{B} is given by

$$\vec{F} = (\vec{\mu} \cdot \vec{\nabla}) \vec{B}$$

In the present case, the maximum force arise when $\vec{\mu}$ is along the axis or close to it.

Then

$$F_z = (\mu_z)_{\max} \frac{\partial B}{\partial z}$$

Here $(\mu_z)_{\max} = g \mu_B J$. The Lande factor g is for ${}^2P_{1/2}$

$$g = 1 + \frac{\frac{1}{2} \times \frac{3}{2} + \frac{1}{2} \times \frac{3}{2} - 1 \times 2}{2 \times \frac{1}{2} \times \frac{3}{2}} = 1 - \frac{1/2}{3/2} = \frac{2}{3}.$$

and

$$J = \frac{1}{2} \text{ so } (\mu_z)_{\max} = \frac{1}{3} \mu_B.$$

The magnetic field is given by

$$B_z = \frac{\mu_0}{4\pi} \cdot \frac{2I\pi r^2}{(r^2 + z^2)^{3/2}}$$

or
$$\frac{\partial B_z}{\partial z} = -\frac{\mu_0}{4\pi} 6 I \pi r^2 \frac{z}{(r^2 + z^2)^{5/2}}.$$

Thus
$$\left(\frac{\partial B_z}{\partial z}\right)_{z=r} = \frac{\mu_0}{4\pi} \frac{3 I \pi}{\sqrt{8} r^2}.$$

Thus the maximum force is

$$F = \frac{1}{3} \mu_B \frac{\mu_0}{4\pi} \frac{3\pi}{\sqrt{8}} \frac{I}{r^2}$$

Substitution gives (using data in MKS units)

$$F = 4.1 \times 10^{-27} \text{ N}$$

6.154 The magnetic field at a distance r from a long current carrying wire is mostly tangential and given by

$$B_\phi = \frac{\mu_0 I}{2\pi r} = \frac{\mu_0}{4\pi} \frac{2I}{r}.$$

The force on a magnetic dipole of moment $\vec{\mu}$ due to this magnetic field is also tangential and has a magnitude

$$(\vec{\mu} \cdot \nabla) B_\phi$$

This force is nonvanishing only when the component of $\vec{\mu}$ along \vec{r} non zero. Then

$$F = \mu_r \frac{\partial}{\partial r} B_\phi = -\mu_r \frac{\mu_0}{4\pi} \frac{2I}{r^2}$$

Now the maximum value of $\mu_r = \pm \mu_B$. Thus the force is

$$F_{\max} = \mu_B \frac{\mu_0}{4\pi} \frac{2I}{r^2} = 2.97 \times 10^{-26} \text{ N}$$

6.155 In the homogeneous magnetic field the atom experiences a force

$$F = gJ \mu_B \frac{\partial B}{\partial z}$$

Depending on the sign of J , this can be either upward or downward. Suppose the latter is true. The atom then traverses first along a parabola inside the field and, once outside, in a straight line. The total distance between extreme lines on the screen will be

$$\delta = 2gJ\mu_B \frac{\partial B}{\partial z} \left\{ \frac{1}{2} \left(\frac{l_1}{v}\right)^2 + \frac{l_1}{v} \cdot \frac{l_2}{v} \right\} / m_V$$

Here m_V is the mass of the vanadium atom. (The first term is the displacement within the field and the second term is the displacement due to the transverse velocity acquired in the magnetic field).

Thus using $\frac{1}{2} m_V v^2 = T$

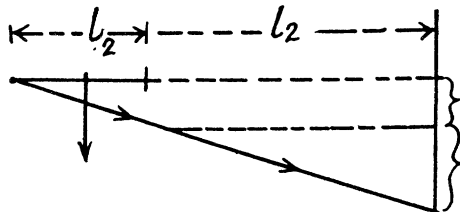

we get
$$\frac{\partial B}{\partial Z} = \frac{2 T \delta}{g \mu_B J l_1 (l_1 + 2 l_2)}$$

For vanadium atom in the ground state ${}^4F_{3/2}$.

$$g = 1 + \frac{\frac{3 \times 5}{4} + \frac{3 \times 5}{4} - 3 \times 4}{2 \times \frac{3 \times 5}{4}} = 1 + \frac{30 - 48}{30} = 1 - \frac{18}{30} = \frac{2}{5}$$

$J = \frac{3}{2}$, using other data, and substituting

we get
$$\frac{\partial B}{\partial Z} = 1.45 \times 10^{13} \text{ G/cm}$$

This value differs from the answer given in the book by almost a factor of 10^9 . For neutral atoms in stern Gerlach experiments, the value $T = 22 \text{ MeV}$ is much too large. A more appropriate value will be $T = 22 \text{ meV}$ i.e. 10^9 times smaller. Then one gets the right answer.

6.156 (a) The term $3P_0$ does not split in weak magnetic field as it has zero total angular momentum.

(b) The term ${}^2F_{5/2}$ will split into $2 \times \frac{5}{2} + 1 = 6$ sublevels. The shift in each sublevel is given by

$$\Delta E = -g \mu_B M_J B$$

where $M_J = -J(J-1), \dots, J$ and g is the Landi factor

$$g = 1 + \frac{\frac{5 \times 7}{4} + \frac{1 \times 3}{4} - 3 \times 4}{2 \times \frac{5 \times 7}{4}} = 1 + \frac{38 - 48}{70} = \frac{6}{7}$$

(c) In this case for the ${}^4D_{1/2}$ term

$$g = 1 + \frac{\frac{1 \times 3}{4} + \frac{3 \times 5}{4} - 2 \times 3}{2 \times \frac{1 \times 3}{4}} = 1 + \frac{3 + 15 - 24}{6} = 1 - 1 = 0$$

Thus the energy differences vanish and the level does not split.

6.157 (a) For the 1D_2 term

$$g = 1 + \frac{2 \times 3 + 0 - 2 \times 3}{2 \times 2 \times 3} = 1$$

and

$$\Delta E = -\mu_B M_J B$$

$M_J = -2, -1, 0, +1, +2$. Thus the splitting is

$$\delta E = 4 \mu_B B$$

Substitution gives $\delta E = 57.9 \mu \text{ eV}$

(b) For the 3F_4 term $g = 1 + \frac{4 \times 5 + 1 \times 2 - 3 \times 4}{2 \times 4 \times 5} = 1 + \frac{10}{40} = \frac{5}{4}$.

and $\Delta = -\frac{5}{4} \mu_B B M_J$

where $M_J = -4$ to $+4$. Thus

$$\delta E = \frac{5}{4} \mu_B B \times 8 = 10 \mu_B B (= 2 g J \mu_B)$$

Substitution gives $\delta E = 144.7 \mu \text{eV}$

6.158 (a) The term 1P_1 splits into 3 lines with $M_Z = \pm 1, 0$ in accordance with the formula

$$\Delta E = -g \mu_B B M_Z$$

where

$$g = 1 + \frac{1 \times 2 + 0 - 1 \times 2}{2 \times 1 \times 2} = 1$$

The term 1S_0 does not split in weak magnetic field. Thus the transitions between 1P_1 & 1S_0 will result in 3 lines i.e. a normal Zeeman triplet.

(b) The term ${}^2D_{5/2}$ will split into 6 terms in accordance with the formula

$$\Delta E = -g \mu_B M_Z$$

$$M_Z = \pm \frac{5}{2}, \pm \frac{3}{2}, \pm \frac{1}{2}, \text{ and}$$

$$g = 1 + \frac{5 \times 7 + 1 \times 3 - 4 \times 2 \times 3}{2 \times 5 \times 7} = \frac{6}{5}$$

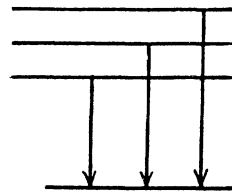

The term ${}^2P_{3/2}$ will also split into 4 lines in accordance with the above formula with

$$M_Z = \pm \frac{3}{2}, \pm \frac{1}{2} \text{ and } g = 1 + \frac{3 \times 5 + 1 \times 3 - 4 \times 1 \times 2}{2 \times 3 \times 5} = \frac{4}{3}$$

It is seen that the Zeeman splitting is anomalous as g factors are different.

(c) ${}^3D_1 \rightarrow {}^3P_0$

The term 3D_1 splits into 3 levels ($g = 5/2$)

The term 3P_0 does not split. Thus the Zeeman spectrum is normal.

(d) For the $5I_5$ term

$$\begin{aligned} g &= 1 + \frac{5 \times 6 + 2 \times 3 - 6 \times 7}{2 \times 5 \times 6} \\ &= 1 + \frac{36 - 42}{60} = 1 - \frac{1}{10} = \frac{9}{10} \end{aligned}$$

For the 5H_4 term

$$g = 1 + \frac{4 \times 5 + 2 \times 3 - 5 \times 6}{2 \times 4 \times 5} = 1 + \frac{26 - 30}{40} = \frac{9}{10}$$

We see that the splitting in the two levels given by $\Delta E = -g \mu_B B M_Z$ is the same though the number of levels is different (11 and 9). It is then easy to see that only the lines with following energies occur

$$\hbar \omega_0, \hbar \omega_0 \pm g \mu_B B.$$

The Zeeman pattern is normal

6.159 For a singlet term $S = 0$, $L = J$, $g = 1$

Then the total splitting is $\delta E = 2J \mu_B B$

Substitution gives $J = 3 (= \delta E / 2 \mu_B B)$

The term is 1F_3 .

6.160 As the spectral line is caused by transition between singlet terms, the Zeeman effect will be normal (since $g = 1$ for both terms). The energy difference between extreme components of the line will be $2 \mu_B B$. This must equal

$$-\Delta \left(\frac{2 \pi \hbar c}{\lambda} \right) = \frac{2 \pi \hbar c \Delta \lambda}{\lambda^2}$$

Thus

$$\Delta \lambda = \frac{\mu_B B \lambda^2}{\pi \hbar c} = 35 \text{ pm}.$$

6.161 From the previous problem, if the components are λ , $\lambda \pm \Delta \lambda$, then

$$\frac{\lambda}{\Delta \lambda} = \frac{2 \pi \hbar c}{\mu_B B \lambda}$$

For resolution $\frac{\lambda}{\Delta \lambda} \leq R = \frac{\lambda}{\delta \lambda}$ of the instrument.

Thus $\frac{2 \pi \hbar c}{\mu_B B \lambda} \leq R$ or $B \geq \frac{2 \pi \hbar c}{\mu_B \lambda R}$

Hence the minimum magnetic induction is

$$B_{\min} = \frac{2 \pi \hbar c}{\mu_B \lambda R} = 4 \text{ kG} = 0.4 \text{ T}$$

6.162 The 3P_0 term does not split. The 3D_1 term splits into 3 lines corresponding to the shift.

$$\Delta E = -g \mu_B B M_Z$$

with $M_Z = \pm 1, 0$. The interval between neighbouring components is then given by

$$\hbar \Delta \omega = g \mu_B B$$

Hence

$$B = \frac{\hbar \Delta \omega}{g \mu_B}$$

Now for the 3D_1 term

$$g = 1 + \frac{1 \times 2 + 1 \times 2 - 2 \times 3}{2 \times 1 \times 2} = 1 + \frac{4 - 6}{4} = \frac{1}{2}.$$

Substitution gives $B = 3.00 \text{ kG} = 0.3 \text{ T}$.

6.163 (a) For the ${}^2P_{3/2}$ term

$$g = 1 + \frac{\frac{3}{2} \times \frac{5}{2} + \frac{1}{2} \times \frac{3}{2} - 1 \times 2}{2 \times \frac{3}{2} \times \frac{5}{2}} = 1 + \frac{10}{30} = \frac{4}{3}$$

and the energy of the ${}^2P_{3/2}$ sublevels will be

$$E(M_Z) = E_0 - \frac{4}{3} \mu_B B M_Z$$

where $M_Z = \pm \frac{3}{2}, \pm \frac{1}{2}$. Thus, between neighbouring sublevels.

$$\delta E ({}^2P_{3/2}) = \frac{4}{3} \mu_B B$$

For the ${}^2P_{1/2}$ terms

$$\begin{aligned} g &= 1 + \frac{\frac{1}{2} \times \frac{3}{2} + \frac{1}{2} \times \frac{3}{2} - 1 \times 2}{2 \times \frac{1}{2} \times \frac{3}{2}} \\ &= 1 + \frac{6 - 8}{6} = 1 - \frac{1}{3} = \frac{2}{3} \end{aligned}$$

and the separation between the two sublevels into which the ${}^2P_{1/2}$ term will split is

$$\delta E ({}^2P_{1/2}) = \frac{2}{3} \mu_B B$$

The ratio of the two splittings is 2 : 1.

(b) The interval between neighbouring Zeeman sublevels of the ${}^2P_{3/2}$ term is $\frac{4}{3} \mu_B B$. The

energy separation between D_1 and D_2 lines is $\frac{2\pi\hbar c}{\lambda^2} \Delta\lambda$ (this is the natural separation of the 2P them)

Thus
$$\frac{4}{3} \mu_B B = \frac{2\pi\hbar c \Delta\lambda}{\lambda^2 \eta}$$

or
$$B = \frac{3\pi\hbar c \Delta\lambda}{2\mu_B \lambda^2 \eta}$$

Substitution gives

$$B = 5.46 \text{ kG}$$

6.164 For the ${}^2P_{3/2}$ level $g = 4/3$ (see above) and the energies of sublevels are

$$E' = E'_0 - \frac{4}{3} \mu_B B M'_z$$

where $M'_z = \pm \frac{3}{2}, \pm \frac{1}{2}$ for the four sublevels

For the ${}^2S_{1/2}$ level, $g = 2$ (since $L = 0$) and

$$E = E_0 - 2 \mu_B B M_z$$

where

$$M_z = \pm \frac{1}{2}$$

Permitted transitions must have

$$\Delta M_z = 0, \pm 1$$

Thus only the following transitions occur

$$\left. \begin{array}{l} \frac{3}{2} \rightarrow \frac{1}{2} \\ -3/2 \rightarrow -1/2 \end{array} \right\} \Delta \omega = \pm \mu_B B / \hbar = 3.96 \times 10^{10} \text{ rad/s}$$

$$\left. \begin{array}{l} \frac{1}{2} \rightarrow \frac{1}{2} \\ -\frac{1}{2} \rightarrow -\frac{1}{2} \end{array} \right\} \Delta \omega = \pm \frac{1}{3} \mu_B B / \hbar = 1.32 \times 10^{10} \text{ rad/s}$$

$$\left. \begin{array}{l} \frac{1}{2} \rightarrow -\frac{1}{2} \\ -\frac{1}{2} \rightarrow \frac{1}{2} \end{array} \right\} \Delta \omega = \pm \frac{5}{3} \frac{\mu_B B}{\hbar} = 6.6 \times 10^{10} \text{ rad/s}$$

These six lines are shown below

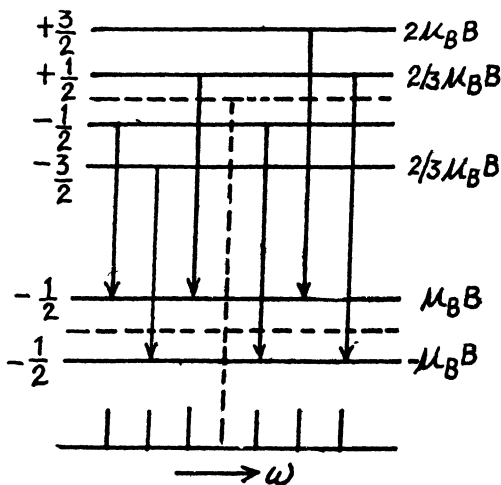

6.165 The difference arises because of different selection rules in the two cases. In (1) the line is emitted perpendicular to the field. The selection rules are then

$$\Delta M_z = 0, \pm 1$$

In (2) the light is emitted along the direction of the field. Then the selection rules are

$$\Delta M_z = \pm 1$$

$$\Delta M_z = 0 \text{ is forbidden.}$$

(a) In the transition ${}^2P_{3/2} \rightarrow {}^2S_{1/2}$

This has been considered above. In (1) we get all the six lines shown in the problem above

In (2) the line corresponding to $\frac{1}{2} \rightarrow \frac{1}{2}$ and $-\frac{1}{2} \rightarrow -\frac{1}{2}$ is forbidden.

Then we get four lines

(b) ${}^3P_2 \rightarrow {}^3S_1$

$$\text{For the } {}^3P_2 \text{ level, } g = 1 + \frac{2 \times 3 + 1 \times 2 - 1 \times 2}{2 \times 2 \times 3} = \frac{3}{2}$$

so the energies of the sublevels are

$$E'(M'_z) = E'_0 - \frac{3}{2} \mu_B B M'_z$$

where

$$M'_z = \pm 2, \pm 1, 0$$

For the 3S_1 line, $g = 2$ and the energies of the sublevels are

$$E(M_z) = E_0 - 2 \mu_B B M_z$$

where

$$M_z = \pm 1, 0. \text{ The lines are}$$

$$\Delta M_z = M_z - M'_z = +1 \quad : \quad -2 \rightarrow -1, -1 \rightarrow 0 \text{ and } 0 \rightarrow 1$$

$$\Delta M_z = 0 \quad -1 \rightarrow -1, 0 \rightarrow 0, 1 \rightarrow 1$$

$$\Delta M_z = 1, 2 \rightarrow 1, 1 \rightarrow 0, 0 \rightarrow -1$$

All energy differences are unequal because the two g values are unequal. There are then nine lines if viewed along (1) and six lines if viewed along (2).

6.166 For the two levels

$$E'_0 = E_0 - g' \mu'_B M'_z B$$

$$E_0 = E_0 - g \mu_B M_z B$$

and hence the shift of the component is the value of

$$\Delta \omega = \frac{\mu_B B}{\hbar} [g' M'_z - g M_z]$$

subject to the selection rule $\Delta M_z = 0, \pm 1$. For 3D_3

$$g' = 1 + \frac{3 \times 4 + 1 \times 2 - 2 \times 3}{2 \times 3 \times 4} = 1 + \frac{8}{24} = \frac{4}{3}$$

For 3P_2 ,

$$g = 1 + \frac{2 \times 3 + 1 \times 2 - 1 \times 2}{2 \times 2 \times 3} = \frac{3}{2}$$

Thus
$$\Delta \omega = \frac{\mu_B B}{\hbar} \left| \frac{4}{3} M'_z - \frac{3}{2} M_z \right|$$

For the different transition we have the following table

		$M'_z g' - M_z g$		
3 → 2	$\mu_B B$	0 → 1	$-\frac{3}{2} \mu_B B$	
2 → 2	$-\frac{1}{3} \mu_B B$	0 → 0	0	
2 → 1	$7/6 \mu_B B$	0 → -1	$3/2 \mu_B B$	
1 → 2	$-5/3 \mu_B B$	-1 → 0	$-4/3 \mu_B B$	
1 → 1	$-1/6 \mu_B B$	-1 → -1	$1/6 \mu_B B$	
1 → 0	$4/3 \mu_B B$	-1 → -2 →	$5/3 \mu_B B$	
		-2 → -1 →	$-7/6 \mu_B B$	
		-2 → -2 →	$1/3 \mu_B B$	
		-3 → -2 →	$-\mu_B B$	

There are 15 lines in all.

The lines farthest out are $1 \rightarrow 2$ and $-1 \rightarrow -2$.

The splitting between them is the total splitting. It is

$$\Delta \omega = \frac{10}{3} \mu_B B / \hbar$$

Substitution gives $\Delta \omega = 7.8 \times 10^{10}$ rad/sec.

6.4 MOLECULES AND CRYSTALS

6.167 In the first excited rotational level $J = 1$

so
$$E_J = 1 \times 2 \frac{\hbar^2}{2I} = \frac{1}{2} I \omega^2 \text{ classically}$$

Thus
$$\omega = \sqrt{2} \frac{\hbar}{I}$$

Now
$$I = \Sigma m_i r_i^2 = \frac{m}{2} \frac{d^2}{4} + \frac{m}{2} \frac{d^2}{4} = m \frac{d^2}{4}$$

where m is the mass of the mole cub and r_i is the distance of the atom from the axis.

Thus
$$\omega = \frac{4\sqrt{2}\hbar}{m d^2} = 1.56 \times 10^{11} \text{ rad/s}$$

6.168 The axis of rotation passes through the centre of mass of the HCl molecule. The distances of the two atoms from the centre of mass are

$$d_H = \frac{m_{Cl}}{m_{HCl}} d, \quad d_{Cl} = \frac{m_H}{m_{HCl}} d$$

Thus $I =$ moment of inertia about the axis

$$= \frac{4}{2} m_H d_H^2 + m_{Cl} d_{Cl}^2 = \frac{m_H m_{Cl}}{m_H + m_{Cl}} d^2$$

The energy difference between two neighbouring levels whose quantum numbers are J & $J - 1$ is

$$\frac{\hbar^2}{2I} \cdot 2J = \frac{J\hbar^2}{I} = 7.86 \text{ meV}$$

Hence $J = 3$ and the levels have quantum numbers 2 & 3.

6.169 The angular momentum is $\sqrt{2IE} = M$

Now
$$I = \frac{m d^2}{4} \quad (m = \text{mass of } O_2 \text{ molecule}) = 1.9584 \times 10^{-39} \text{ gm c}^2$$

So
$$M = 3.68 \times 10^{-27} \text{ erg sec.} = 3.49\hbar$$

(This corresponds to $J = 3$)

6.170 From $E_J = \frac{\hbar^2}{2I} J(J+1)$

and the selection rule $\Delta J = 1$ or $J \rightarrow J - 1$ for a pure rotational spectrum we get

$$\omega(J, J-1) = \frac{\hbar J}{I}$$

Thus transition lines are equispaced in frequency $\Delta \omega = \frac{\hbar}{I}$.

In the case of CH molecule

$$I = \frac{\hbar}{\Delta \omega} = 1.93 \times 10^{-40} \text{ gm cm}^2$$

Also

$$I = \frac{m_c m_H}{m_c + m_H} d^2$$

so

$$d = 1.117 \times 10^{-8} \text{ cm} = 111.7 \text{ pm}$$

- 6.171** If the vibrational frequency is ω_0 the excitation energy of the first vibrational level will be $\hbar \omega_0$. Thus if there are J rotational levels contained in the band between the ground state and the first vibrational excitation, then

$$\hbar \omega_0 = \frac{J(J+1)\hbar^2}{2I}$$

where as stated in the problem we have ignored any coupling between the two. For HF molecule

$$I = \frac{m_H m_F}{m_H + m_F} d^2 = 1.336 \times 10^{-4} \text{ gm cm}^2$$

Then

$$J(J+1) = \frac{2I\omega_0}{\hbar} = 197.4$$

For $J = 14$, $J(J+1) = 210$. For $J = 13$, $J(J+1) = 182$. Thus there lie 13 levels between the ground state and the first vibrational excitation.

- 6.172** We proceed as above. Calculating $\frac{2I\omega_0}{\hbar}$ we get

$$\frac{2I\omega_0}{\hbar} = 1118$$

Now this must equal $J(J+1) = \left(J + \frac{1}{2}\right)^2$

Taking the square root we get $J = 33$.

- 6.173** From the formula

$$J(J+1) \frac{\hbar^2}{2I} = E \text{ we get } J(J+1) = 2IE/\hbar^2$$

or

$$\left(J + \frac{1}{2}\right)^2 - \frac{1}{4} = \frac{2IE}{\hbar^2}$$

Hence

$$J = -\frac{1}{2} + \sqrt{\frac{1}{4} + \frac{2IE}{\hbar^2}}$$

writing

$$J+1 = -\frac{1}{2} + \sqrt{\frac{1}{4} + \frac{2I}{\hbar^2}(E + \Delta E)}$$

we find

$$\begin{aligned}
 1 &= \sqrt{\frac{1}{4} + \frac{2I}{\hbar^2}E + \frac{2I}{\hbar^2}\Delta E} - \sqrt{\frac{1}{4} + \frac{2IE}{\hbar^2}} \\
 &= \sqrt{\frac{1}{4} + \frac{2I}{\hbar^2}E} \left[\left(1 + \frac{\Delta E}{E + \frac{\hbar^2}{8I}} \right)^{1/2} - 1 \right] \\
 &= \sqrt{\frac{1}{4} + \frac{2I}{\hbar^2}E} \cdot \frac{\Delta E}{2 \left(E + \frac{\hbar^2}{8I} \right)} \\
 &= \sqrt{\frac{2I}{\hbar^2}} \frac{\Delta E}{2 \sqrt{E + \frac{\hbar^2}{8I}}}
 \end{aligned}$$

The quantity $\frac{dN}{dE}$ is $\frac{1}{\Delta E}$. For large E it is

$$\frac{dN}{dE} = \sqrt{\frac{I}{2\hbar^2 E}}$$

For an iodine molecule

$$I = m_1 d^2 / 2 = 7.57 \times 10^{-38} \text{ gm cm}^2$$

Thus for $J = 10$

$$\frac{dN}{dE} = \sqrt{\frac{I}{2\hbar^2 \cdot \frac{\hbar^2}{2I} J(J+1)}} = \frac{I}{\sqrt{J(J+1)} \hbar^2}$$

Substitution gives

$$\frac{dN}{dE} = 1.04 \times 10^4 \text{ levels per eV}$$

6.174 For the first rotational level

$$E_{rot} = 2 \frac{\hbar^2}{2I} = \frac{\hbar^2}{I} \text{ and}$$

for the first vibrational level $E_{vib} = \hbar \omega$

$$\text{Thus } \xi = \frac{E_{vib}}{E_{rot}} = \frac{I \omega}{\hbar}$$

Here ω = frequency of vibration. Now

$$I = \mu d^2 = \frac{m_1 m_2}{m_1 + m_2} d^2.$$

(a) For H_2 molecule $I = 4.58 \times 10^{-41} \text{ gm cm}^2$ and $\xi = 36$

(b) For HI molecule,

$$I = 4.247 \times 10^{-40} \text{ gm cm}^2 \text{ and } \xi = 175$$

(c) For I_2 molecule

$$I = 7.57 \times 10^{-38} \text{ gm cm}^2 \text{ and } \xi = 2872$$

6.175 The energy of the molecule in the first rotational level will be $\frac{\hbar^2}{I}$. The ratio of the number of molecules at the first excited vibrational level to the number of molecules at the first excited rotational level is

$$\frac{e^{-\hbar\omega/kT}}{(2J+1)e^{-\hbar^2 J(J+1)/2IkT}}$$

$$= \frac{1}{3} e^{-\hbar\omega/kT} \times e^{-\hbar^2/IkT} = \frac{1}{3} e^{-\hbar(\omega - 2B)/kT}$$

where

$$B = \hbar^2/2I$$

For the hydrogen molecule $I = \frac{1}{2} m_H d^2$

$$= 4.58 \times 10^{-41} \text{ gm cm}^2$$

Substitution gives 3.04×10^{-4}

6.176 By definition

$$\langle E \rangle = \frac{\sum E_\nu e^{-E_\nu/kT}}{\sum \exp(-E_\nu/kT)} = \frac{\frac{\partial}{\partial \beta} \sum_{\nu=0}^{\infty} e^{-\beta E_\nu}}{\sum_{\nu=0}^{\infty} e^{-\beta E_\nu}}$$

$$= -\frac{\partial}{\partial \beta} \ln \sum_{\nu=0}^{\infty} e^{-\beta(\nu+1/2)\hbar\omega}, \quad \beta = \frac{1}{kT}$$

$$= -\frac{\partial}{\partial \beta} \ln e^{-1/2\beta\hbar\omega} \frac{1}{1 - e^{-\beta\hbar\omega}}$$

$$= -\frac{\partial}{\partial \beta} \left[-\frac{1}{2}\hbar\omega\beta - \ln(1 - e^{-\beta\hbar\omega}) \right]$$

$$= \frac{1}{2}\hbar\omega + \frac{\hbar\omega}{e^{\hbar\omega/kT} - 1}$$

Thus for one gm mole of diatomic gas

$$C_{V_{1,vib}} = N \frac{\partial \langle E \rangle}{\partial T} = \frac{R \left(\frac{\hbar \omega}{kT} \right)^2 e^{\hbar \omega / kT}}{\left(e^{\hbar \omega / kT} - 1 \right)^2}$$

where $R = Nk$ is the gas constant.

In the present case

$$\frac{\hbar \omega}{kT} = 2.7088$$

and

$$C_{V_{1,vib}} = 0.56 R$$

6.177 In the rotation vibration band the main transition is due to change in vibrational quantum number $\nu \rightarrow \nu - 1$. Together with this rotational quantum number may change. The "Zeroeth line" $0 \rightarrow 0$ is forbidden in this case so the neighbouring lines arise due to $1 \rightarrow 0$ or $0 \rightarrow 1$ in the rotational quantum number. Now

$$E = E_\nu + \frac{\hbar^2}{2I} J(J+1)$$

Thus

$$\hbar \omega = \hbar \omega_0 + \frac{\hbar^2}{2I} (\pm 2)$$

Hence

$$\Delta \omega = \frac{2\hbar}{I} = \frac{2\hbar}{\mu d^2}$$

so

$$d = \sqrt{\frac{2\hbar}{\mu \Delta \omega}}$$

Substitution gives $d = 0.128 \text{ nm}$.

6.178 If $\lambda_R =$ wavelength of the red satellite
and $\lambda_V =$ wavelength of the violet satellite

then

$$\frac{2\pi\hbar c}{\lambda_R} = \frac{2\pi\hbar c}{\lambda_0} - \hbar \omega$$

and

$$\frac{2\pi\hbar c}{\lambda_V} = \frac{2\pi\hbar c}{\lambda_0} + \hbar \omega$$

Substitution gives

$$\lambda_R = 424.3 \text{ nm}$$

$$\lambda_V = 386.8 \text{ nm}$$

The two formulas can be combined to give

$$\lambda = \frac{2\pi c}{\frac{2\pi c}{\lambda_0} + \omega} = \frac{\lambda_0}{1 + \frac{\lambda_0 \omega}{2\pi c}}$$

6.179 As in the previous problem

$$\omega = \pi c \left(\frac{1}{\lambda_V} - \frac{1}{\lambda_R} \right) = \frac{\pi c (\lambda_R - \lambda_V)}{\lambda_R \lambda_V} = 1.368 \times 10^{14} \text{ rad/s}$$

The force constant x is defined by

$$x = \mu \omega^2$$

where μ = reduced mass of the S_2 molecule.

Substitution gives

$$x = 5.01 \text{ N/cm}$$

6.180 The violet satellite arises from the transition $1 \rightarrow 0$ in the vibrational state of the scattering molecule while the red satellite arises from the transition $0 \rightarrow 1$. The intensities of these two transitions are in the ratio of initial populations of the two states i.e. in the ratio

$$e^{-\hbar \omega / kT}$$

Thus

$$\frac{I_v}{I_r} = e^{-\hbar \omega / kT} = 0.067$$

If the temperature is doubled, the ratio increases to 0.259, an increase of 3.9 times.

6.181 (a) CO_2 (O - C - O)

The molecule has 9 degrees of freedom 3 for each atom. This means that it can have up to nine frequencies. 3 degrees of freedom correspond to rigid translation, the frequency associated with this is zero as the potential energy of the system can not change under rigid translation. The P.E. will not change under rotations about axes passing through the C-atom and perpendicular to the O - C - O line. Thus there can be at most four non zero frequencies. We must look for modes different from the above.

One mode is



Another mode is



These are the only collinear modes.

A third mode is doubly degenerate :

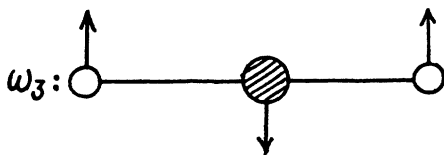

(vibration in & \perp to the plane of paper).

(b) C_2H_2 (H - C - C - H)

There are $4 \times 3 - 3 - 2 = 7$ different vibrations. There are three collinear modes.

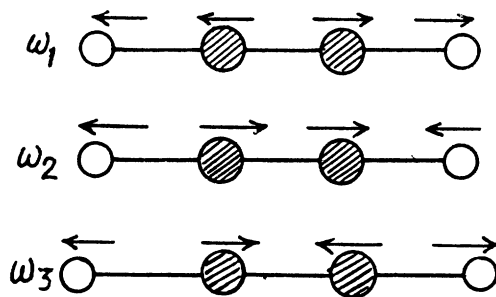

Two other doubly degenerate frequencies are

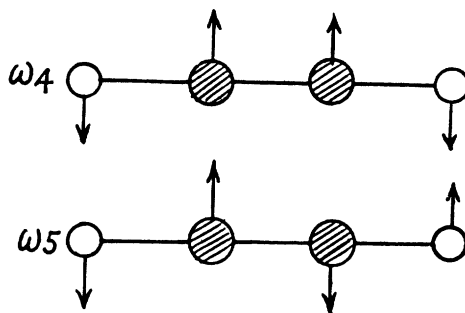

together with their counterparts in the plane \perp to the paper.

6.182 Suppose the string is stretched along the x axis from $x = 0$ to $x = l$ with the end points fixed. Suppose $y(x, t)$ is the transverse displacement of the element at x at time t . Then $y(x, t)$ obeys

$$\frac{\partial^2 y}{\partial t^2} = v^2 \frac{\partial^2 y}{\partial x^2}$$

We look for a stationary wave solution of this equation

$$y(x, t) = A \sin \frac{\omega}{v} x \sin(\omega t + \delta)$$

where A & δ are constants. In this from $y = 0$ at $x = 0$. The further condition

$$y = 0 \quad \text{at} \quad x = l$$

implies

$$\frac{\omega l}{v} = N\pi, \quad N > 0$$

or

$$N = \frac{l}{\pi v} \omega$$

N is the number of modes of frequency $\leq \omega$.

Thus

$$dN = \frac{l}{\pi v} d\omega$$

6.183 Let $\xi(x, y, t)$ be the displacement of the element at (x, y) at time t . Then it obeys the equation

$$\frac{\partial^2 \xi}{\partial t^2} = v^2 \left(\frac{\partial^2 \xi}{\partial x^2} + \frac{\partial^2 \xi}{\partial y^2} \right)$$

where $\xi = 0$ at $x = 0, x = l, y = 0$ and $y = l$.

We look for a solution in the form

$$\xi = A \sin k_1 x \sin k_2 y \sin(\omega t + \delta)$$

Then

$$\omega^2 = v^2 (k_1^2 + k_2^2)$$

$$k_1 = \frac{n\pi}{l}, k_2 = \frac{m\pi}{l}$$

we write this as

$$n^2 + m^2 = \left(\frac{l\omega}{\pi v} \right)^2$$

Here $n, m > 0$. Each pair (n, m) determines a mode. The total number of modes whose frequency is $\leq \omega$ is the area of the quadrant of a circle of radius $\frac{l\omega}{\pi v}$ i.e.

$$N = \frac{\pi}{4} \left(\frac{l\omega}{\pi v} \right)^2$$

Then

$$dN = \frac{l^2}{2\pi v^2} \omega d\omega = \frac{S}{2\pi v^2} \omega d\omega.$$

where $S = l^2$ is the area of the membrane.

6.184 For transverse vibrations of a 3-dimensional continuum (in the form of a cube say) we have the equation

$$\frac{\partial^2 \vec{\xi}}{\partial t^2} = v^2 \nabla^2 \vec{\xi}, \quad \text{div } \vec{\xi} = 0$$

Here $\vec{\xi} = \vec{\xi}(x, y, z, t)$. We look for solutions in the form

$$\vec{\xi} = \vec{A} \sin k_1 x, \sin k_2 y, \sin k_3 z, \sin(\omega t + \delta)$$

This requires $\omega^2 = v^2 (k_1^2 + k_2^2 + k_3^2)$

From the boundary condition that $\vec{\xi} = 0$ for $x = 0, x = l, y = 0, y = l, z = 0, z = l$, we get

$$k_1 = \frac{n_1 \pi}{l}, k_2 = \frac{n_2 \pi}{l}, k_3 = \frac{n_3 \pi}{l}$$

where n_1, n_2, n_3 are nonzero positive integers.

We then get

$$n_1^2 + n_2^2 + n_3^2 = \left(\frac{l\omega}{\pi v} \right)^2$$

Each triplet (n_1, n_2, n_3) determines a possible mode and the number of such modes whose frequency $\leq \omega$ is the volume of the all positive octant of a sphere of radius $\frac{l\omega}{\pi v}$. Considering also the fact that the subsidiary condition $\text{div } \vec{\xi} = 0$ implies two independent values of \vec{A} for each choice of the wave vector (k_1, k_2, k_3)

we find

$$N(\omega) = \frac{1}{8} \cdot \frac{4\pi}{3} \left(\frac{l\omega}{\pi v} \right)^3 \cdot 2 = \frac{V\omega^3}{3\pi^2 v^3}$$

Thus

$$dN = \frac{V\omega^2}{\pi^2 v^3} d\omega.$$

6.185 To determine the Debye temperature we cut off the high frequency modes in such a way as to get the total number of modes correctly.

(a) In a linear crystal with $n_0 l$ atoms, the number of modes of transverse vibrations in any given plane cannot exceed $n_0 l$. Then

$$n_0 l = \frac{l}{\pi v} \int_0^{\omega_0} d\omega = \frac{l}{\pi v} \omega_0$$

The cut off frequency ω_0 is related to the Debye temperature Θ by

$$\hbar \omega_0 = k \Theta$$

Thus

$$\Theta = \left(\frac{\hbar}{k} \right) \pi n_0 v$$

(b) In a square lattice, the number of modes of transverse oscillations cannot exceed $n_0 S$.

Thus

$$n_0 S = \frac{S}{2\pi v^2} \int_0^{\omega_0} \omega d\omega = \frac{S}{4\pi v^2} \omega_0^2$$

or

$$\Theta = \frac{\hbar}{k} \omega_0 = \left(\frac{\hbar}{k} \right) (\sqrt{4\pi n_0}) v$$

(c) In a cubic crystal, the maximum number of transverse waves must be $2 n_0 V$ (two for each atom). Thus

$$2 n_0 V = \frac{V}{\pi^2 v^3} \int_0^{\omega_0} \omega^2 d\omega = \frac{V\omega_0^3}{3\pi^2 v^3}.$$

Thus

$$\Theta = \left(\frac{\hbar}{k} \right) v (6\pi^2 n_0)^{1/3}.$$

6.186 We proceed as in the previous example. The total number of modes must be $3 n_0 v$ (total transverse and one longitudinal per atom). On the other hand the number of transverse modes per unit frequency interval is given by

$$dN^\perp = \frac{V \omega^2}{\pi^2 v_\perp^3} d\omega$$

while the number of longitudinal modes per unit frequency interval is given by

$$dN^\parallel = \frac{V \omega^2}{2 \pi^2 v_\parallel^3} d\omega$$

The total number per unit frequency interval is

$$dN = \frac{V \omega^2}{2 \pi^2} \left(\frac{2}{v_\perp^3} + \frac{1}{v_\parallel^3} \right) d\omega$$

If the high frequency cut off is at $\omega_0 = \frac{k \Theta}{\hbar}$, the total number of modes will be

$$3 n_0 V = \frac{V}{6 \pi^2} \left(\frac{2}{v_\perp^3} + \frac{1}{v_\parallel^3} \right) \left(\frac{k \Theta}{\hbar} \right)^3$$

Here n_0 is the number of iron atoms per unit volume. Thus

$$\Theta = \frac{\hbar}{k} \left[18 \pi^2 n_0 / \left(\frac{2}{v_\perp^3} + \frac{1}{v_\parallel^3} \right) \right]^{1/3}$$

For iron

$$n_0 = N_A / \frac{M}{\rho} = \frac{\rho N_A}{M}$$

(ρ = density, M = atomic weight of iron N_A = Avogadro number).

$$n_0 = 8.389 \times 10^{22} \text{ per cc}$$

Substituting the data we get

$$\Theta = 469.1 \text{ K}$$

6.187 We apply the same formula but assume $v_\parallel \approx v_\perp$. Then

$$\Theta = \frac{\hbar}{k} v (6 \pi^2 n_0)^{1/3}$$

or

$$v = k \Theta / \left[\hbar (6 \pi^2 n_0)^{1/3} \right]$$

For Al

$$n_0 = \frac{\rho N_A}{M} = 6.023 \times 10^{22} \text{ per c.c.}$$

Thus

$$v = 3.39 \text{ km/s.}$$

The tabulated values are $v_{\parallel} = 6.3 \text{ km/s}$

and

$$v_{\perp} = 3.1 \text{ km/s.}$$

6.188 In the Debye approximation the number of modes per unit frequency interval is given by

$$dN = \frac{l}{\pi v} d\omega \quad 0 \leq \omega \leq \frac{k\Theta}{\hbar}$$

But

$$\frac{k\Theta}{\hbar} = \pi n_0 v$$

Thus

$$dN = \frac{l}{\pi v} d\omega, \quad 0 \leq \omega \leq \pi n_0 v$$

The energy per mode is

$$\langle E \rangle = \frac{1}{2} \hbar \omega + \frac{\hbar \omega}{e^{\hbar \omega / kT} - 1}$$

Then the total interval energy of the chain is

$$U = \frac{l}{\pi v} \int_0^{\pi n_0 v} \frac{1}{2} \hbar \omega d\omega$$

$$+ \frac{l}{\pi v} \int_0^{\pi n_0 v} \frac{\hbar \omega}{e^{\hbar \omega / kT} - 1} d\omega = \frac{l \hbar}{4 \pi v} (\pi n_0 v)^2 + \frac{l}{\pi v \hbar} (kT)^2 \int_0^{\Theta/T} \frac{x dx}{e^x - 1} = l n_0 k \cdot \frac{\hbar}{k} (\pi n_0 v) \cdot \frac{1}{4}$$

$$+ l n_0 k \frac{T^2}{(\pi n_0 v \hbar / k)} \int_0^{\Theta/T} \frac{x dx}{e^x - 1}$$

We put $l n_0 k = R$ for 1 mole of the chain.

Then

$$U = R \Theta \left\{ \frac{1}{4} + \left(\frac{T}{\Theta} \right)^2 \int_0^{\Theta/T} \frac{x dx}{e^x - 1} \right\}$$

Hence the molar heat capacity is by differentiation

$$C_V = \left(\frac{\partial U}{\partial T} \right)_{\Theta} = R \left[2 \left(\frac{T}{\Theta} \right) \int_0^{\Theta/T} \frac{x dx}{e^x - 1} - \frac{\Theta/T}{e^{\Theta/T} - 1} \right]$$

when

$$T \gg \Theta, \quad C_V \approx R.$$

6.189 If the chain has N atoms, we can assume atom number 0 and $N + 1$ held fixed. Then the displacement of the n^{th} atom has the form

$$u_n = A \left(\sin \frac{m\pi}{L} \cdot n a \right) \sin \omega t$$

Here $k = \frac{m\pi}{L}$. Allowed frequencies then have the form

$$\omega = \omega_{\max} \sin \frac{k a}{2}$$

In our form only +ve k values are allowed.

The number of modes in a wave number range dk is

$$dN = \frac{L dk}{\pi} = \frac{L}{\pi} \frac{dk}{d\omega} d\omega$$

But

$$d\omega = \frac{a}{2} \omega_{\max} \cos \frac{k a}{2} dk$$

Hence

$$\frac{d\omega}{dk} = \frac{a}{2} \sqrt{\omega_{\max}^2 - \omega^2}$$

So

$$dN = \frac{2L}{\pi a} \frac{d\omega}{\sqrt{\omega_{\max}^2 - \omega^2}}$$

(b) The total number of modes is

$$N = \int_0^{\omega_{\max}} \frac{2L}{\pi a} \frac{d\omega}{\sqrt{\omega_{\max}^2 - \omega^2}} = \frac{2L}{\pi a} \cdot \frac{\pi}{2} = \frac{L}{a}$$

i.e. the number of atoms in the chain.

6.190 Molar zero point energy is $\frac{9}{8}R\Theta$. The zero point energy per gm of copper is $\frac{9R\Theta}{8M_{Cu}}$, M_{Cu} is the atomic weight of the copper. Substitution gives 48.6 J/gm.

6.191 (a) By Dulong and Petit's law, the classical heat capacity is $3R = 24.94 \text{ J/K - mole}$. Thus

$$\frac{C}{C_{cl}} = 0.6014$$

From the graph we see that this

value of $\frac{C}{C_{cl}}$ corresponds to $\frac{T}{\Theta} = 0.29$

Hence

$$\Theta = \frac{65}{0.29} \approx 224 \text{ K}$$

(b) 22.4 J/mole-K corresponds to $\frac{22.4}{3 \times 8.314} = 0.898$. From the graph this corresponds to

$$\frac{T}{\Theta} \approx 0.65. \text{ This gives } \Theta = \frac{250}{0.65} \approx 385 \text{ K}$$

Then 80 K corresponds to $\frac{T}{\Theta} = 0.208$

The corresponding value of $\frac{C}{C_{cl}}$ is 0.42 . Hence $C = 10.5 \text{ J/mole-K}$.

(c) We calculate Θ from the datum that $\frac{C}{C_{cl}} = 0.75$ at $T = 125 \text{ K}$.

The x -coordinate corresponding to 0.75 is 0.40 . Hence

$$\Theta = \frac{125}{0.4} = 3125 \text{ K}$$

Now

$$k\Theta = \hbar \omega_{\max}$$

So

$$\omega_{\max} = 4.09 \times 10^{13} \text{ rad/sec}$$

6.192 We use the formula (6.4d)

$$U = 9R\Theta \left[\frac{1}{8} + \left(\frac{T}{\Theta}\right)^4 \int_0^{\Theta/T} \frac{x^3 dx}{e^x - 1} \right]$$

$$= 9R\Theta \left[\frac{1}{8} + \left\{ \int_0^{\infty} \frac{x^3 dx}{e^x - 1} \right\} \left(\frac{T}{\Theta}\right)^4 - \left(\frac{T}{\Theta}\right)^4 \int_{\Theta/T}^{\infty} \frac{x^3 dx}{e^x - 1} \right]$$

In the limit $T \ll \Theta$, the third term in the bracket is exponentially small together with its derivatives.

Then we can drop the last term

$$U = \text{Const} + \frac{9R}{\Theta^3} T^4 \int_0^{\infty} \frac{x^3 dx}{e^x - 1}$$

Thus

$$C_V = \left(\frac{\partial U}{\partial T}\right)_V = \left(\frac{\partial U}{\partial T}\right)_{\Theta} = 36R \left(\frac{T}{\Theta}\right)^3 \int_0^{\infty} \frac{x^3 dx}{e^x - 1}$$

Now from the table in the book

$$\int_0^{\infty} \frac{x^3 dx}{e^x - 1} = \frac{\pi^4}{15}.$$

Thus

$$C_V = \frac{12\pi^4}{5} \left(\frac{T}{\Theta}\right)^3$$

Note :- Call the 3rd term in the bracket above - U_3 . Then

$$U_3 = \left(\frac{T}{\Theta}\right)^4 \int_{\Theta/T}^{\infty} \frac{x^3}{2 \sin h(x/2)} \cdot e^{-x/2} dx$$

The maximum value of $\frac{x^3}{2 \sin h \frac{x}{2}}$ is a finite +ve quantity C_0 for $0 \leq x < \infty$. Thus

$$U_3 \leq 2 C_0 \left(\frac{T}{\Theta}\right)^4 e^{-\Theta/2T}$$

we see that U_3 is exponentially small as $T \rightarrow 0$. So is $\frac{dU_3}{dT}$.

6.193 At low temperatures $C \propto T^3$. This is also a test of the "lowness" of the temperature. We see that

$$\left(\frac{C_1}{C_2}\right)^{1/3} = 1.4982 \approx 1.5 = \frac{T_1}{T_2} = \frac{30}{20}$$

Thus T^3 law is obeyed and T_1, T_2 can be regarded low.

6.194

The total zero point energy of 1 mole of the solid is $\frac{9}{8} R \Theta$. Dividing this by the number of modes $3N$ we get the average zero point energy per mode. It is

$$\frac{3}{8} k \Theta.$$

6.195 In the Debye model

$$dN_{\omega} = A \omega^2, \quad 0 \leq \omega \leq \omega_m$$

Then
$$3N = \int_0^{\omega_m} dN_{\omega} = \frac{A \omega_m^3}{3}. \quad (\text{Total no. of modes is } 3N)$$

Thus
$$A = \frac{9N}{\omega_m^3}.$$

we get

$$\begin{aligned}
 U &= \frac{9N}{\omega_m^3} \int_0^{\omega_m} \frac{\omega^2 \cdot \hbar \omega}{e^{\hbar \omega/kT} - 1} d\omega \quad \text{ignoring zero point energy} \\
 &= 9N\hbar \omega_m \int_0^1 \frac{x^3 dx}{e^{\hbar \omega_m x/kT} - 1}, \quad x = \frac{\omega}{\omega_m} \\
 &= 9R\Theta \int_0^1 \frac{x^3 dx}{e^{x\Theta/T} - 1}, \quad \Theta = \hbar \omega_m/k
 \end{aligned}$$

Thus
$$\frac{1}{9R\Theta} \frac{dU(x)}{dx} = \frac{x^3}{e^{x\Theta/T} - 1} \quad \text{for } 0 \leq x \leq 1$$

For
$$T = \Theta/2, \quad \text{this is } \frac{x^3}{e^{2x} - 1}; \quad \text{for}$$

$$T = \frac{\Theta}{4}, \quad \text{it is } \frac{x^3}{e^{4x} - 1}.$$
 Plotting then we get the figures given in the answer.

6.196 The maximum energy of the phonon is

$$\hbar \omega_m = k\Theta = 28.4 \text{ meV}$$

On substituting $\Theta = 330 \text{ K}$.

To get the corresponding value of the maximum momentum we must know the dispersion relation $\omega = \omega(\vec{k})$. For small (\vec{k}) we know $\omega = v|\vec{k}|$ where v is velocity of sound in the crystal. For an order of magnitude estimate we continue to use this result for high $|\vec{k}|$. Then we estimate v from the values of the modulus of elasticity and density

$$v \sim \sqrt{\frac{E}{\rho}}$$

We write
$$E \sim 100 \text{ GPa}, \quad \rho = 8.9 \times 10^3 \text{ kg/m}^3$$

Then
$$v \sim 3 \times 10^3 \text{ m/s}$$

Hence
$$\hbar |\vec{k}|_{\text{max}} \sim \frac{\hbar \omega_m}{v} \sim 1.5 \times 10^{-19} \text{ gm cm s}^{-1}$$

6.197 (a) From the formula

$$dn = \frac{\sqrt{2} m^{3/2}}{\pi^2 \hbar^3} E^{1/2} dE$$

the maximum value E_{max} of E is determined in terms of n by

$$n = \frac{\sqrt{2} m^{3/2}}{\pi^2 \hbar^3} \int_0^{E_{\max}} E^{1/2} dE$$

$$= \frac{\sqrt{2} m^{3/2}}{\pi^2 \hbar^3} \frac{2}{3} E_{\max}^{3/2}$$

or

$$E_{\max}^{3/2} = \left(\frac{\hbar^2}{2m} \right)^{3/2} (3 \pi^2 n)$$

$$E_{\max} = \frac{\hbar^2}{2m} (3 \pi^2 n)^{2/3}$$

(b) Mean K.E. $\langle E \rangle$ is

$$\langle E \rangle = \frac{\int_0^{E_{\max}} E dn}{\int_0^{E_{\max}} dn}$$

$$= \frac{\int_0^{E_{\max}} E^{3/2} dE}{\int_0^{E_{\max}} E^{1/2} dE} = \frac{2}{5} E_{\max}^{5/2} / \frac{2}{3} E_{\max}^{3/2} = \frac{3}{5} E_{\max}$$

6.198 The fraction is

$$\eta = \frac{\int_{\frac{1}{2} E_{\max}}^{E_{\max}} E^{1/2} dE}{\int_0^{E_{\max}} E^{1/2} dE} = 1 - 2^{-3/2} = 0.646 \quad \text{or} \quad 64.6 \%$$

6.199 We calculate the concentration n of electron in the Na metal from

$$E_{\max} = E_F = \frac{\hbar^2}{2m} (3 \pi^2 n)^{2/3}$$

we get from

$$E_F = 3.07 \text{ eV}$$

$$n = 2.447 \times 10^{22} \text{ per c.c.}$$

From this we get the number of electrons per one Na atom as

$$\frac{n}{\rho} \cdot \frac{M}{N_A}$$

where ρ = density of Na , M = molar weight in gm of Na , N_A = Avogadro number

we get

0.963 electrons per one Na atom.

6.200 The mean K.E. of electrons in a Fermi gas is $\frac{3}{5}E_F$. This must equal $\frac{3}{2}kT$. Thus

$$T = \frac{2E_F}{5k}$$

We calculate E_F first. For Cu

$$n = \frac{N_A}{M/\rho} = \frac{\rho N_A}{M} = 8.442 \times 10^{22} \text{ per c.c.}$$

Then $E_F = 7.01 \text{ eV}$

and $T = 3.25 \times 10^4 \text{ K}$

6.201 We write the expression for the number of electrons as

$$dN = \frac{V \sqrt{2} m^{3/2}}{\pi^2 \hbar^3} E^{1/2} dE$$

Hence if ΔE is the spacing between neighbouring levels near the Fermi level we must have

$$2 = \frac{V \sqrt{2} m^{3/2}}{\pi^2 \hbar^3} E_F^{1/2} \Delta E$$

(2 on the RHS is to take care of both spins f electrons). Thus

$$\Delta E = \frac{\sqrt{2} \pi^2 \hbar^3}{V m^{3/2} E_F^{1/2}}$$

But $E_F^{1/2} = \frac{\hbar}{\sqrt{2} m^{1/2}} (3 \pi^2 n)^{1/3}$

So $\Delta E = \frac{2 \pi^2 \hbar^2}{m V (3 \pi^2 n)^{1/3}}$

Substituting the data we get

$$\Delta E = 1.79 \times 10^{-22} \text{ eV}$$

6.202 (a) From

$$dn(E) = \frac{\sqrt{2} m^{3/2}}{\pi^2 \hbar^3} E^{1/2} dE$$

we get on using $E = \frac{1}{2} m v^2$, $dn(E) = dn(v)$

$$dn(v) = \frac{\sqrt{2} m^{3/2}}{\pi^2 \hbar^3} \frac{1}{\sqrt{2}} m^{1/2} v m v dv = \frac{m^3}{\pi^2 \hbar^3} v^2 dv$$

This holds for $0 < v < v_F$ where $\frac{1}{2} m v_F^2 = E_F$

and $dn(v) = 0$ for $v > v_F$.

(b) Mean velocity is

$$\langle v \rangle = \frac{\int_0^{v_F} v^3 dv}{\int_0^{v_F} v^2 dv} = \frac{3}{4} v_F$$

$$\therefore \frac{\langle v \rangle}{v_F} = \frac{3}{4}.$$

6.203 Using the formula of the previous section

$$dn(v) = \frac{m^3}{\pi^2 \hbar^3} v^2 dv$$

We put $mv = \frac{2\pi\hbar}{\lambda}$, where λ = de Broglie wavelength

$$m dv = -\frac{2\pi\hbar}{\lambda^2} d\lambda$$

Taking account of the fact that λ decreases when v increases we write

$$dn(\lambda) = -dn(v) = \frac{(2\pi)^3 d\lambda}{\pi^2 \lambda^4} = \frac{8\pi}{\lambda^4} d\lambda$$

6.204 From the kinetic theory of gasses we know

$$p = \frac{2}{3} \frac{U}{V}$$

Here U is the total interval energy of the gas. This result is applicable to Fermi gas also
Now at $T = 0$

$$U = U_0 = N \langle E \rangle = nV \langle E \rangle$$

so

$$p = \frac{2}{3} n \langle E \rangle$$

$$= \frac{2}{3} n \times \frac{3}{5} E_F = \frac{2}{5} n E_F$$

$$= \frac{\hbar^2}{5m} (3\pi^2)^{2/3} n^{5/3}$$

Substituting the values we get

$$p = 4.92 \times 10^4 \text{ atmos}$$

6.205 From Richardson's equation

$$I = a T^2 e^{-A/kT}$$

where A is the work function in eV. When T increases by ΔT , I increases to $(1 + \eta)I$. Then

$$1 + \eta = \left(\frac{T + \Delta T}{T} \right)^2 e^{-\frac{A}{kT} \left(\frac{T}{T + \Delta T} - 1 \right)} = \left(1 + \frac{\Delta T}{T} \right)^2 e^{+\frac{A}{kT} \cdot \frac{\Delta T}{T + \Delta T}}$$

Expanding and neglecting higher powers of $\frac{\Delta T}{T}$ we get

$$\eta = 2 \frac{\Delta T}{T} + \frac{A}{kT^2} \Delta T$$

Thus

$$A = kT \left(\frac{\eta T}{\Delta T} - 2 \right)$$

Substituting we get

$$A = 4.48 \text{ eV}$$

6.206

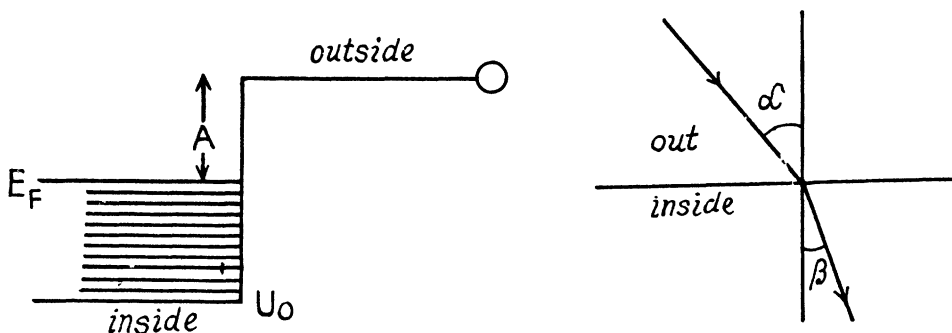

The potential energy inside the metal is $-U_0$ for the electron and it related to the work function A by

$$U_0 = E_F + A$$

If T is the K.E. of electrons outside the metal, its K.E. inside the metal will be $(E + U_0)$. On entering the metal electron cannot experience any tangential force so the tangential component of momentum is unchanged. Then

$$\sqrt{2mT} \sin \alpha = \sqrt{2m(T + U_0)} \sin \beta$$

Hence

$$\frac{\sin \alpha}{\sin \beta} = \sqrt{1 + \frac{U_0}{T}} = n \text{ by definition of refractive index.}$$

In sodium with one free electron per Na atom

$$n = 2.54 \times 10^{22} \text{ per c.c.}$$

$$E_F = 3.15 \text{ eV}$$

$$A = 2.27 \text{ eV (from table)}$$

$$U_0 = 5.42 \text{ eV}$$

$$n = 1.02$$

6.207 In a pure (intrinsic) semiconductor the conductivity is related to the temperature by the following formula very closely :

$$\sigma = \sigma_0 e^{-\Delta \epsilon / 2kT}$$

where $\Delta \epsilon$ is the energy gap between the top of valence band and the bottom of conduction band; it is also the minimum energy required for the formation of electron-hole pair. The conductivity increases with temperature and we have

$$\eta = e^{+\frac{\Delta \epsilon}{2k} \left(\frac{1}{T_1} - \frac{1}{T_2} \right)}$$

or

$$\ln \eta = \frac{\Delta \epsilon}{2k} \frac{T_2 - T_1}{T_1 T_2}$$

Hence

$$\Delta \epsilon = \frac{2k T_1 T_2}{T_2 - T_1} \ln \eta$$

Substitution gives

$$\Delta \epsilon = 0.333 \text{ eV} = E_{\text{min}}$$

6.208 The photoelectric threshold determines the band gap $\Delta \epsilon$ by

$$\Delta \epsilon = \frac{2\pi \hbar c}{\lambda_{\text{th}}}$$

On the other hand the temperature coefficient of resistance is defined by (ρ is resistivity)

$$\alpha = \frac{1}{\rho} \frac{d\rho}{dT} = \frac{d}{dT} \ln \rho = -\frac{d}{dT} \ln \sigma$$

where σ is the conductivity. But

$$\ln \sigma = \ln \sigma_0 - \frac{\Delta \epsilon}{2kT}$$

Then

$$\alpha = -\frac{\Delta \epsilon}{2kT^2} = -\frac{\pi \hbar c}{kT^2 \lambda_{\text{th}}} = -0.047 \text{ K}^{-1}$$

6.209 At high temperatures (small values of T^{-1}) most of the conductivity is intrinsic i.e. it is due to the transition of electrons from the upper levels of the valence band into the lower levels of conduction bands.

For this we can apply approximately the formula

$$\sigma = \sigma_0 \exp \left(-\frac{E_g}{2kT} \right)$$

or

$$\ln \sigma = \ln \sigma_0 - \frac{E_g}{2kt}$$

From this we get the band gap

$$E_g = -2k \frac{\Delta \ln \sigma}{\Delta (1/T)}$$

The slope must be calculated at small $\frac{1}{T}$. Evaluation gives $-\frac{\Delta \ln \sigma}{\Delta \left(\frac{1}{T}\right)} = 7000 \text{ K}$

Hence $E_g = 1.21 \text{ eV}$

At low temperatures (high values of $\frac{1}{T}$) the conductance is mostly due to impurities. If E_0 is the ionization energy of donor levels then we can write the approximate formula (valid at low temperature)

$$\sigma' = \sigma'_0 \exp\left(-\frac{E_0}{2kT}\right)$$

So $E_0 = -2kT \frac{\Delta \ln \sigma'}{\Delta \left(\frac{1}{T}\right)}$

The slope must be calculated at low temperatures. Evaluation gives the slope

$$-\frac{\Delta \ln \sigma'}{\Delta \left(\frac{1}{T}\right)} = \frac{1}{3} \times 1000 \text{ K}$$

Then $E_0 \sim 0.057 \text{ eV}$

6.210 We write the conductivity of the sample as $\sigma = \sigma_i + \sigma_\gamma$

where σ_i = intrinsic conductivity and σ_γ is the photo conductivity. At $t = 0$, assuming saturation we have

$$\frac{1}{\rho_1} = \frac{1}{\rho} + \sigma_{\gamma_0} \quad \text{or} \quad \sigma_{\gamma_0} = \frac{1}{\rho_1} - \frac{1}{\rho}$$

Time t after light source is switched off

we have because of recombination of electron and holes in the sample

$$\sigma = \sigma_i + \sigma_{\gamma_0} e^{-t/T}$$

where T = mean lifetime of electrons and holes.

Thus $\frac{1}{\rho_2} = \frac{1}{\rho} + \left(\frac{1}{\rho_1} - \frac{1}{\rho}\right) e^{-t/T}$

or $\frac{1}{\rho_2} - \frac{1}{\rho} = \left(\frac{1}{\rho_1} - \frac{1}{\rho}\right) e^{-t/T}$

or $e^{t/T} = \frac{\frac{1}{\rho_1} - \frac{1}{\rho}}{\frac{1}{\rho_2} - \frac{1}{\rho}} = \frac{\rho_2(\rho - \rho_1)}{\rho_1(\rho - \rho_2)}$

Hence $T = t / \ln \left\{ \frac{\rho_2(\rho - \rho_1)}{\rho_1(\rho - \rho_2)} \right\}$

Substitution gives $T = 9.87 \text{ ms} \sim 0.01 \text{ sec}$

6.211

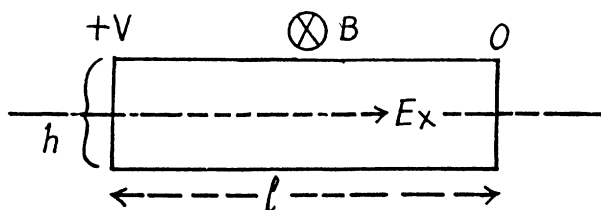

We shall ignore minority carriers.

Drifting holes experience a sideways force in the magnetic field and react by setting up a Hall electric field E_y to counterbalance it. Thus

$$v_x B = E_y = \frac{V_H}{h}$$

If the concentration of carriers is n then

$$j_x = n e v_x$$

Hence

$$n = \frac{J_x}{e v_x} = \frac{j_x}{e V_H} = \frac{j_x h B}{e V_H}$$

Also using

$$j_x = \sigma E_x = E_x / \rho = \frac{V}{\rho l}$$

we get

$$n = \frac{V h B}{e \rho l V_H}$$

Substituting the data (note that in MKS units $B = 5.0 \text{ kG} = 0.5 \text{ T}$)

$$\rho = 2.5 \times 10^{-2} \text{ ohm-m}$$

we get

$$\begin{aligned} n &= 4.99 \times 10^{21} \text{ m}^{-3} \\ &= 4.99 \times 10^{15} \text{ per cm}^3 \end{aligned}$$

Also the mobility is

$$u_0 = \frac{v_x}{E_x} = \frac{V_H}{n B} \times \frac{l}{V} = \frac{V_H l}{h B V}$$

Substitution gives

$$u_0 = 0.05 \text{ m}^2/\text{V-s}$$

6.212

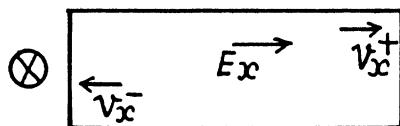

If an electric field E_x is present in a sample containing equal amounts of both electrons and holes, the two drift in opposite directions.

In the presence of a magnetic field $B_z = B$ they set up Hall voltages in opposite directions.

The net Hall electric field is given by

$$\begin{aligned} E_y &= (v_x^+ - v_x^-) B \\ &= (u_0^+ u_0^-) E_x B \end{aligned}$$

But

$$\frac{E_y}{E_x} = \frac{1}{\eta} \text{ Hence}$$

$$|u_0^+ - u_0^-| = \frac{1}{\eta B}$$

Substitution gives $|u_0^+ - u_0^-| = 0.2 \text{ m}^2/\text{volt} - \text{sec}$

6.213

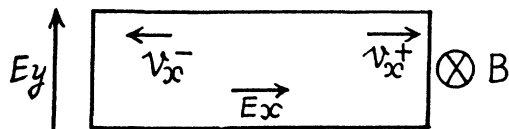

When the sample contains unequal number of carriers of both types whose mobilities are different, static equilibrium (i.e. no transverse movement of either electron or holes) is impossible in a magnetic field. The transverse electric field acts differently on electrons and holes. If the E_y that is set up is as shown, the net Lorentz force per unit charge (effective transverse electric field) on electrons is

$$E_y - v_x^- B$$

and on holes

$$E_y + v_x^+ B$$

(we are assuming $B = B_z$). There is then a transverse drift of electrons and holes and the net transverse current must vanish in equilibrium. Using mobility

$$u_0^- N_e e (E_y - u_0^- E_x B) + N_h e u_0^+ (E_y + u_0^+ E_x B) = 0$$

or

$$E_y = \frac{N_e u_0^{-2} - N_h u_0^{+2}}{N_e u_0^- + N_h u_0^+} E_x B$$

On the other hand

$$j_x = (N_e u_0^- + N_h u_0^+) e E_x$$

Thus, the Hall coefficient is

$$R_H = \frac{E_y}{j_x B} = \frac{1}{e} \frac{N_e u_0^{-2} - N_h u_0^{+2}}{(N_e u_0^- + N_h u_0^+)}$$

We see that $R_H = 0$ when

$$\frac{N_e}{N_h} = \left(\frac{u_0^+}{u_0^-} \right)^2 = \frac{1}{\eta^2} = \frac{1}{4}$$

6.5 RADIOACTIVITY

6.214 (a) The probability of survival (i.e. not decaying) in time t is $e^{-\lambda t}$. Hence the probability of decay is $1 - e^{-\lambda t}$

(b) The probability that the particle decays in time dt around time t is the difference

$$e^{-\lambda t} - e^{-\lambda(t+dt)} = e^{-\lambda t} [1 - e^{-\lambda dt}] = \lambda e^{-\lambda t} dt$$

Therefore the mean life time is

$$T = \int_0^{\infty} t \lambda e^{-\lambda t} dt / \int_0^{\infty} \lambda e^{-\lambda t} dt = \frac{1}{\lambda} \int_0^{\infty} x e^{-x} dx / \int_0^{\infty} e^{-x} dx = \frac{1}{\lambda}$$

6.215 We calculate λ first

$$\lambda = \frac{\ln 2}{T_{1/2}} = 9.722 \times 10^{-3} \text{ per day}$$

Hence

$$\text{fraction decaying in a month} = 1 - e^{-\lambda t} = 0.253$$

6.216 Here $N_0 = \frac{1 \mu\text{g}}{24 \text{g}} \times 6.023 \times 10^{23} = 2.51 \times 10^{16}$

$$\text{Also} \quad \lambda = \frac{\ln 2}{T_{1/2}} = 0.04621 \text{ per hour}$$

So the number of β rays emitted in one hour is

$$N_0 (1 - e^{-\lambda}) = 1.13 \times 10^{15}$$

6.217 If N_0 is the number of radionuclei present initially, then

$$N_1 = N_0 (1 - e^{-t_1/\tau})$$

$$\eta N_1 = N_0 (1 - e^{-t_2/\tau})$$

where

$$\eta = 2.66 \text{ and } t_2 = 3 t_1. \text{ Then}$$

$$\eta = \frac{1 - e^{-t_2/\tau}}{1 - e^{-t_1/\tau}}$$

or

$$\eta - \eta e^{-t_1/\tau} = 1 - e^{-t_2/\tau}$$

Substituting the values

$$1.66 = 2.66 e^{-2/\tau} - e^{-6/\tau}$$

Put $e^{-2/\tau} = x$. Then

$$\begin{aligned} x^3 - 2.66x + 1.66 &= 0 \\ (x^2 - 1)x - 1.66(x - 1) &= 0 \end{aligned}$$

or $(x-1)(x^2+x-1.66) = 0$
 Now $x \neq 1$ so $x^2+x-1.66 = 0$

$$x = \frac{-1 \pm \sqrt{1+4 \times 1.66}}{2}$$

Negative sign has to be rejected as $x > 0$.

Thus $x = 0.882$

This gives $\tau = \frac{-2}{\ln 0.882} = 15.9 \text{ sec.}$

6.218 If the half-life is T days

$$(2)^{-7/T} = \frac{1}{2.5}$$

Hence $\frac{7}{T} = \frac{\ln 2.5}{\ln 2}$

or $T = \frac{7 \ln 2}{\ln 2.5} = 5.30 \text{ days.}$

6.219 The activity is proportional to the number of parent nuclei (assuming that the daughter is not radioactive). In half its half-life period, the number of parent nuclei decreases by a factor

$$(2)^{-1/2} = \frac{1}{\sqrt{2}}$$

So activity decreases to $\frac{650}{\sqrt{2}} = 460 \text{ particles per minute.}$

6.220 If the decay constant (in $(\text{hour})^{-1}$) is λ , then the activity after one hour will decrease by a factor $e^{-\lambda}$. Hence

$$0.96 = e^{-\lambda}$$

or $\lambda = 1.11 \times 10^{-5} \text{ s}^{-1} = 0.0408 \text{ per hour}$

The mean life time is 24.5 hour

6.221 Here $N_0 = \frac{1}{238} \times 6.023 \times 10^{23}$
 $= 2.531 \times 10^{21}$

The activity is $A = 1.24 \times 10^4 \text{ dis/sec.}$

Then $\lambda = \frac{A}{N_0} = 4.90 \times 10^{-18} \text{ per sec.}$

Hence the half life is

$$T_{\frac{1}{2}} = \frac{\ln 2}{\lambda} = 4.49 \times 10^9 \text{ years}$$

- 6.222** In old wooden atoms the number of C^{14} nuclei steadily decreases because of radioactive decay. (In live trees biological processes keep replenishing C^{14} nuclei maintaining a balance. This balance starts getting disrupted as soon as the tree is felled.)

If $T_{1/2}$ is the half life of C^{14} then $e^{-t \times \frac{\ln 2}{T_{1/2}}} = \frac{3}{5}$

Hence $t = T_{1/2} \frac{\ln 5/3}{\ln 2} = 4105 \text{ years} \approx 4.1 \times 10^3 \text{ years}$

- 6.223** What this implies is that in the time since the ore was formed, $\frac{\eta}{1+\eta} U^{238}$ nuclei have remained undecayed. Thus

$$\frac{\eta}{1+\eta} = e^{-t \times \frac{\ln 2}{T_{1/2}}}$$

or
$$t = T_{1/2} \frac{\ln \frac{1+\eta}{\eta}}{\ln 2}$$

Substituting $T_{1/2} = 4.5 \times 10^9 \text{ years}$, $\eta = 2.8$

we get $t = 1.98 \times 10^9 \text{ years}$.

- 6.224** The specific activity of Na^{24} is

$$\lambda \frac{N_A}{M} = \frac{N_A \ln 2}{M T_{1/2}} = 3.22 \times 10^{17} \text{ dis}/(\text{gm}\cdot\text{sec})$$

Here M = molar weight of $Na^{24} = 24 \text{ gm}$, N_A is Avogadro number & $T_{1/2}$ is the half-life of Na^{24} .

Similarly the specific activity of U^{235} is

$$\frac{6.023 \times 10^{23} \times \ln 2}{235 \times 10^8 \times 365 \times 86400} \\ = 0.793 \times 10^5 \text{ dis}/(\text{gm}\cdot\text{s})$$

- 6.225** Let V = volume of blood in the body of the human being. Then the total activity of the blood is $A' V$. Assuming all this activity is due to the injected Na^{24} and taking account of the decay of this radionuclide, we get

$$VA' = A e^{-\lambda t}$$

Now $\lambda = \frac{\ln 2}{15} \text{ per hour}$, $t = 5 \text{ hour}$

Thus $V = \frac{A}{A'} e^{-\ln 2/3} = \frac{2.0 \times 10^3}{(16/60)} e^{-\ln 2/3} \text{ cc} = 5.95 \text{ litre}$

6.226 We see that

Specific activity of the sample

$$= \frac{1}{M+M'} \{\text{Activity of } M \text{ gm of } Co^{58} \text{ in the sample}\}$$

Here M and M' are the masses of Co^{58} and Co^{59} in the sample. Now activity of M gm of Co^{58}

$$= \frac{M}{58} \times 6.023 \times 10^{23} \times \frac{\ln 2}{71.3 \times 86400} \text{ dis/sec}$$

$$= 1.168 \times 10^{15} \text{ M}$$

Thus from the problem

$$1.168 \times 10^{15} \frac{M}{M+M'} = 2.2 \times 10^{12}$$

or

$$\frac{M}{M+M'} = 1.88 \times 10^{-3} \text{ i.e. } 0.188 \%$$

6.227 Suppose N_1, N_2 are the initial number of component nuclei whose decay constants are λ_1, λ_2 (in (hour) $^{-1}$)

Then the activity at any instant is

$$A = \lambda_1 N_1 e^{-\lambda_1 t} + \lambda_2 N_2 e^{-\lambda_2 t}$$

The activity so defined is in units dis/hour. We assume that data $\ln A$ given is of its natural logarithm. The daughter nuclei are assumed nonradioactive.

We see from the data that at large t the change in $\ln A$ per hour of elapsed time is constant and equal to -0.07 . Thus

$$\lambda_2 = 0.07 \text{ per hour}$$

We can then see that the best fit to data is obtained by

$$A(t) = 51.1 e^{-0.66 t} + 10.0 e^{-0.07 t}$$

[To get the fit we calculate $A(t) e^{0.07 t}$. We see that it reaches the constant value 10.0 at $t = 7, 10, 14, 20$ very nearly. This fixes the second term. The first term is then obtained by subtracting out the constant value 10.0 from each value of $A(t) e^{0.07 t}$ in the data for small t .]

Thus we get $\lambda_1 = 0.66$ per hour

$$\left. \begin{array}{l} T_1 = 1.05 \text{ hour} \\ T_2 = 9.9 \text{ hours} \end{array} \right\} \text{ half-lives}$$

Ratio

$$\frac{N_1}{N_2} = \frac{51.1}{10.0} \times \frac{\lambda_2}{\lambda_1} = 0.54$$

The answer given in the book is misleading.

6.228 Production of the nucleus is governed by the equation

$$\frac{dN}{dt} = g - \lambda N$$

\uparrow supply \searrow decay

We see that N will approach a constant value $\frac{g}{\lambda}$. This can also be proved directly. Multiply by $e^{\lambda t}$ and write

$$\frac{dN}{dt} e^{\lambda t} + \lambda e^{\lambda t} N = g e^{\lambda t}$$

Then
$$\frac{d}{dt}(N e^{\lambda t}) = g e^{\lambda t}$$

or
$$N e^{\lambda t} = \frac{g}{\lambda} e^{\lambda t} + \text{const}$$

At $t = 0$ when the production is started, $N = 0$

$$0 = \frac{g}{\lambda} + \text{constant}$$

Hence
$$N = \frac{g}{\lambda} (1 - e^{-\lambda t})$$

Now the activity is

$$A = \lambda N = g(1 - e^{-\lambda t})$$

From the problem

$$\frac{1}{2.7} = 1 - e^{-\lambda t}$$

This gives $\lambda t = 0.463$

so
$$t = \frac{0.463}{\lambda} = \frac{0.463 \times T}{0.693} = 9.5 \text{ days.}$$

Algebraically

$$t = -\frac{T}{\ln 2} \ln \left(1 - \frac{A}{g}\right)$$

6.229 (a) Suppose N_1 and N_2 are the number of two radionuclides A_1 , A_2 at time t . Then

$$\frac{dN_1}{dt} = -\lambda_1 N_1 \quad (1)$$

$$\frac{dN_2}{dt} = \lambda_1 N_1 - \lambda_2 N_2 \quad (2)$$

From (1)

$$N_1 = N_{10} e^{-\lambda_1 t}$$

where N_{10} is the initial number of nuclides A_1 at time $t = 0$

From (2)

$$\left(\frac{dN_2}{dt} + \lambda_2 N_2\right) e^{\lambda_2 t} = \lambda_1 N_{10} e^{-(\lambda_1 - \lambda_2)t}$$

or $(N_2 e^{\lambda_2 t}) = \text{const} \frac{\lambda_1 N_{10}}{\lambda_1 - \lambda_2} e^{-(\lambda_1 - \lambda_2)t}$

since $N_2 = 0$ at $t = 0$

Constant $N_2 = \frac{\lambda_1 N_{10}}{\lambda_1 - \lambda_2}$

Thus $= \frac{\lambda_1 N_{10}}{\lambda_1 - \lambda_2} (e^{-\lambda_2 t} - e^{-\lambda_1 t})$

(b) The activity of nuclide A_2 is $\lambda_2 N_2$. This is maximum when N_2 is maximum. That happens when $\frac{dN_2}{dt} = 0$

This requires $\lambda_2 e^{-\lambda_2 t_m} = \lambda_1 e^{-\lambda_1 t_m}$

or $t_m = \frac{\ln(\lambda_1/\lambda_2)}{\lambda_1 - \lambda_2}$

6.230 (a) This case can be obtained from the previous one on putting

$$\lambda_2 = \lambda_1 - \varepsilon$$

where ε is very small and letting $\varepsilon \rightarrow 0$ at the end. Then

$$N_2 = \frac{\lambda_1 N_{10}}{\varepsilon} (e^{\varepsilon t} - 1) e^{-\lambda_1 t} = \lambda_1 t e^{-\lambda_1 t} N_{10}$$

or dropping the subscript 1 as the two values are equal

$$N_2 = N_{10} \lambda t e^{-\lambda t}$$

(b) This is maximum when

$$\frac{dN_2}{dt} = 0 \quad \text{or} \quad t = \frac{1}{\lambda}$$

6.231 Here we have the equations

$$\frac{dN_1}{dt} = -\lambda_1 N_1$$

$$\frac{dN_2}{dt} = \lambda_1 N_1 - \lambda_2 N_2 \quad \text{and} \quad \frac{dN_3}{dt} = \lambda_2 N_2$$

From problem 229

$$N_1 = N_{10} e^{-\lambda_1 t}$$

$$N_2 = \frac{\lambda_1 N_{10}}{\lambda_1 - \lambda_2} (e^{-\lambda_2 t} - e^{-\lambda_1 t})$$

Then $\frac{dN_3}{dt} = \frac{\lambda_1 \lambda_2}{\lambda_1 - \lambda_2} N_{10} (e^{-\lambda_2 t} - e^{-\lambda_1 t})$

or
$$N_3 = \text{Const} - \frac{\lambda_1 \lambda_2}{\lambda_1 - \lambda_2} \left(\frac{e^{-\lambda_2 t}}{\lambda_2} - \frac{e^{-\lambda_1 t}}{\lambda_1} \right) N_{10}$$

since $N_3 = 0$ initially

$$\text{Const} = \frac{\lambda_1 \lambda_2}{\lambda_1 - \lambda_2} N_{10} \left(\frac{1}{\lambda_2} - \frac{1}{\lambda_1} \right)$$

So
$$N_3 = \frac{\lambda_1 \lambda_2 N_{10}}{\lambda_1 - \lambda_2} \left[\frac{1}{\lambda_2} (1 - e^{-\lambda_2 t}) - \frac{1}{\lambda_1} (1 - e^{-\lambda_1 t}) \right]$$

$$= N_{10} \left[1 + \frac{\lambda_1 e^{-\lambda_2 t} - \lambda_2 e^{-\lambda_1 t}}{\lambda_2 - \lambda_1} \right]$$

6.232 We have the chain

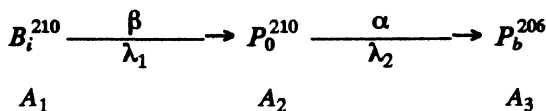

of the previous problem initially

$$N_{10} = \frac{10^{-3}}{210} \times 6.023 \times 10^{23} = 2.87 \times 10^{18}$$

A month after preparation

$$N_1 = 4.54 \times 10^{16}$$

$$N_2 = 2.52 \times 10^{18}$$

using the results of the previous problem.

Then

$$A_\beta = \lambda_1 N_1 = 0.725 \times 10^{11} \text{ dis/sec}$$

$$A_\alpha = \lambda_2 N_2 = 1.46 \times 10^{11} \text{ dis/sec}$$

6.233 (a) Ra has $Z = 88$, $A = 226$

After 5 α emission and 4 β (electron) emission

$$A = 206$$

$$Z = 88 + 4 - 5 \times 2 = 82$$

The product is ${}^{82}\text{Pb}^{206}$

(b) We require

$$-\Delta Z = 10 = 2n - m$$

$$-\Delta A = 32 = n \times 4$$

Here

n = no. of α emissions

m = no. of β emissions

Thus

$$n = 8, m = 6$$

6.234 The momentum of the α -particle is

$\sqrt{2M_\alpha T}$. This is also the recoil momentum of the daughter nuclear in opposite direction.

The recoil velocity of the daughter nucleus is

$$\frac{\sqrt{2M_\alpha T}}{M_d} = \frac{2}{196} \sqrt{\frac{2T}{M_p}} = 3.39 \times 10^5 \text{ m/s}$$

The energy of the daughter nucleus is $\frac{M_\alpha}{M_d} T$ and this represents a fraction

$$\frac{\frac{M_\alpha/M_d}{1 + \frac{M_\alpha}{M_d}} = \frac{M_\alpha}{M_\alpha + M_d} = \frac{4}{200} = \frac{1}{50} = 0.02$$

of total energy. Here M_d is the mass of the daughter nucleus.

6.235 The number of nuclei initially present is

$$\frac{10^{-3}}{210} \times 6.023 \times 10^{23} = 2.87 \times 10^{18}$$

In the mean life time of these nuclei the number decaying is the fraction $1 - \frac{1}{e} = 0.632$. Thus the energy released is

$$2.87 \times 10^{18} \times 0.632 \times 5.3 \times 1.602 \times 10^{-13} \text{ J} = 1.54 \text{ MJ}$$

6.236 We neglect all recoil effects. Then the following diagram gives the energy of the gamma ray

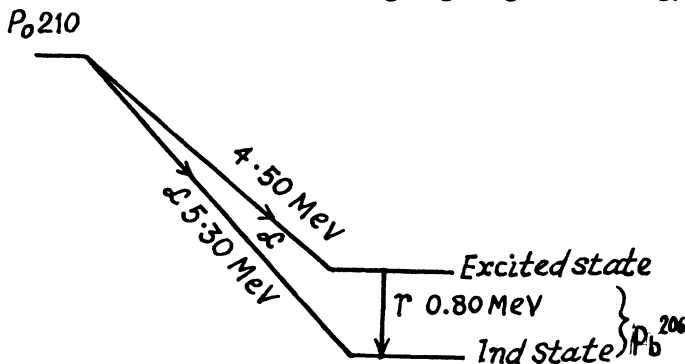

6.237 (a) For an alpha particle with initial K.E. 7.0 MeV, the initial velocity is

$$\begin{aligned} v_0 &= \sqrt{\frac{2T}{M_\alpha}} \\ &= \sqrt{\frac{2 \times 7 \times 1.602 \times 10^{-6}}{4 \times 1.672 \times 10^{-24}}} \\ &= 1.83 \times 10^9 \text{ cm/sec} \end{aligned}$$

Thus

$$R = 6.02 \text{ cm}$$

(b) Over the whole path the number of ion pairs is

$$\frac{7 \times 10^6}{34} = 2.06 \times 10^5$$

Over the first half of the path :- We write the formula for the mean path as $R \propto E^{3/2}$ where E is the initial energy. Thus if the energy of the α -particle after traversing the first half of the path is E_1 then

$$R_0 E_1^{3/2} = \frac{1}{2} R_0 E_0^{3/2} \quad \text{or} \quad E_1 = 2^{-2/3} E_0$$

Hence number of ion pairs formed in the first half of the path length is

$$\frac{E_0 - E_1}{34 e V} = (1 - 2^{-2/3}) \times 2.06 \times 10^5 = 0.76 \times 10^5$$

6.238 In β^- decay

$$\begin{aligned} Z X^A &\rightarrow {}_{Z+1} Y^A + e^- + Q \\ Q &= (M_x - M_y - m_e) c^2 \\ &= [(M_x + Z m_e) - (M_y + Z m_e + m_e)] c^2 \\ &= (M_p - M_d) c^2 \end{aligned}$$

since M_p, M_d are the masses of the atoms. The binding energy of the electrons is ignored.

In K capture

$$\begin{aligned} e^- + {}_Z X^A &\rightarrow {}_{Z-1} Y^A + Q \\ Q &= (M_x - M_y) c^2 + m_e c^2 \\ &= (M_x^2 + Z m_e c^2) - (M_y c^2 + (Z-1) m_e c^2) \\ &= c^2 (M_p - M_d) \end{aligned}$$

In β^+ decay

$${}_Z X^A \rightarrow {}_{Z-1} Y^A + e^+ + Q$$

Then

$$\begin{aligned} Q &= (M_x - M_y - m_e) c^2 \\ &= [M_x + Z m_e] c^2 - [M_y + (Z-1) m_e] c^2 - 2 m_e c^2 \\ &= (M_p - M_d - 2 m_e) c^2 \end{aligned}$$

6.239 The reaction is $Be^{10} \rightarrow B^{10} + e^- + \bar{\nu}_e$

For maximum K.E. of electrons we can put the energy of $\bar{\nu}_e$ to be zero. The atomic masses are

$$Be^{10} = 10.016711 \text{ amu}$$

$$B^{10} = 10.016114 \text{ amu}$$

So the K.E. of electrons is (see previous problem)

$$597 \times 10^{-6} \text{ amu} \times c^2 = 0.56 \text{ MeV}$$

The momentum of electrons with this K.E. is $0.941 \frac{\text{MeV}}{c}$

and the recoil energy of the daughter is

$$\frac{(0.941)^2}{2 \times M_d c^2} = \frac{(0.941)^2}{2 \times 10 \times 938} \text{ MeV} = 47.2 \text{ eV}$$

6.240 The masses are

$$Na^{24} = 24 - 0.00903 \text{ amu} \quad \text{and} \quad Mg^{24} = 24 - 0.01496 \text{ amu}$$

The reaction is

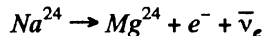

The maximum K.E. of electrons is

$$0.00593 \times 93 \text{ MeV} = 5.52 \text{ MeV}$$

Average K.E. according to the problem is then $\frac{5.52}{3} = 1.84 \text{ MeV}$

The initial number of Na^{24} is

$$\frac{10^{-3} \times 6.023 \times 10^{23}}{24} = 2.51 \times 10^{19}$$

The fraction decaying in a day is

$$1 - (2)^{-24/15} = 0.67$$

Hence the heat produced in a day is

$$0.67 \times 2.51 \times 10^{19} \times 1.84 \times 1.602 \times 10^{-13} \text{ Joule} = 4.95 \text{ MJ}$$

6.241 We assume that the parent nucleus is at rest. Then since the daughter nucleus does not recoil, we have

$$\vec{p} = -\vec{p}_\nu$$

i.e. positron & ν momentum are equal and opposite. On the other hand

$\sqrt{c^2 p^2 + m_e^2 c^4} + c p = Q = \text{total energy released.}$ (Here we have used the fact that energy of the neutrino is $c |\vec{p}_\nu| = c p$)

$$\begin{aligned} \text{Now} \quad Q &= [(\text{Mass of } C^{\parallel} \text{ nucleus}) - (\text{Mass of } B^{\parallel} \text{ nucleus})] c^2 \\ &= [\text{Mass of } C^{\parallel} \text{ atom} - \text{Mass of } B^{\parallel} \text{ atom} - m_e] c^2 \\ &= 0.00213 \text{ amu} \times c^2 - m_e c^2 \\ &= (0.00213 \times 931 - 0.511) \text{ MeV} = 1.47 \text{ MeV} \end{aligned}$$

$$\text{Then} \quad c^2 p^2 + (0.511)^2 = (1.47 - c p)^2 = (1.47)^2 - 2.94 c p + c^2 p^2$$

Thus $c p = 0.646 \text{ MeV} = \text{energy of neutrino}$

$$\text{Also K.E. of electron} = 1.47 - 0.646 - 0.511 = 0.313 \text{ MeV}$$

6.242 The K.E. of the positron is maximum when the energy of neutrino is zero. Since the recoil energy of the nucleus is quite small, it can be calculated by successive approximation. The reaction is

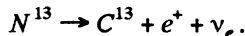

The maximum energy available to the positron (including its rest energy) is

$$\begin{aligned} & c^2 (\text{Mass of } N^{13} \text{ nucleus} - \text{Mass of } C^{13} \text{ nucleus}) \\ &= c^2 (\text{Mass of } N^{13} \text{ atom} - \text{Mass of } C^{13} \text{ atom} - m_e) \\ &= 0.00239 c^2 - m_e c^2 \\ &= (0.00239 \times 931 - 0.511) \text{ MeV} \\ &= 1.71 \text{ MeV} \end{aligned}$$

The momentum corresponding to this energy is $1.636 \text{ MeV}/c$.

The recoil energy of the nucleus is then

$$E = \frac{p^2}{2M} = \frac{(1.636)^2}{2 \times 13 \times 931} = 111 \text{ eV} = 0.111 \text{ keV}$$

on using $Mc^2 = 13 \times 931 \text{ MeV}$

6.243 The process is

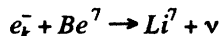

The energy available in the process is

$$\begin{aligned} Q &= c^2 (\text{Mass of } Be^7 \text{ atom} - \text{Mass of } Li^7 \text{ atom}) \\ &= 0.00092 \times 931 \text{ MeV} = 0.86 \text{ MeV} \end{aligned}$$

The momentum of a K electron is negligible. So in the rest frame of the Be^7 atom, most of the energy is taken by neutrino whose momentum is very nearly $0.86 \text{ MeV}/c$

The momentum of the recoiling nucleus is equal and opposite. The velocity of recoil is

$$\frac{0.86 \text{ MeV}/c}{M_{Li}} = c \times \frac{0.86}{7 \times 931} = 3.96 \times 10^6 \text{ cm/s}$$

6.244 In internal conversion, the total energy is used to knock out K electrons. The K.E. of these electrons is energy available - B.E. of K electrons

$$= (87 - 26) = 61 \text{ keV}$$

The total energy including rest mass of electrons is $0.511 + 0.061 = 0.572 \text{ MeV}$

The momentum corresponding to this total energy is

$$\sqrt{(0.572)^2 - (0.511)^2} / c = 0.257 \text{ MeV}/c.$$

The velocity is then $\frac{c^2 p}{E} = c \times \frac{0.257}{0.572} = 0.449 c$

- 6.245 With recoil neglected, the γ -quantum will have 129 keV energy. To a first approximation, its momentum will be 129 keV/c and the energy of recoil will be

$$\frac{(0.129)^2}{2 \times 191 \times 931} \text{ MeV} = 4.18 \times 10^{-8} \text{ MeV}$$

In the next approximation we therefore write $E_\gamma \approx 129 - 8.2 \times 10^{-8} \text{ MeV}$

Therefore

$$\frac{\delta E_\gamma}{E_\gamma} = 3.63 \times 10^{-7}$$

- 6.246 For maximum (resonant) absorption, the absorbing nucleus must be moving with enough speed to cancel the momentum of the oncoming photon and have just right energy ($\epsilon = 129 \text{ keV}$) available for transition to the excited state.

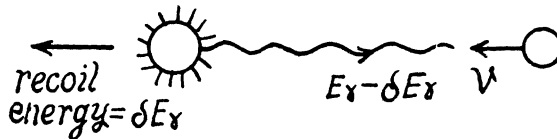

Since $\delta E_\gamma \approx \frac{\epsilon^2}{2Mc^2}$ and momentum of the photon is $\frac{\epsilon}{c}$, these conditions can be satisfied if the velocity of the nucleus is

$$\frac{\epsilon}{Mc} = c \frac{\epsilon}{Mc^2} = 218 \text{ m/s} = 0.218 \text{ km/s}$$

- 6.247 Because of the gravitational shift the frequency of the gamma ray at the location of the absorber is increased by

$$\frac{\delta \omega}{\omega} = \frac{gh}{c^2}$$

For this to be compensated by the Doppler shift (assuming that resonant absorption is possible in the absence of gravitational field) we must have

$$\frac{gh}{c^2} = \frac{v}{c} \quad \text{or} \quad v = \frac{gh}{c} = 0.65 \mu \text{ m/s}$$

- 6.248 The natural life time is

$$\Gamma = \frac{\hbar}{\tau} = 4.7 \times 10^{-10} \text{ eV}$$

Thus the condition $\delta E_\gamma \geq \Gamma$ implies $\frac{gh}{c^2} \geq \frac{\Gamma}{\epsilon} = \frac{\hbar}{\tau \epsilon}$

or

$$h \geq \frac{c^2 \hbar}{\tau \epsilon g} = 4.64 \text{ metre}$$

(h here is height of the place, not Planck's constant.)

6.6 NUCLEAR REACTIONS

6.249 Initial momentum of the α particle is $\sqrt{2mT_\alpha} \hat{i}$ (where \hat{i} is a unit vector in the incident direction). Final momenta are respectively \vec{p}_α and \vec{p}_{Li} . Conservation of momentum reads

$$\vec{p}_\alpha + \vec{p}_{Li} = \sqrt{2mT_\alpha} \hat{i}$$

Squaring
$$p_\alpha^2 + p_{Li}^2 + 2p_\alpha p_{Li} \cos \Theta = 2mT_\alpha \quad (1)$$

where Θ is the angle between \vec{p}_α and \vec{p}_{Li} .

Also by energy conservation
$$\frac{p_\alpha^2}{2m} + \frac{p_{Li}^2}{2M} = T_\alpha$$

(m & M are respectively the masses of α particle and Li^6 .) So

$$p_\alpha^2 + \frac{m}{M} p_{Li}^2 = 2mT_\alpha \quad (2)$$

Subtracting (2) from (1) we see that

$$p_{Li} \left[\left(1 - \frac{m}{M}\right) p_{Li} + 2p_\alpha \cos \Theta \right] = 0$$

Thus if
$$p_{Li} \neq 0$$

$$p_\alpha = -\frac{1}{2} \left(1 - \frac{m}{M}\right) p_{Li} \sec \Theta.$$

Since p_α , p_{Li} are both positive number (being magnitudes of vectors) we must have

$$-1 \leq \cos \Theta < 0 \quad \text{if } m < M.$$

This being understood, we write

$$\frac{p_{Li}^2}{2M} \left[1 + \frac{M}{4m} \left(1 - \frac{m}{M}\right)^2 \sec^2 \Theta \right] = T_\alpha$$

Hence the recoil energy of the Li nucleus is

$$\frac{p_{Li}^2}{2M} = \frac{T_\alpha}{1 + \frac{(M-m)^2}{4mM} \sec^2 \Theta}$$

As we pointed out above $\Theta \neq 60^\circ$. If we take $\Theta = 120^\circ$, we get recoil energy of $Li = 6 \text{ MeV}$

6.250 (a) In a head on collision

$$\sqrt{2mT} = p_d + p_n$$

$$T = \frac{p_d^2}{2M} + \frac{p_n^2}{2m}$$

Where p_d and p_n are the momenta of deuteron and neutron after the collision. Squaring

$$p_d^2 + p_n^2 + 2p_d p_n = 2mT$$

$$p_n^2 + \frac{m}{M} p_d^2 = 2mT$$

or since $p_d \neq 0$ in a head on collisions

$$p_n = -\frac{1}{2} \left(1 - \frac{m}{M} \right) p_d.$$

Going back to energy conservation

$$\frac{p_d^2}{2M} \left[1 + \frac{M}{4m} \left(1 - \frac{m}{M} \right)^2 \right] = T$$

So

$$\frac{p_d^2}{2M} = \frac{4mM}{(m+M)^2} T$$

This is the energy lost by neutron. So the fraction of energy lost is

$$\eta = \frac{4mM}{(m+M)^2} = \frac{8}{9}$$

(b) In this case neutron is scattered by 90° . Then we have from the diagram

$$\vec{p}_d = p_n \hat{j} + \sqrt{2mT} \hat{i}$$

Then by energy conservation

$$\frac{p_n^2 + 2mT}{2M} + \frac{p_n^2}{2m} = T$$

or

$$\frac{p_n^2}{2m} \left(1 + \frac{m}{M} \right) = T \left(1 - \frac{m}{M} \right)$$

or

$$\frac{p_n^2}{2m} = \frac{M-m}{M+m} T$$

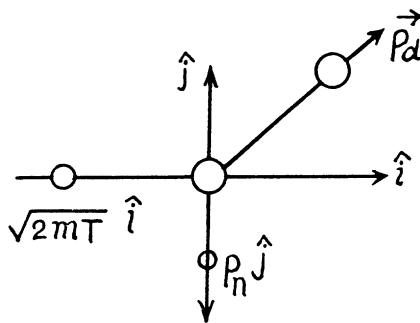

The energy lost by neutron is then

$$T - \frac{p_n^2}{2m} = \frac{2m}{M+m} T$$

or fraction of energy lost is $\eta = \frac{2m}{M+m} = \frac{2}{3}$

6.251 From conservation of momentum

$$\sqrt{2MT} \hat{i} = \vec{p}_d + \vec{p}_p$$

or $p_p^2 = 2MT + p_d^2 - 2\sqrt{2MT} p_d \cos \theta$

From energy conservation

$$T = \frac{p_d^2}{2M} + \frac{p_p^2}{2m}$$

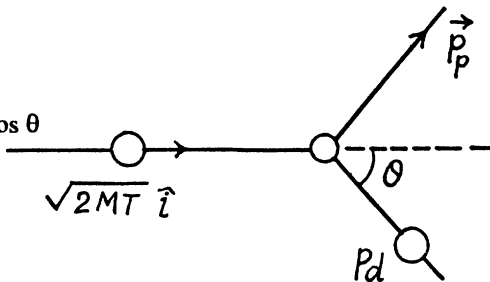

(M = mass of deuteron, m = mass of proton)

So
$$p_p^2 = 2 m T - \frac{m}{M} p_d^2 .$$

Hence
$$p_d^2 \left(1 + \frac{m}{M} \right) - 2 \sqrt{2 M T} p_d \cos \theta + 2 (M - m) T = 0$$

For real roots
$$4 (2 M T) \cos^2 \theta - 4 \times 2 (M - m) T \left(1 + \frac{m}{M} \right) \geq 0$$

$$\cos^2 \theta \geq \left(1 - \frac{m^2}{M^2} \right)$$

Hence
$$\sin^2 \theta \leq \frac{m^2}{M^2}$$

i.e.
$$\theta \leq \sin^{-1} \frac{m}{M}$$

For deuteron-proton scattering $\theta_{\max} = 30^\circ$.

6.252 This problem has a misprint. Actually the radius R of a nucleus is given by

$$R = 1.3 \sqrt[3]{A} \text{ fm}$$

where

$$1 \text{ fm} = 10^{-15} \text{ m} .$$

Then the number of nucleons per unit volume is

$$\frac{A}{\frac{4}{3} \pi R^3} = \frac{3}{4 \pi} \times (1.3)^{-3} \times 10^{+39} \text{ cm}^{-3} = 1.09 \times 10^{38} \text{ per cc}$$

The corresponding mass density is

$$(1.09 \times 10^{38} \times \text{mass of a nucleon}) \text{ per cc} = 1.82 \times 10^{11} \text{ kg/cc}$$

6.253 (a) The particle x must carry two nucleons and a unit of positive charge.

The reaction is

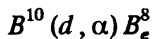

(b) The particle x must contain a proton in addition to the constituents of O^{17} . Thus the reaction is

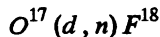

(c) The particle x must carry nucleon number 4 and two units of +ve charge. Thus the particle must be $x = \alpha$ and the reaction is

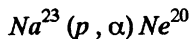

(d) The particle x must carry mass number 37 and have one unit less of positive charge. Thus $x = Cl^{37}$ and the reaction is

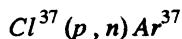

6.254 From the basic formula

$$E_b = Z m_H + (A - Z) m_n - M$$

We define

$$\Delta_H = m_H - 1 \text{ amu}$$

$$\Delta_n = m_n - 1 \text{ amu}$$

$$\Delta = M - A \text{ amu}$$

Then clearly $E_b = Z \Delta_H + (A - Z) \Delta_n - \Delta$

6.255 The mass number of the given nucleus must be

$$27 / \left(\frac{3}{2}\right)^3 = 8$$

Thus the nucleus is Be^8 . Then the binding energy is

$$\begin{aligned} E_b &= 4 \times 0.00867 + 4 \times 0.00783 - 0.00531 \text{ amu} \\ &= 0.06069 \text{ amu} = 56.5 \text{ MeV} \end{aligned}$$

On using 1 amu = 931 MeV.

6.256 (a) Total binding energy of the O^{16} nucleus is

$$\begin{aligned} E_b &= 8 \times 0.00867 + 8 \times 0.00783 + 0.00509 \text{ amu} \\ &= 0.13709 \text{ amu} = 127.6 \text{ MeV} \end{aligned}$$

So B.E. per nucleon is 7.98 MeV/nucleon

(b) B.E. of neutron in B^{11} nucleus

$$= \text{B.E. of } B^{11} - \text{B.E. of } B^{10}$$

(since on removing a neutron from B^{11} we get B^{10})

$$\begin{aligned} &= \Delta_n - \Delta_{B^{11}} + \Delta_{B^{10}} = 0.00867 - 0.00930 + 0.01294 \\ &= 0.01231 \text{ amu} = 11.46 \text{ MeV} \end{aligned}$$

B.E. of (an α -particle in B^{11})

$$= \text{B.E. of } B^{11} - \text{B.E. of } Li^7 - \text{B.E. of } \alpha$$

(since on removing an α from B^{11} we get Li^7)

$$\begin{aligned} &= -\Delta_{B^{11}} + \Delta_{Li^7} + \Delta_\alpha \\ &= -0.00930 + 0.01601 + 0.00260 \\ &= 0.00931 \text{ amu} = 8.67 \text{ MeV} \end{aligned}$$

(c) This energy is

[B.E. of O^{16} + 4 (B.E. of α particles)]

$$\begin{aligned} &= -\Delta_{O^{16}} + 4 \Delta_\alpha \\ &= 4 \times 0.00260 + 0.00509 \\ &= 0.01549 \text{ amu} = 14.42 \text{ MeV} \end{aligned}$$

$$\begin{aligned}
 6.257 \quad & \text{B.E. of a neutron in } B^{11} - \text{B.E. of a proton in } B^{11} \\
 & = (\Delta_n - \Delta_{B^{11}} + \Delta_{B^{10}}) - (\Delta_p - \Delta_{B^{11}} + \Delta_{B^{10}}) \\
 & = \Delta_n - \Delta_p + \Delta_{B^{10}} - \Delta_{B^{10}} = 0.00867 - 0.00783 \\
 & + 0.01294 - 0.01354 = 0.00024 \text{ amu} = 0.223 \text{ MeV}
 \end{aligned}$$

The difference in binding energy is essentially due to the coulomb repulsion between the proton and the residual nucleus Be^{10} which together constitute B^{11} .

$$\begin{aligned}
 6.258 \quad & \text{Required energy is simply the difference in total binding energies-} \\
 & = \text{B.E. of } Ne^{20} - 2 (\text{B.E. of } He^4) - \text{B.E. of } C^{12} \\
 & = 20 \epsilon_{Ne} - 8 \epsilon_{\alpha} - 12 \epsilon_C \\
 & \quad (\epsilon \text{ is binding energy per unit nucleon.})
 \end{aligned}$$

Substitution gives 11.88 MeV .

$$\begin{aligned}
 6.259 \quad & (a) \text{ We have for } Li^8 \\
 & \quad 41.3 \text{ MeV} = 0.044361 \text{ amu} = 3 \Delta_H + 5 \Delta_n - \Delta \\
 & \text{Hence } \Delta = 3 \times 0.00783 + 5 \times 0.00867 - 0.09436 = 0.02248 \text{ amu} \\
 & (b) \text{ For } C^{10} \quad 10 \times 6.04 = 60.4 \text{ MeV} \\
 & \quad = 0.06488 \text{ amu} \\
 & \quad = 6 \Delta_H + 4 \Delta_n - \Delta \\
 & \text{Hence } \Delta = 6 \times 0.00783 + 4 \times 0.00867 - 0.06488 = 0.01678 \text{ amu} \\
 & \text{Hence the mass of } C^{10} \text{ is } 10.01678 \text{ amu}
 \end{aligned}$$

6.260 Suppose M_1, M_2, M_3, M_4 are the rest masses of the nuclei A_1, A_2, A_3 and A_4 participating in the reaction

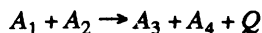

Here Q is the energy released. Then by conservation of energy.

$$Q = c^2 (M_1 + M_2 - M_3 - M_4)$$

$$\text{Now } M_1 c^2 = c^2 (Z_1 m_H + (A_1 - Z) m_n) - E_1 \text{ etc. and}$$

$$Z_1 + Z_2 = Z_3 + Z_4 \text{ (conservation of charge)}$$

$$A_1 + A_2 = A_3 + A_4 \text{ (conservation of heavy particles)}$$

$$\text{Hence } Q = (E_3 + E_4) - (E_1 + E_2)$$

6.261 (a) the energy liberated in the fission of 1 kg of U^{235} is

$$\frac{1000}{235} \times 6.023 \times 10^{23} \times 200 \text{ MeV} = 8.21 \times 10^{10} \text{ kJ}$$

The mass of coal with equivalent calorific value is

$$\frac{8.21 \times 10^{10}}{30000} \text{ kg} = 2.74 \times 10^6 \text{ kg}$$

(b) The required mass 'is

$$\frac{30 \times 10^9 \times 4.1 \times 10^3}{200 \times 1.602 \times 10^{-13} \times 6.023 \times 10^{23}} \times \frac{235}{1000} \text{ kg} = 1.49 \text{ kg}$$

6.262 The reaction is (in effect).

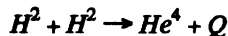

Then

$$\begin{aligned} Q &= 2 \Delta_H^2 - \Delta_{He^4} + Q \\ &= 0.02820 - 0.00260 \\ &= 0.02560 \text{ amu} = 23.8 \text{ MeV} \end{aligned}$$

Hence the energy released in 1 gm of He^4 is

$$\frac{6.023 \times 10^{23}}{4} \times 23.8 \times 1.602 \times 10^{-13} \text{ Joule} = 5.75 \times 10^8 \text{ kJ}$$

This energy can be derived from

$$\frac{5.75 \times 10^8}{30000} \text{ kg} = 1.9 \times 10^4 \text{ kg of Coal.}$$

6.263 The energy released in the reaction

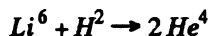

is

$$\begin{aligned} &\Delta_{Li^6} + \Delta_{H^2} - 2 \Delta_{He^4} \\ &= 0.01513 + 0.01410 - 2 \times 0.00260 \text{ amu} \\ &= 0.02403 \text{ amu} = 22.37 \text{ MeV} \end{aligned}$$

(This result for change in B.E. is correct because the contribution of Δ_n & Δ_H cancels out by conservation law for protons & neutrons.)

Energy per nucleon is then

$$\frac{22.37}{8} = 2.796 \text{ MeV/nucleon.}$$

This should be compared with the value $\frac{200}{235} = 0.85 \text{ MeV/nucleon}$

6.264 The energy of reaction

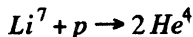

is,

$$\begin{aligned} &2 \times \text{B.E. of } He^4 - \text{B.E. of } Li^7 \\ &= 8 \epsilon_\alpha - 7 \epsilon_{Li} = 8 \times 7.06 - 7 \times 5.60 = 17.3 \text{ MeV} \end{aligned}$$

6.265 The reaction is $N^{14}(\alpha, p)O^{17}$.

It is given that (in the Lab frame where N^{14} is at rest) $T_\alpha = 4.0 \text{ MeV}$.

The momentum of incident α particle is

$$\sqrt{2 m_\alpha T_\alpha} \hat{i} = \sqrt{2 \eta_\alpha m_0 T_\alpha} \hat{i}$$

The momentum of outgoing proton is

$$\begin{aligned} & \sqrt{2 m_p T_p} (\cos \theta \hat{i} + \sin \theta \hat{j}) \\ & = \sqrt{2 \eta_p m_0 T_p} (\cos \theta \hat{i} + \sin \theta \hat{j}) \end{aligned}$$

where $\eta_p = \frac{m_p}{m_0}$, $\eta_\alpha = \frac{m_\alpha}{m_0}$,

and m_0 is the mass of O^{17} .

The momentum of O^{17} is

$$\begin{aligned} & (\sqrt{2 \eta_\alpha m_0 T_\alpha} - \sqrt{2 \eta_p m_0 T_p} \cos \theta) \hat{i} \\ & - \sqrt{2 m_0 \eta_p T_p} \sin \theta \hat{j} \end{aligned}$$

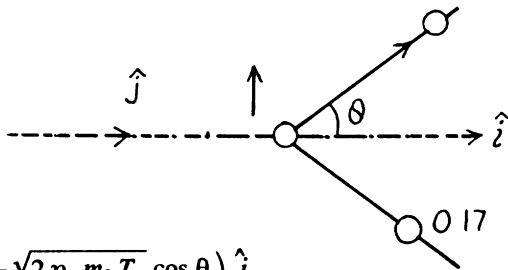

By energy conservation (conservation of energy including rest mass energy and kinetic energy)

$$\begin{aligned} & M_{14} c^2 + M_\alpha c^2 + T_\alpha \\ & = M_p c^2 + T_p + M_{17} c^2 \end{aligned}$$

$$+ \left[\left(\sqrt{\eta_\alpha T_\alpha} - \sqrt{\eta_p T_p} \cos \theta \right)^2 + \eta_p T_p \sin^2 \theta + \eta_p T_p \sin^2 \theta \right]$$

Hence by definition of the Q of reaction

$$\begin{aligned} Q & = M_{14} c^2 + M_\alpha c^2 - M_p c^2 - M_{17} c^2 \\ & = T_p + \eta_\alpha T_\alpha + \eta_p T_p - 2 \sqrt{\eta_p \eta_\alpha T_\alpha T_p} \times \cos \theta - T_\alpha \\ & = (1 + \eta_p) T_p + T_\alpha (1 - \eta_\alpha) \\ & \quad - 2 \sqrt{\eta_p \eta_\alpha T_\alpha T_p} \cos \theta = -1.19 \text{ MeV} \end{aligned}$$

6.266 (a) The reaction is $Li^7(p, n)Be^7$ and the energy of reaction is

$$\begin{aligned} Q & = (M_{Be^7} + M_{Li^7}) c^2 + (M_p - M_n) c^2 \\ & = (\Delta_{Li^7} - \Delta_{Be^7}) c^2 + \Delta_p - \Delta_n \\ & = [0.01601 + 0.00783 - 0.01693 - 0.00867] \text{ amu} \times c^2 \\ & = -1.64 \text{ MeV} \end{aligned}$$

(b) The reaction is $Be^9(n, \gamma)Be^{10}$.

Mass of γ is taken zero. Then

$$\begin{aligned} Q & = (M_{Be^9} + M_n - M_{Be^{10}}) c^2 \\ & = (\Delta_{Be^9} + \Delta_n - \Delta_{Be^{10}}) c^2 \\ & = (0.01219 + 0.00867 - 0.01354) \text{ amu} \times c^2 \\ & = 6.81 \text{ MeV} \end{aligned}$$

(c) The reaction is $Li^7(\alpha, n)B^{10}$. The energy is

$$\begin{aligned} Q &= (\Delta_{Li^7} + \Delta_\alpha - \Delta_n - \Delta_{B^{10}}) c^2 \\ &= (0.01601 + 0.00260 - 0.00867 - 0.01294) \text{ amu} \times c^2 \\ &= -2.79 \text{ MeV} \end{aligned}$$

(d) The reaction is $O^{16}(d, \alpha)N^{14}$. The energy of reaction is

$$\begin{aligned} Q &= (\Delta_{O^{16}} + \Delta_d - \Delta_\alpha - \Delta_{N^{14}}) c^2 \\ &= (-0.00509 + 0.01410 - 0.00260 - 0.00307) \text{ amu} \times c^2 \\ &= 3.11 \text{ MeV} \end{aligned}$$

6.267 The reaction is $B^{10}(n, \alpha)Li^7$. The energy of the reaction is

$$\begin{aligned} Q &= (\Delta_{B^{10}} + \Delta_n - \Delta_\alpha - \Delta_{Li^7}) c^2 \\ &= (0.01294 + 0.00867 - 0.00260 - 0.01601) \text{ amu} \times c^2 \\ &= 2.79 \text{ MeV} \end{aligned}$$

Since the incident neutron is very slow and B^{10} is stationary, the final total momentum must also be zero. So the reaction products must emerge in opposite directions. If their speeds are, respectively, v_α and v_{Li}

then

$$4 v_\alpha = 7 v_{Li}$$

and

$$\frac{1}{2} (4 v_\alpha^2 + 7 v_{Li}^2) \times 1.672 \times 10^{-24} = 2.79 \times 1.602 \times 10^{-6}$$

So

$$\frac{1}{2} \times 4 v_\alpha^2 \left(1 + \frac{4}{7}\right) = 2.70 \times 10^{18} \text{ cm}^2/\text{s}^2$$

or

$$v_\alpha = 9.27 \times 10^6 \text{ m/s}$$

Then

$$v_{Li} = 5.3 \times 10^6 \text{ m/s}$$

6.268 Q of this reaction ($Li^7(p, n)Be^7$) was calculated in problem 266 (a). If it is -1.64 MeV.

We have by conservation of momentum and energy $p_p = p_{Be}$ (since initial Li and final neutron are both at rest)

$$\frac{p_p^2}{2 m_p} = \frac{p_{Be}^2}{2 m_{Li}} + 1.64$$

Then

$$\frac{p_p^2}{2 m_p} \left(1 - \frac{m_p}{m_{Be}}\right) = 1.64$$

Hence

$$T_p = \frac{p_p^2}{2 m_p} = \frac{7}{6} \times 1.64 \text{ MeV} = 1.91 \text{ MeV}$$

6.269 It is understood that Be^9 is initially at rest. The moment of the outgoing neutron is $\sqrt{2 m_n T_n} \hat{j}$. The momentum of C^{12} is

$$\sqrt{2m_\alpha T} \hat{i} - \sqrt{2m_n T_n} \hat{j}$$

Then by energy conservation

$$T + Q = T_n + \frac{2m_\alpha T + 2m_n T_n}{2m_{ci}}$$

(m_c is the mass of C^{12})

$$\text{Thus } T_n = \frac{m_c(T + Q) - m_\alpha T}{m_c + m_n}$$

$$= \frac{(m_c - m_\alpha)T + m_c Q}{m_c + m_n} = \frac{Q + \left(1 - \frac{m_\alpha}{m_c}\right)T}{1 + \frac{m_n}{m_c}} = 8.52 \text{ MeV}$$

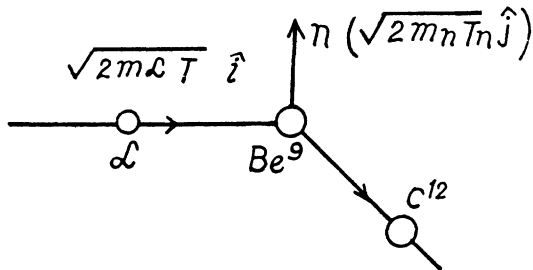

6.270 The Q value of the reaction $Li^7(p, \alpha)He^4$ is

$$\begin{aligned} Q &= (\Delta_{Li^7} + \Delta_H - 2\Delta_{He^4})c^2 \\ &= (0.01601 + 0.00783 - 0.00520) \text{ amu} \times c^2 \\ &= 0.01864 \text{ amu} \times c^2 = 17.35 \text{ MeV} \end{aligned}$$

Since the direction of He^4 nuclei is symmetrical, their momenta must also be equal. Let T be the K.E. of each He^4 . Then

$$p_p = 2\sqrt{2m_{He}T} \cos \frac{\theta}{2}$$

(p_p is the momentum of proton). Also

$$\frac{p_p^2}{2m_p} + Q = 2T = T_p + Q$$

$$\begin{aligned} \text{Hence } T_p + Q &= 2 \frac{p_p^2 \sec^2 \frac{\theta}{2}}{8m_{He}} \\ &= T_p \frac{m_p}{2m_{He}} \sec^2 \frac{\theta}{2} \end{aligned}$$

$$\text{Hence } \cos \frac{\theta}{2} = \sqrt{\frac{m_p}{2m_{He}} \frac{T_p}{T_p + Q}}$$

Substitution gives

$$\theta = 170.53^\circ$$

$$\text{Also } T = \frac{1}{2}(T_p + Q) = 9.18 \text{ MeV.}$$

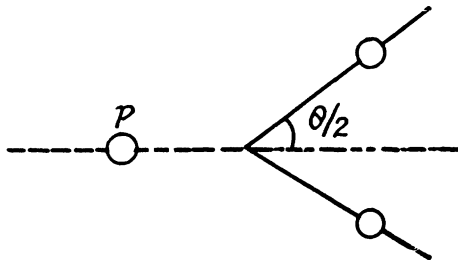

6.271 Energy required is minimum when the reaction products all move in the direction of the incident particle with the same velocity (so that the combination is at rest in the centre of mass frame). We then have

$$\sqrt{2mT_{th}} = (m+M)v$$

(Total mass is constant in the nonrelativistic limit).

$$T_{th} - |Q| = \frac{1}{2}(m+M)v^2 = \frac{mT_{th}}{m+M}$$

or
$$T_{th} \frac{M}{m+M} = |Q|$$

Hence
$$T_{th} = \left(1 + \frac{m}{M}\right) |Q|$$

6.272 The result of the previous problem applies and we find that energy required to split a deuteron is

$$T \geq \left(1 + \frac{M_p}{M_d}\right) E_b = 3.3 \text{ MeV}$$

6.273 Since the reaction $Li^7(p, n)Be^7$ ($Q = -1.65 \text{ MeV}$) is initiated, the incident proton energy must be

$$\geq \left(1 + \frac{M_p}{M_{Li}}\right) \times 1.65 = 1.89 \text{ MeV}$$

since the reaction $Be^9(p, n)B^9$ ($Q = -1.85 \text{ MeV}$) is not initiated,

$$T \leq \left(1 + \frac{M_p}{M_{Be}}\right) \times 1.85 = 2.06 \text{ MeV} \quad \text{Thus} \quad 1.89 \text{ MeV} \leq T_p \leq 2.06 \text{ MeV}$$

6.274 We have $4.0 = \left(1 + \frac{m_n}{M_{B^{11}}}\right) |Q|$

or
$$Q = -\frac{11}{12} \times 4 \text{ MeV} = -3.67 \text{ MeV}$$

6.275 The Q of the reaction $Li^7(p, n)Be^7$ was calculated in problem 266 (a). It is -1.64 MeV . Hence, the threshold K.E. of protons for initiating this reaction is

$$T_{th} = \left(1 + \frac{m_p}{m_{Li}}\right) |Q| = \frac{8}{7} \times 1.64 = 1.87 \text{ MeV}$$

For the reaction $Li^7(p, d)Li^6$

we find
$$\begin{aligned} Q &= (\Delta_{Li^7} + \Delta_M - \Delta_d - \Delta_{Li^6}) c^2 \\ &= (0.01601 + 0.00783 - 0.01410 - 0.01513) \text{ amu} \times c^2 \\ &= -5.02 \text{ MeV} \end{aligned}$$

The threshold proton energy for initiating this reaction is

$$T_{th} = \left(1 + \frac{m_p}{m_{Li^7}}\right) \times |Q| = 5.73 \text{ MeV}$$

- 6.276 The Q of $Li^7(\alpha, n)B^{10}$ was calculated in problem 266 (c). It is $Q = 2.79$ MeV. Then the threshold energy of α -particle is

$$T_{th} = \left(1 + \frac{m_\alpha}{m_{Li}}\right) |Q| = \left(1 + \frac{4}{7}\right) 2.79 = 4.38 \text{ MeV}$$

The velocity of B^{10} in this case is simply the velocity of centre of mass :-

$$v = \frac{\sqrt{2 m_\alpha T_{th}}}{m_\alpha + m_{Li}} = \frac{1}{1 + \frac{m_{Li}}{m_\alpha}} \sqrt{\frac{2 T_{th}}{m_\alpha}}$$

This is because both B^{10} and n are at rest in the CM frame at threshold.

Substituting the values of various quantities

we get

$$v = 5.27 \times 10^6 \text{ m/s}$$

- 6.277 The momentum of incident neutron is $\sqrt{2 m_n T} \hat{i}$, that of α particle is $\sqrt{2 m_\alpha T_\alpha} \hat{j}$ and of Be^9 is

$$-\sqrt{2 m_\alpha T_\alpha} \hat{j} + \sqrt{2 m_n T} \hat{i}$$

By conservation of energy

$$T = T_\alpha + \frac{m_\alpha T_\alpha + m_n T}{M} + |Q|$$

(M is the mass of Be^9). Thus

$$T_\alpha = \left[T \left(1 - \frac{m_n}{M}\right) - |Q| \right] \frac{M}{M + m_\alpha}$$

Using

$$T_{th} = \left(1 + \frac{m_n}{M}\right) |Q|$$

we get

$$T_\alpha = \frac{M}{M + m_\alpha} \left[\left(1 - \frac{m_n}{M}\right) T - \frac{T_{th}}{1 + \frac{m_n}{M}} \right]$$

M' is the mass of C^{12} nucleus.

$$\text{or } T_\alpha = \frac{1}{M + m_\alpha} \left[(M - m_n) T - \frac{M M'}{M' + m_n} T_{th} \right] = 2.21 \text{ MeV}$$

- 6.278 The formula of problem 6.271 does not apply here because the photon is always relativistic.

At threshold, the energy of the photon E_γ implies a momentum $\frac{E_\gamma}{c}$. The velocity of centre of mass with respect to the rest frame of initial H^2 is

$$\frac{E_\gamma}{(m_n + m_p) c}$$

Since both n & p are at rest in CM frame at threshold, we write

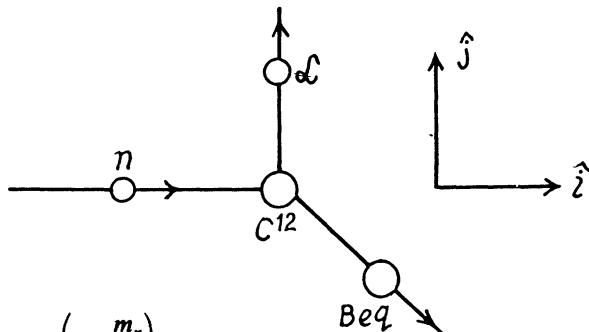

$$E_{\gamma} = \frac{E_b^2}{2(m_n + m_p)c^2} + E_b$$

by conservation of energy. Since the first term is a small correction, we have

$$E_{\gamma} \approx E_b + \frac{E_b^2}{2(m_n + m_p)c^2}$$

Thus

$$\frac{\delta E}{E_b} = \frac{E_b}{2(m_n + m_p)c^2} = \frac{2 \cdot 2}{2 \times 2 \times 938} = 5.9 \times 10^{-4}$$

or nearly 0.06 %.

6.279 The reaction is

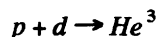

Excitation energy of He^3 is just the energy available in centre of mass. The velocity of the centre of mass is

$$\frac{\sqrt{2 m_p T_p}}{m_p + m_d} = \frac{1}{3} \sqrt{\frac{2 T_p}{m_p}}$$

In the CM frame, the kinetic energy available is ($m_d = 2 m_p$)

$$\frac{1}{2} m_p \left(\frac{2}{3} \sqrt{\frac{2 T_p}{m_p}} \right)^2 + \frac{1}{2} 2 m_p \left(\frac{1}{3} \sqrt{\frac{2 T_p}{m_p}} \right)^2 = \frac{2 T_p}{3}$$

The total energy available is then $Q + \frac{2 T_p}{3}$

where

$$\begin{aligned} Q &= c^2 (\Delta_n + \Delta_d - \Delta_{He^3}) \\ &= c^2 \times (0.00783 + 0.01410 - 0.01603) \text{ amu} \\ &= 5.49 \text{ MeV} \end{aligned}$$

Finally

$$E = 6.49 \text{ MeV}.$$

6.280 The reaction is

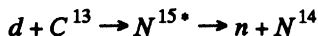

Maxima of yields determine the energy levels of N^{15*} . As in the previous problem the excitation energy is

$$E_{exc} = Q + E_K$$

where E_K = available kinetic energy. This is found as in the previous problem. The velocity of the centre of mass is

$$\frac{\sqrt{2 m_d T_i}}{m_d + m_c} = \frac{m_d}{m_d + m_c} \sqrt{\frac{2 T_i}{m_d}}$$

$$\text{So } E_K = \frac{1}{2} m_d \left(1 - \frac{m_d}{m_d + m_c} \right)^2 \frac{2 T_i}{m_d} + \frac{1}{2} m_c \left(\frac{m_d}{m_d + m_c} \right)^2 \frac{2 T_i}{m_d} = \frac{m_c}{m_d + m_c} T_i$$

Q is the Q value for the ground state of N^{15} : We have

$$\begin{aligned} Q &= c^2 \times (\Delta_d + \Delta_c^{13} - \Delta_N^{15}) \\ &= c^2 \times (0.01410 + 0.00335 - 0.00011) \text{ amu} \\ &= 16.14 \text{ MeV} \end{aligned}$$

The excitation energies then are

$$\begin{aligned} &16.66 \text{ MeV}, 16.92 \text{ MeV} \\ &17.49 \text{ MeV and } 17.70 \text{ MeV.} \end{aligned}$$

6.281 We have the relation

$$\frac{1}{\eta} = e^{-n\sigma d}$$

Here $\frac{1}{\eta}$ = attenuation factor

n = no. of Cd nuclei per unit volume

σ = effective cross section

d = thickness of the plate

$$\text{Now } n = \frac{\rho N_A}{M}$$

(ρ = density, M = Molar weight of Cd, N_A = Avogadro number.)

$$\text{Thus } \sigma = \frac{M}{\rho N_A d} \ln \eta = 2.53 \text{ kb}$$

6.282 Here

$$\frac{1}{\eta} = e^{-(n_2 \sigma_2 + n_1 \sigma_1) d}$$

where 1 refers to O^1 and 2 to D nuclei

Using $n_2 = 2n$, $n_1 = n$ = concentration of O nuclei in heavy water we get

$$\frac{1}{\eta} = e^{-(2\sigma_2 + \sigma_1) n d}$$

Now using the data for heavy water

$$n = \frac{1.1 \times 6.023 \times 10^{23}}{20} = 3.313 \times 10^{22} \text{ per cc}$$

Thus substituting the values

$$\eta = 20.4 = \frac{I_0}{I}$$

6.283 In traversing a distance d the fraction which is either scattered or absorbed is clearly

$$1 - e^{-n(\sigma_s + \sigma_a)d}$$

by the usual definition of the attenuation factor. Of this, the fraction scattered is (by definition of scattering and absorption cross section)

$$w = \left[1 - e^{-n(\sigma_s + \sigma_a)d} \right] \frac{\sigma_s}{\sigma_s + \sigma_a}$$

In iron
$$n = \frac{\rho \times N_A}{M} = 8.39 \times 10^{22} \text{ per cc}$$

Substitution gives
$$w = 0.352$$

6.284 (a) Assuming of course, that each reaction produces a radio nuclide of the same type, the decay constant α of the radionuclide is k/w . Hence $T = \frac{\ln 2}{\lambda} = \frac{w}{k} \ln 2$

(b) number of bombarding particles is : $\frac{It}{e}$

(e = charge on proton). Then the number of Be^7 produced is : $\frac{It}{e} w$

If λ = decay constant of $Be^7 = \frac{\ln 2}{T}$, then the activity is $A = \frac{It}{e} w \cdot \frac{\ln 2}{T}$

Hence
$$w = \frac{eAT}{It \ln 2} = 1.98 \times 10^{-3}$$

6.285 (a) Suppose N_0 = no. of Au^{197} nuclei in the foil. Then the number of Au^{197} nuclei transformed in time t is

$$N_0 \cdot J \cdot \sigma \cdot t$$

For this to equal ηN_0 , we must have

$$t = \eta / (J \cdot \sigma) = 323 \text{ years}$$

(b) Rate of formation of the Au^{198} nuclei is $N_0 \cdot J \cdot \sigma$ per sec and rate of decay is λn , where n is the number of Au^{198} at any instant.

Thus
$$\frac{dn}{dt} = n_0 \cdot J \cdot \sigma - \lambda n$$

The maximum number of Au^{198} is clearly

$$n_{\max} = \frac{N_0 \cdot J \cdot \sigma}{\lambda} = \frac{N_0 \cdot J \cdot \sigma \cdot T}{\ln 2}$$

because if n is smaller, $\frac{dn}{dt} > 0$ and n will increase further and if n is larger

$\frac{dn}{dt} < 0$ and n will decrease. (Actually n_{\max} is approached steadily as $t \rightarrow \infty$)

Substitution gives using $N_0 = 3.057 \times 10^{19}$, $n_{\max} = 1.01 \times 10^{13}$

6.286 Rate of formation of the radionuclide is $nJ\sigma$ per unit area per-sec. Rate of decay is λN . Thus

$$\frac{dN}{dt} = nJ\sigma - \lambda N \text{ per unit area per second}$$

Then
$$\left(\frac{dN}{dt} + \lambda N\right) e^{\lambda t} = nJ\sigma e^{\lambda t} \quad \text{or} \quad \frac{d}{dt}(N e^{\lambda t}) = nJ\sigma e^{\lambda t}$$

Hence
$$N e^{\lambda t} = \text{Const} + \frac{nJ\sigma}{\lambda} e^{\lambda t}$$

The number of radionuclide at $t = 0$ when the process starts is zero. So constant = $-\frac{nJ\sigma}{\lambda}$

Then
$$N = \frac{nJ\sigma}{\lambda} (1 - e^{-\lambda t})$$

6.287 We apply the formula of the previous problem except that have N = no. of radio nuclide and no. of host nuclei originally.

Here
$$n = \frac{0.2}{197} \times 6.023 \times 10^{23} = 6.115 \times 10^{20}$$

Then after time t
$$N = \frac{nJ\sigma T}{\ln 2} \left(1 - e^{-\frac{t \ln 2}{T}}\right)$$

T = half life of the radionuclide.

After the source of neutrons is cut off the activity after time T will be

$$A = \frac{nJ\sigma T}{\ln 2} (1 - e^{-t \ln 2/T}) e^{-\tau \ln 2/T \times \frac{\ln 2}{T}} = nJ\sigma (1 - e^{-t \ln 2/T}) e^{-\tau \ln 2/T}$$

Thus
$$J = A e^{\tau \ln 2/T} / n\sigma (1 - e^{-t \ln 2/T}) = 5.92 \times 10^9 \text{ part/cm}^2 \cdot \text{s}$$

6.288 No. of nuclei in the first generation = No. of nuclei initially = N_0

N_0 in the second generation = $N_0 \times$ multiplication factor = $N_0 \cdot k$

N_0 in the the 3rd generation = $N_0 \cdot k \cdot k = N_0 k^2$

N_0 in the nth generation = $N_0 k^{n-1}$

Substitution gives 1.25×10^5 neutrons

6.289 N_0 of fissions per unit time is clearly P/E . Hence no. of neutrons produced per unit time to $\frac{\nu P}{E}$. Substitution gives 7.80×10^{18} neutrons/sec

6.290 (a) This number is k^{n-1} where n = no. of generations in time $t = t/T$
Substitution gives 388.

(b) We write
$$k^{n-1} = e^{\left(\frac{T}{\tau} - 1\right) \ln k} = e$$

or
$$\frac{T}{\tau} - 1 = \frac{1}{\ln k} \quad \text{and} \quad T = \tau \left(1 + \frac{1}{\ln k}\right) = 10.15 \text{ sec}$$

6.7 ELEMENTARY PARTICLES

6.291 The formula is

$$T = \sqrt{c^2 p^2 + m_0^2 c^4} - m_0 c^2$$

Thus $T = 5.3 \text{ MeV}$ for $p = 0.10 \frac{\text{GeV}}{c} = 5.3 \times 10^{-3} \text{ GeV}$

$$T = 0.433 \text{ GeV} \quad \text{for } p = 1.0 \frac{\text{GeV}}{c}$$

$$T = 9.106 \text{ GeV} \quad \text{for } p = 10 \frac{\text{GeV}}{c}$$

Here we have used $m_0 c^2 = 0.938 \text{ GeV}$

6.292 Energy of pions is $(1 + \eta) m_0 c^2$ so

$$(1 + \eta) m_0 c^2 = \frac{m_0 c^2}{\sqrt{1 - \beta^2}}$$

Hence $\frac{1}{\sqrt{1 - \beta^2}} = 1 + \eta$ or $\beta = \frac{\sqrt{\eta(2 + \eta)}}{1 + \eta}$

Here $\beta = \frac{v}{c}$ of pion. Hence time dilation factor is $1 + \eta$ and the distance traversed by the pion in its lifetime will be

$$\frac{c \beta \tau_0}{\sqrt{1 - \beta^2}} = c \tau_0 \sqrt{\eta(2 + \eta)} = 15.0 \text{ metres}$$

on substituting the values of various quantities. (Note. The factor $\frac{1}{\sqrt{1 - \beta^2}}$ can be looked at as a time dilation effect in the laboratory frame or as length contraction factor brought to the other side in the proper frame of the pion).

6.293 From the previous problem $l = c \tau_0 \sqrt{\eta(2 + \eta)}$

where $\eta = \frac{T}{m_\pi c^2}$, m_π is the rest mass of pions.

substitution gives

$$\begin{aligned} \tau_0 &= \frac{l}{c \sqrt{\eta(2 + \eta)}} = 2.63 \text{ ns} \\ &= \frac{l m_\pi c}{\sqrt{T(T + 2 m_\pi c^2)}} \end{aligned}$$

where we have used $\eta = \frac{100}{139.6} = 0.716$

6.294 Here $\eta = \frac{T}{m c^2} = 1$ so the life time of the pion in the laboratory frame is

$$\eta = (1 + \eta) \tau_0 = 2 \tau_0$$

The law of radioactive decay implies that the flux decrease by the factor.

$$\begin{aligned} \frac{J}{J_0} &= e^{-l/\tau} = e^{-l/v\tau} = e^{-l/c\tau_0\sqrt{\eta(2+\eta)}} \\ &= \exp\left(-\frac{m c l}{\tau_0 \sqrt{T(T+2 m c^2)}}\right) = 0.221 \end{aligned}$$

6.295 Energy-momentum conservation implies

$$O = \vec{p}_\mu + \vec{p}_\nu$$

$$m_\pi c^2 = E_\mu + E_\nu \quad \text{or} \quad m_\pi c^2 - E_\nu = E_\mu$$

But

$$E_\nu = c |\vec{p}_\nu| = c |\vec{p}_\mu|. \quad \text{Thus}$$

$$m_\pi^2 c^4 - 2 m_\pi c^2 \cdot c |\vec{p}_\mu| + c^2 p_\mu^2 = E_\mu^2 = c^2 p_\mu^2 + m_\mu^2 c^4$$

Hence

$$c |\vec{p}_\mu| = \frac{m_\pi^2 - m_\mu^2}{2 m_\pi} \cdot c^2$$

So

$$\begin{aligned} T_\mu &= \sqrt{c^2 p_\mu^2 + m_\mu^2 c^4} - m_\mu c^2 = \sqrt{\frac{(m_\pi^2 - m_\mu^2)^2}{4 m_\pi^2} + m_\mu^2 \cdot c^2} - m_\mu c^2 \\ &= \frac{m_\pi^2 + m_\mu^2}{2 m_\pi} c^2 - m_\mu c^2 = \frac{(m_\pi - m_\mu)^2}{2 m_\pi} \cdot c^2 \end{aligned}$$

Substituting

$$m_\pi c^2 = 139.6 \text{ MeV}$$

$$m_\mu c^2 = 105.7 \text{ MeV we get}$$

$$T_\mu = 4.12 \text{ MeV}$$

Also

$$E_\nu = \frac{m_\pi^2 - m_\mu^2}{2 m_\pi} c^2 = 29.8 \text{ MeV}$$

6.296 We have

$$O = \vec{p}_n + \vec{p}_\pi \tag{1}$$

$$m_\Sigma c^2 = E_n + E_\pi$$

or

$$(m_\Sigma c^2 - E_n)^2 = E_\pi^2$$

or

$$m_\Sigma^2 c^4 - 2 m_\Sigma c^2 E_n = E_\pi^2 - E_n^2 = c^4 m_\pi^2 - c^4 m_n^2$$

because (1) implies

$$E_\pi^2 - E_n^2 = m_\pi^2 c^4 - m_n^2 c^4$$

Hence

$$E_n = \frac{m_\Sigma^2 + m_n^2 - m_\pi^2}{2 m_\Sigma} c^2$$

and
$$T_n = \left(\frac{m_\Sigma^2 + m_n^2 - m_\pi^2}{2 m_\Sigma} - m_n \right) c^2 = \frac{(m_\Sigma - m_n)^2 - m_\pi^2}{2 m_\Sigma} c^2.$$

Substitution gives
$$T_n = 19.55 \text{ MeV}$$

6.297 The reaction is

$$\mu^+ \rightarrow e^+ + \bar{\nu}_e + \bar{\nu}_\mu$$

The neutrinos are massless. The positron will carry largest momentum if both neutrinos ($\bar{\nu}_e$ & $\bar{\nu}_\mu$) move in the same direction in the rest frame of the muon. Then the final product is effectively a two body system and we get from problem (295)

$$(T_{e^+})_{\max} = \frac{(m_\mu - m_e)^2}{2 m_\mu} c^2$$

Substitution gives
$$(T_{e^+})_{\max} = 52.35 \text{ MeV}$$

6.298 By conservation of energy-momentum

$$M c^2 = E_p + E_\pi$$

$$0 = \vec{p}_p + \vec{p}_\pi$$

Then

$$\begin{aligned} m_\pi^2 c^4 &= E_\pi^2 - \vec{p}_\pi^2 c^2 = (M c^2 - E_p)^2 - c^2 \vec{p}_p^2 \\ &= M^2 c^4 - 2 M c^2 E_p + m_p^2 c^4 \end{aligned}$$

This is a quadratic equation in M

$$M^2 - 2 \frac{E_p}{c^2} M + m_p^2 - m_\pi^2 = 0$$

or using $E_p = m_p c^2 + T$ and solving

$$\left(M - \frac{E_p}{c^2} \right)^2 = \frac{E_p^2}{c^4} - m_p^2 + m_\pi^2$$

Hence,

$$M = \frac{E_p}{c^2} + \sqrt{\frac{E_p^2}{c^4} - m_p^2 + m_\pi^2}$$

taking the positive sign. Thus

$$M = m_p + \frac{T}{c^2} + \sqrt{m_\pi^2 + \frac{T}{c^2} \left(2 m_p + \frac{T}{c^2} \right)}$$

Substitution gives

$$M = 1115.4 \frac{\text{MeV}}{c^2}$$

From the table of masses we identify the particle as a Λ particle

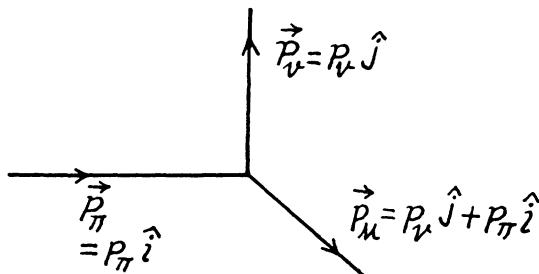

See the diagram. By conservation of energy

$$\sqrt{m_\pi^2 c^4 + c^2 p_\pi^2} = c p_\nu + \sqrt{m_\mu^2 c^4 + p_\pi^2 c^2 + c^2 p_\nu^2}$$

or

$$\left(\sqrt{m_\pi^2 c^4 + c^2 p_\pi^2} - c p_\nu \right)^2 = m_\mu^2 c^4 + c^2 p_\pi^2 + c^2 p_\nu^2$$

or

$$m_\pi^2 c^4 - 2 c p_\nu \sqrt{m_\pi^2 c^4 + c^2 p_\pi^2} = m_\mu^2 c^4$$

Hence the energy of the neutrino is

$$E_\nu = c p_\nu = \frac{m_\pi^2 c^4 - m_\mu^2 c^4}{2(m_\pi c^2 + T)}$$

on writing

$$\sqrt{m_\pi^2 c^4 + c^2 p_\pi^2} = m_\pi c^2 + T$$

Substitution gives

$$E_\nu = 21.93 \text{ MeV}$$

6.300

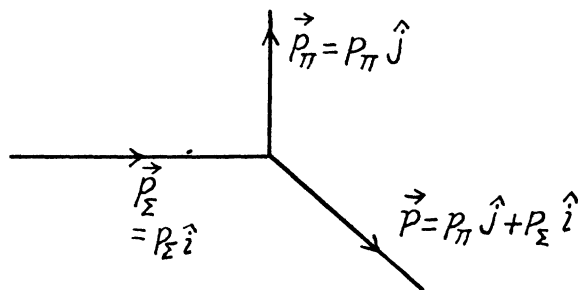

By energy conservation

$$\sqrt{m_\Sigma^2 c^4 + c^2 p_\Sigma^2} = \sqrt{m_\pi^2 c^4 + c^2 p_\pi^2} + \sqrt{m_n^2 c^4 + c^2 p_\pi^2 + c^2 p_\Sigma^2}$$

or

$$\left(\sqrt{m_\Sigma^2 c^4 + c^2 p_\Sigma^2} - \sqrt{m_\pi^2 c^4 + c^2 p_\pi^2} \right)^2 = m_n^2 c^4 + c^2 p_\pi^2 + c^2 p_\Sigma^2$$

or

$$\begin{aligned} m_\Sigma^2 c^4 + c^2 p_\Sigma^2 + m_\pi^2 c^4 + c^2 p_\pi^2 - 2 \sqrt{m_\pi^2 c^4 + c^2 p_\pi^2} \sqrt{m_n^2 c^4 + c^2 p_\pi^2 + c^2 p_\Sigma^2} \\ = m_n^2 c^4 + c^2 p_\pi^2 + c^2 p_\Sigma^2 \end{aligned}$$

or using the K.E. of Σ & π

$$m_{\pi}^2 = m_{\Sigma}^2 + m_{\pi}^2 - 2 \left(m_{\Sigma} + \frac{T_{\Sigma}}{c^2} \right) \left(m_{\pi} + \frac{T_{\pi}}{c^2} \right)$$

and

$$m_n = \sqrt{m_{\Sigma}^2 + m_{\pi}^2 - 2 \left(m_{\Sigma} + \frac{T_{\Sigma}}{c^2} \right) \left(m_{\pi} + \frac{T_{\pi}}{c^2} \right)} = 0.949 \frac{\text{GeV}}{c^2}$$

6.301 Here by conservation of momentum

$$p_{\pi} = 2 \times \frac{E_{\pi}}{2c} \times \cos \frac{\theta}{2}$$

or $c p_{\pi} = \bar{E}_{\pi} \cos \frac{\theta}{2}$

Thus $E_{\pi}^2 \cos^2 \frac{\theta}{2} = E_n^2 - m_{\pi}^2 c^4$

or

$$E_{\pi} = \frac{m_{\pi} c^2}{\sin \frac{\theta}{2}}$$

and

$$T_{\pi} = m_{\pi} c^2 \left(\operatorname{cosec} \frac{\theta}{2} - 1 \right)$$

substitution gives $T_{\pi} = m_{\pi} c^2 = 135 \text{ MeV}$ for $\theta = 60^\circ$.

Also

$$E_{\gamma} = \frac{m_{\pi} c^2 + T_{\pi}}{2} = \frac{m_{\pi} c^2}{2} \operatorname{cosec} \frac{\theta}{2}$$

$$= m_{\pi} c^2 \text{ in this case } (\theta = 60^\circ)$$

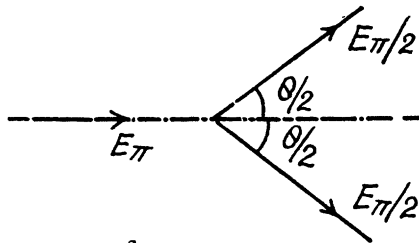

6.302 With particle masses standing for the names of the particles, the reaction is

$$m + M \rightarrow m_1 + m_2 + \dots$$

On R.H.S. let the energy momenta be $(E_1, c\vec{p}_1)$, $(E_2, c\vec{p}_2)$ etc. On the left the energy momentum of the particle m is $(E, c\vec{p})$ and that of the other particle is $(M c^2, \vec{0})$, where, ofcourse, the usual relations

$$E^2 - c^2 \vec{p}^2 = m^2 c^4 \text{ etc}$$

hold. From the conservation of energy momentum we see that

$$(E + M c^2)^2 - c^2 \vec{p}^2 = (\Sigma E_i)^2 - (\Sigma c \vec{p}_i)^2$$

Left hand side is

$$m^2 c^4 + M^2 c^4 + 2 M c^2 E$$

We evaluate the R.H.S. in the frame where $\Sigma \vec{p}_i = 0$ (CM frame of the decay product).

Then

$$R.H.S. = (\Sigma E_i)^2 \geq (\Sigma m_i c^2)^2$$

because all energies are +ve. Therefore we have the result

$$E \geq \frac{(\Sigma m_i)^2 - m^2 - M^2}{2M} c^2$$

or since $E = mc^2 + T$, we see that $T \geq T_{th}$ where

$$T_{th} = \frac{(\Sigma m_i)^2 - (m + M)^2}{2M} c^2$$

6.303 By momentum conservation

$$\sqrt{E^2 - m_e^2 c^4} = 2 \frac{E + m_e c^2}{2} \cos \frac{\theta}{2}$$

$$\text{or } \cos \frac{\theta}{2} = \frac{\sqrt{E - m_e c^2}}{E + m_e c^2} = \sqrt{\frac{T}{T + 2 m_e c^2}}$$

Substitution gives

$$\theta = 98.8^\circ$$

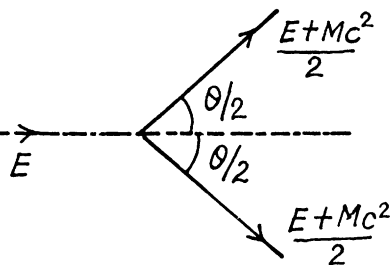

6.304 The formula of problem 3.02 gives

$$E_{th} = \frac{(\Sigma m_i)^2 - M^2}{2M} c^2$$

when the projectile is a photon

(a) For $\gamma + e^- \rightarrow e^- + e^- + e^+$

$$E_{th} = \frac{9 m_e^2 - m_e^2}{2 m_e} c^2 = 4 m_e c^2 = 2.04 \text{ MeV}$$

(b) For

$$\gamma + p \rightarrow p + \pi^+ \pi^-$$

$$E_{th} = \frac{(M_p + 2 m_\pi)^2 - M_p^2}{2 M_p} c^2 = \frac{4 m_\pi M_p + 4 m_\pi^2}{2 M_p} c^2 = 2 \left(m_\pi + \frac{m_\pi^2}{M_p} \right) c^2 = 320.8 \text{ MeV}$$

6.305 (a) For $p + p \rightarrow p + p + p + \bar{p}$

$$T \geq T_{th} = \frac{16 m_p^2 - 4 m_p^2}{2 m_p} c^2 = 6 m_p c^2 = 5.63 \text{ GeV}$$

(b) For $p + p \rightarrow p + p + \pi^0$

$$\begin{aligned} T \geq T_{th} &= \frac{(2 m_p + m_{\pi^0})^2 - 4 m_p^2}{2 m_p} c^2 \\ &= \left(2 m_\pi + \frac{m_{\pi^0}^2}{2 m_p} \right) c^2 = 0.280 \text{ GeV} \end{aligned}$$

6.306 (a) Here

$$T_{th} = \frac{(m_K + m_\Sigma)^2 - (m_\pi + m_p)^2}{2m_p} c^2$$

Substitution gives $T_{th} = 0.904 \text{ GeV}$

$$(b) T_{th} = \frac{(m_K + m_\Lambda)^2 - (m_\pi + m_p)^2}{2m_p} c^2$$

Substitution gives $T_{th} = 0.77 \text{ GeV}$.

6.307 From the Gell-Mann Nishijima formula

$$Q = I_z + \frac{Y}{2}$$

we get

$$0 = \frac{1}{2} + \frac{Y}{2} \text{ or } Y = -1$$

Also $Y = B + S \Rightarrow S = -2$. Thus the particle is Ξ^0 .

6.308 (1) The process $n \rightarrow p + e^- + \nu_e$ cannot occur as there are 2 more leptons (e^- , ν_e) on the right compared to zero on the left.

(2) The process $\pi^+ \rightarrow \mu^+ + e^- + e^+$ is forbidden because this corresponds to a change of lepton number by, (0 on the left - 1 on the right)

(3) The process $\pi^- \rightarrow \mu^- + \nu_\mu$ is forbidden because μ^- , ν_μ being both leptons $\Delta L = 2$ here.

(4), (5), (6) are allowed (except that one must distinguish between muon neutrinos and electron neutrinos). The correct names would be

$$(4) p + e^- \rightarrow n + \nu_e$$

$$(5) \mu^+ \rightarrow e^+ + \nu_e + \tilde{\nu}_\mu$$

$$(6) K^- \rightarrow \mu^- + \tilde{\nu}_\mu.$$

6.309 (1) $\pi^- + p \rightarrow \Sigma^- + K^+$

$$0 \quad 0 \quad -1 \quad 1$$

so

$$\Delta S = 0. \text{ allowed}$$

(2) $\pi^- + p \rightarrow \Sigma^+ + K^-$

$$0 \quad 0 \quad -1 \quad 1$$

so

$$\Delta S = -2. \text{ forbidden}$$

(3) $\pi^- + p \rightarrow K^- + K^+ + n$

$$0 \quad 0 \rightarrow -1 \quad 1 \quad 0$$

so

$$\Delta S = 0, \text{ allowed.}$$

$$(4) \quad n + p \rightarrow \Lambda^{\circ} + \Sigma^{+}$$

so

$$\begin{array}{cccc} 0 & 0 & -1 & -1 \\ \Delta S = -2. & \text{forbidden} \end{array}$$

$$(5) \quad \pi^{-} + n \rightarrow \mu^{-} + K^{+} + K^{-}$$

so

$$\begin{array}{cccc} 0 & 0 & \rightarrow & -2 \quad 1 \quad -1 \\ \Delta S = -2. & \text{forbidden.} \end{array}$$

$$(6) \quad K^{-} + p \rightarrow \Omega^{-} + K^{+} K^{\circ}$$

so

$$\begin{array}{cccc} -1 & 0 & -3 & +1 + 1 \\ \Delta S = 0. & \text{allowed.} \end{array}$$

$$6.310 \quad (1) \quad \Sigma^{-} \rightarrow \Lambda^{\circ} + \pi^{-}$$

is forbidden by energy conservation. The mass difference

$$M_{\Sigma^{-}} - M_{\Lambda^{\circ}} = 82 \frac{\text{MeV}}{c^2} < m_{\pi^{-}}$$

(The process $1 \rightarrow 2 + 3$ will be allowed only if $m_1 > m_2 + m_3$.)

$$(2) \quad \pi^{-} + p \rightarrow K^{+} + K^{-}$$

is disallowed by conservation of baryon number.

$$(3) \quad K^{-} + n \rightarrow \Omega^{-} + K^{+} + K^{\circ}$$

is forbidden by conservation of charge

$$(4) \quad n + p \rightarrow \Sigma^{+} + \Lambda^{\circ}$$

is forbidden by strangeness conservation.

$$(5) \quad \pi^{-} \rightarrow \mu^{-} + e^{-} + e^{+}$$

is forbidden by conservation of muon number (or lepton number).

$$(6) \quad \mu^{-} \rightarrow e^{-} + \nu_e + \tilde{\nu}_{\mu}$$

is forbidden by the separate conservation of muon number as well as lepton number.

